



Operator's manual
Manual de usuario
Manual do operador

TF545P



Please read the operator's manual carefully and make sure you understand the instructions before using the machine.

Lea detenidamente el manual de instrucciones y asegúrese de entender su contenido antes de utilizar la máquina.

Leia atentamente o manual do operador e certifique-se de que tenha entendido as instruções antes de usar a máquina.

English
Spanish
Portuguese

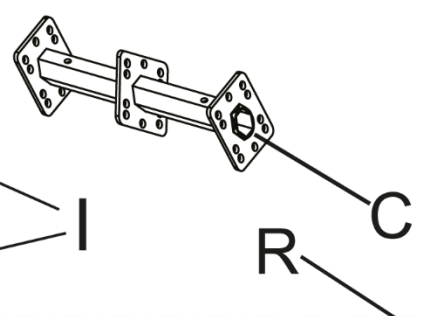
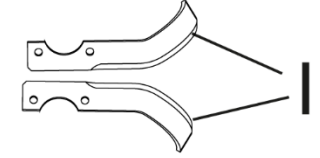
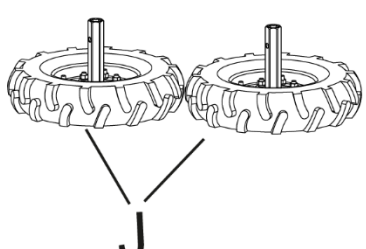
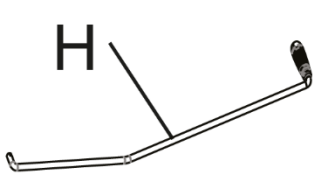
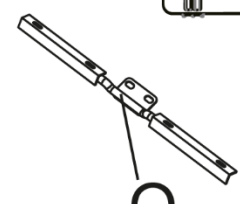
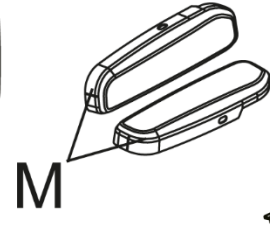
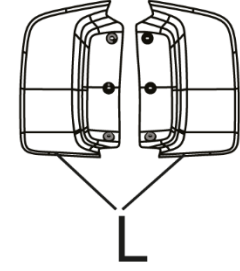
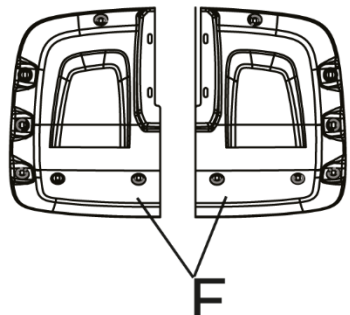
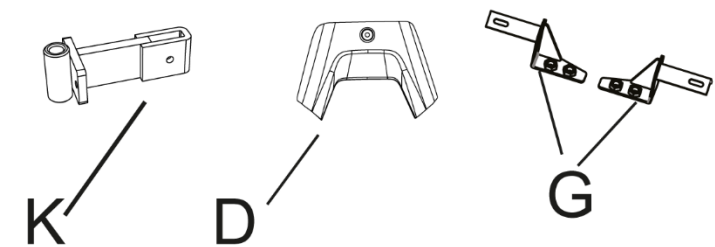
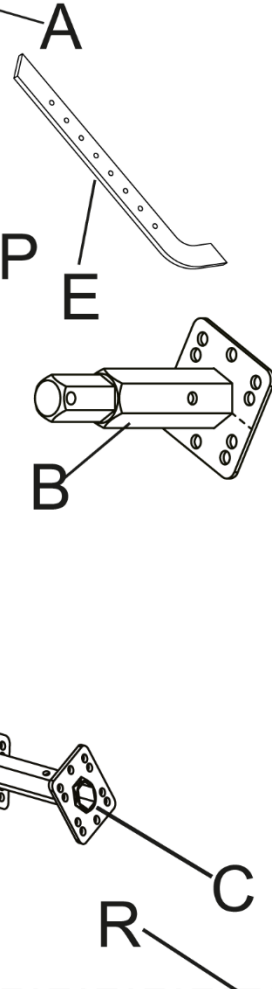
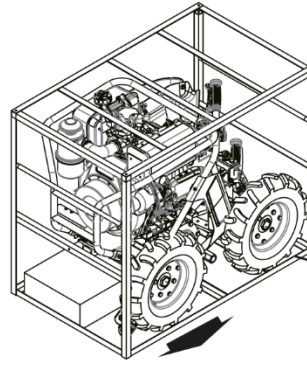
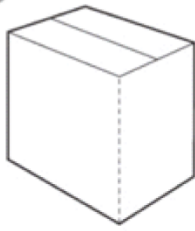

- ① X17
- ② X4
- ③ X4
- ④ X4
- ⑤ X23
- ⑥ X6
- ⑦ X2
- ⑧ X4
- ⑨ X16
- ⑩ X10
- ⑪ X2
- ⑫ X6

- For tines only
- ⑩ X2
 - ⑬ X2
 - ⑭ X2
 - ⑮ X2
 - ⑯ X32
 - ⑰ X32
 - ⑱ X32

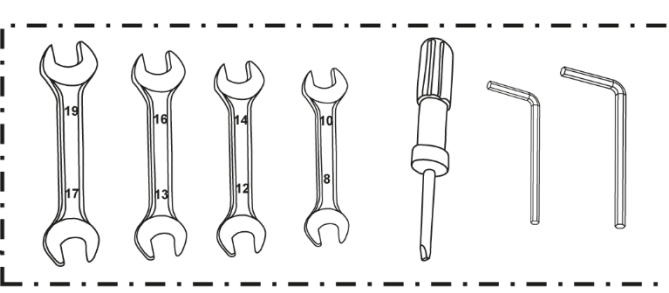

S

T

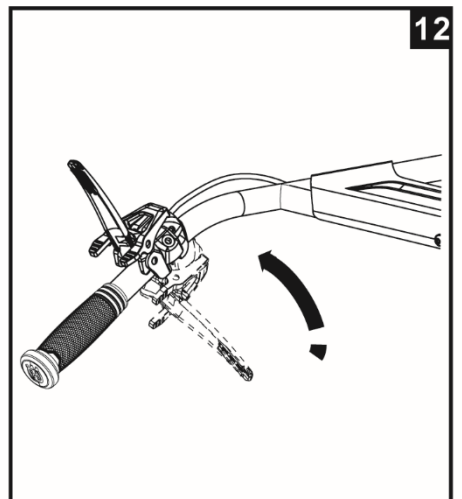
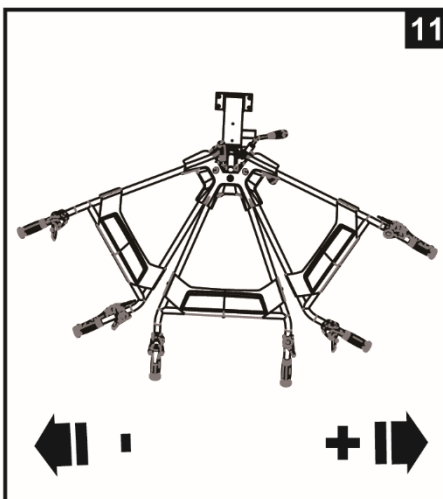
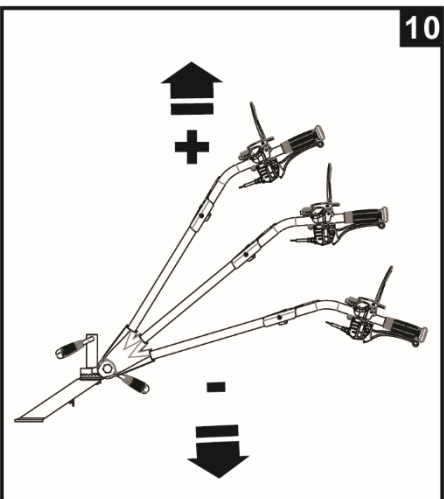
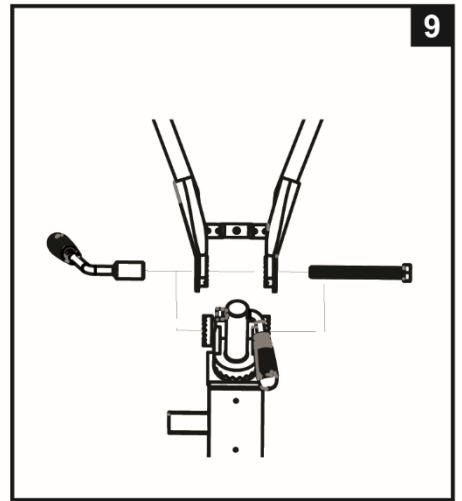
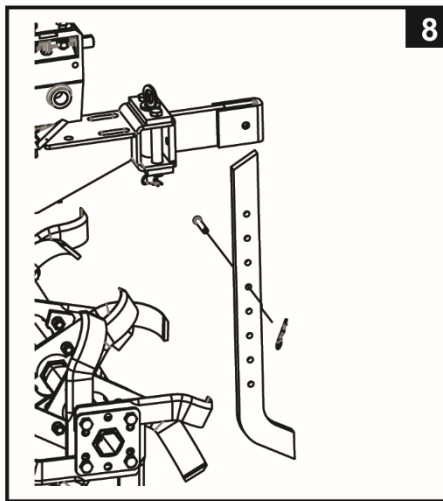
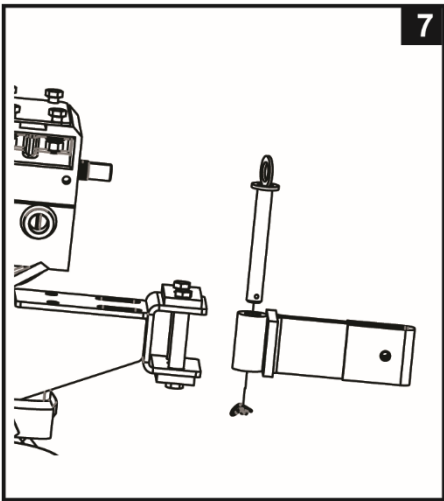
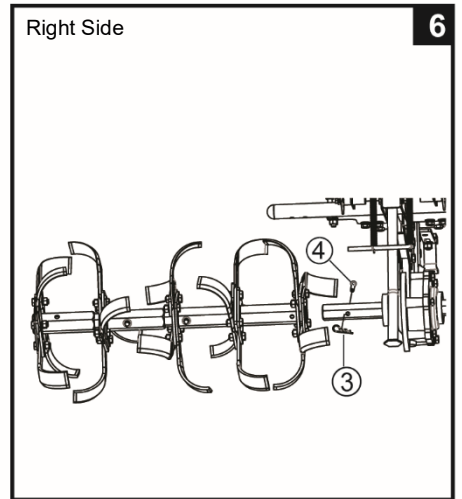
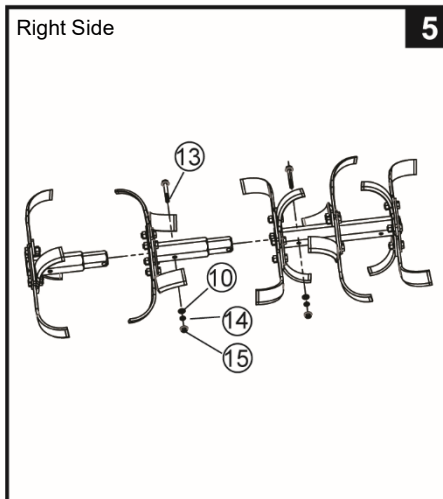
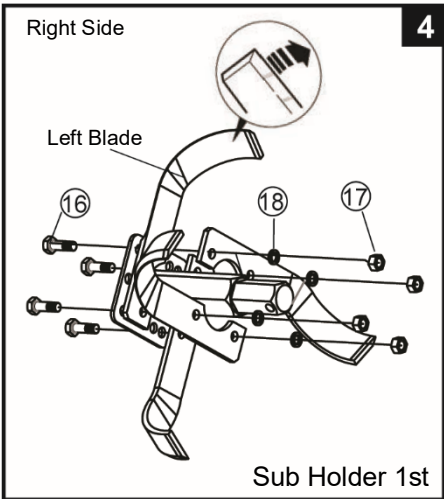
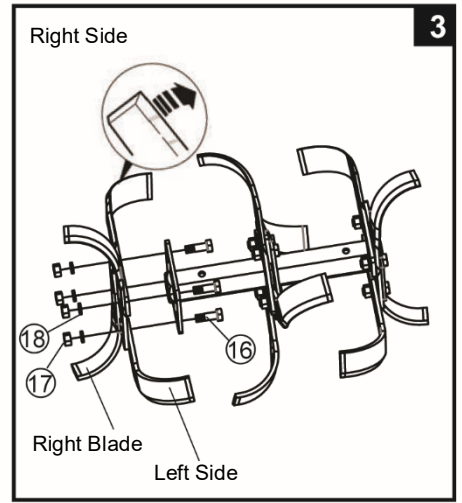
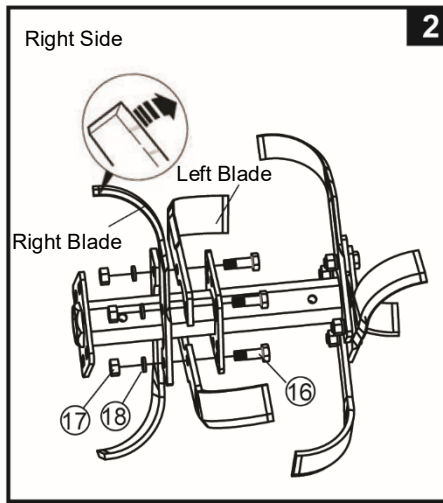
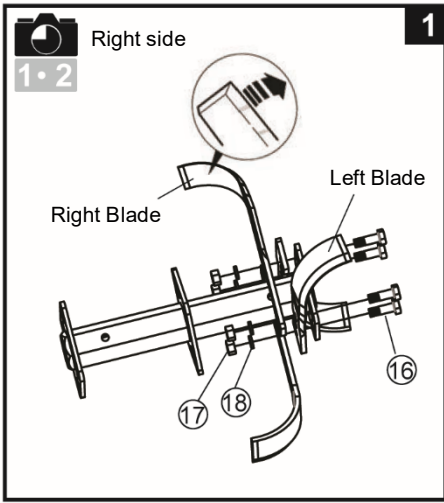

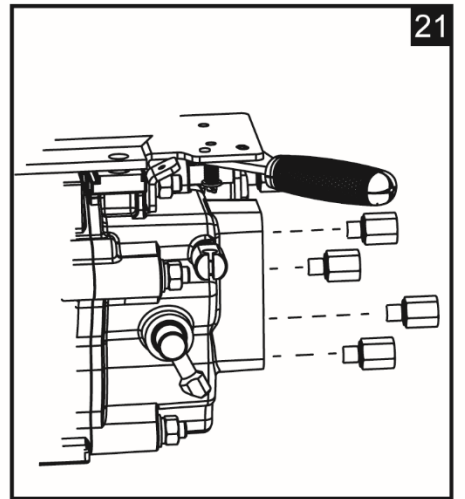
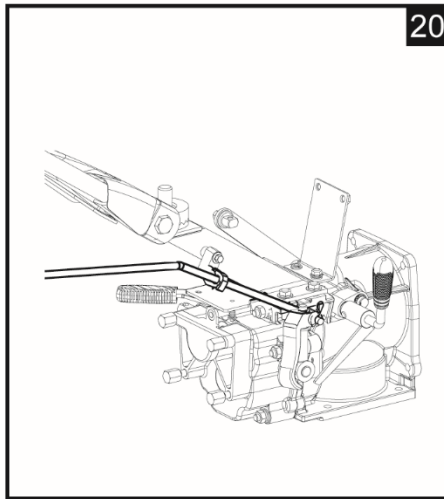
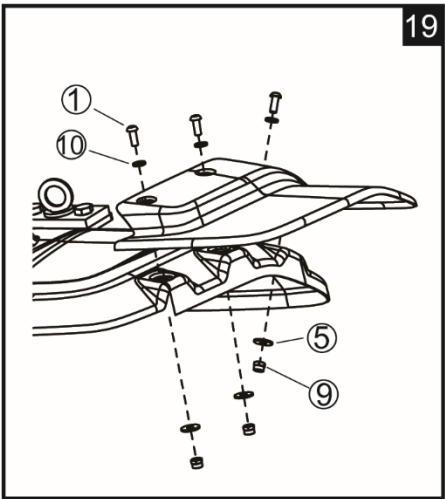
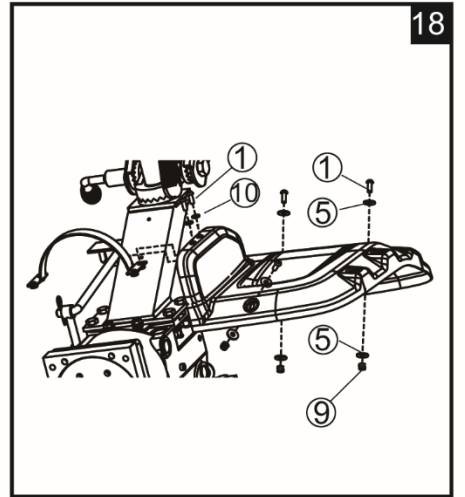
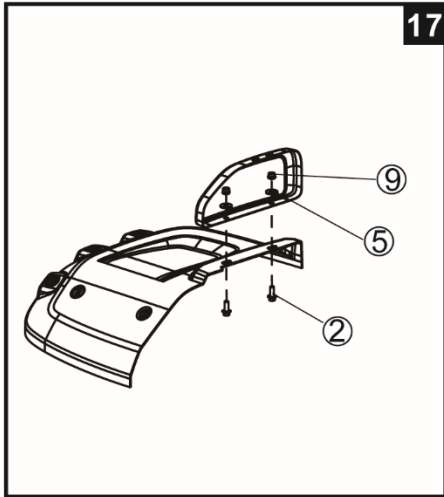
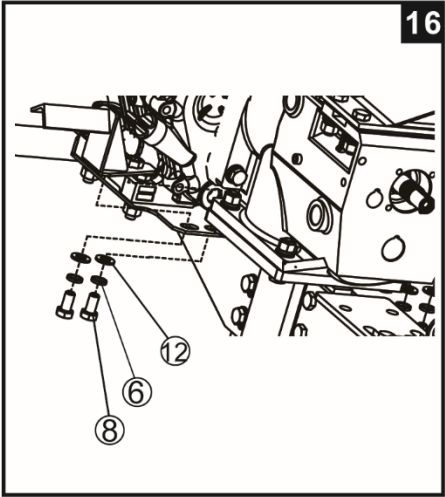
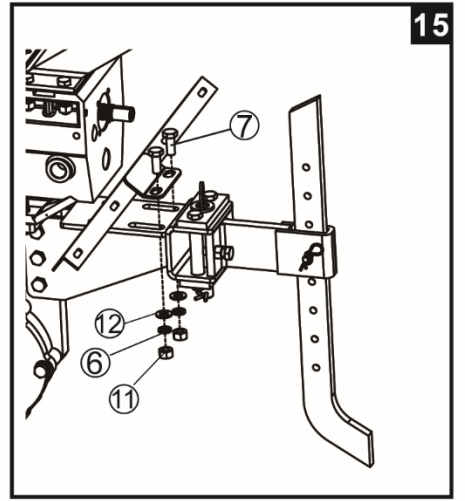
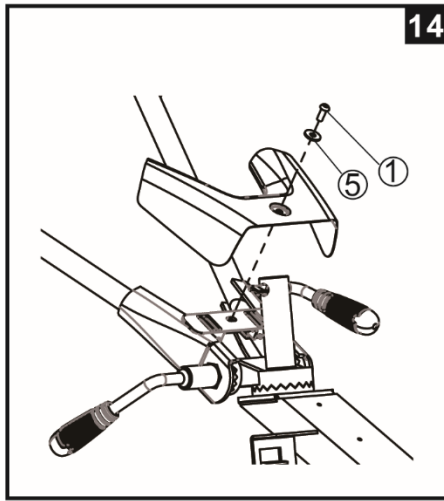
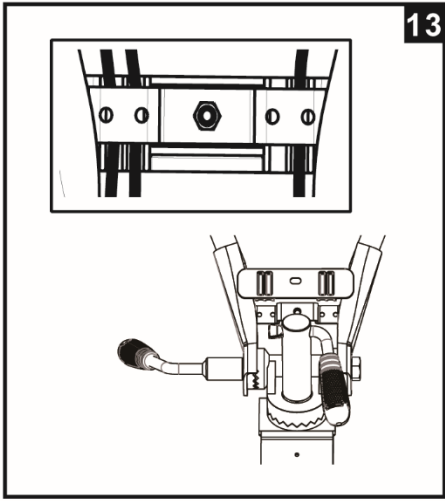

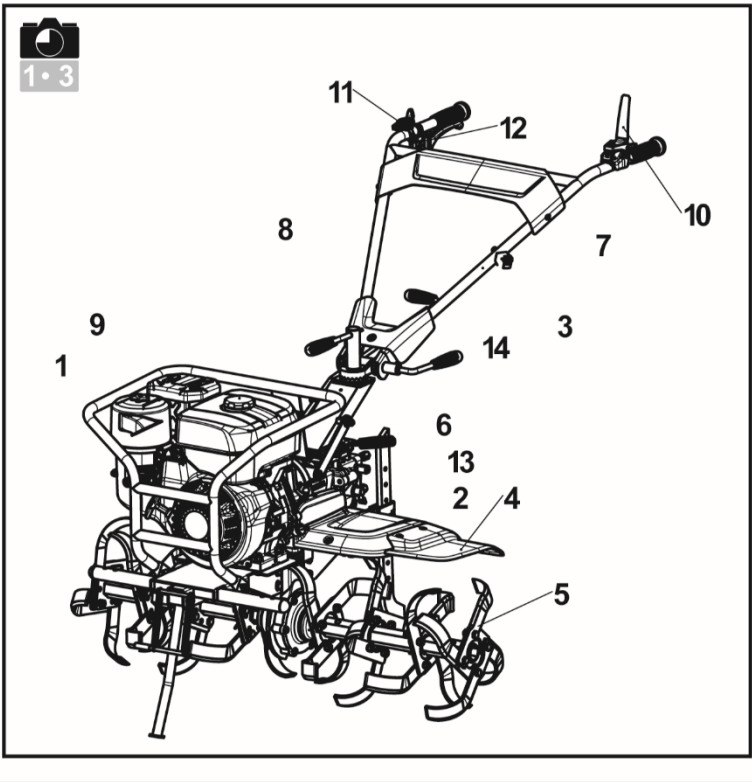

Husqvarna® Prod. year

Serial no.

Article no.

Model

Tilling scope

Tilling depth

Gear shifting

Engine displacement

Engine oil quality

Engine oil capacity

Gear box oil quality

Gear box oil capacity

Nominal power

Net weight

Fuel (octan/cetan)

**HUSQVARNA AB
SE-561 82 HUSKVARNA
SWEDEN**

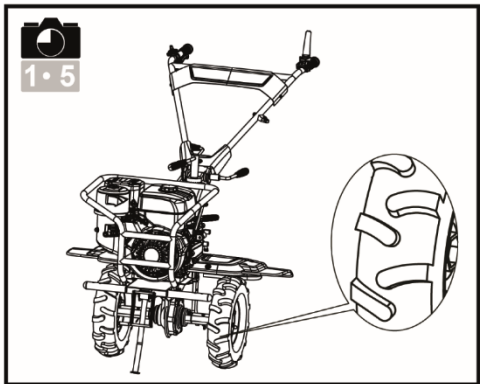
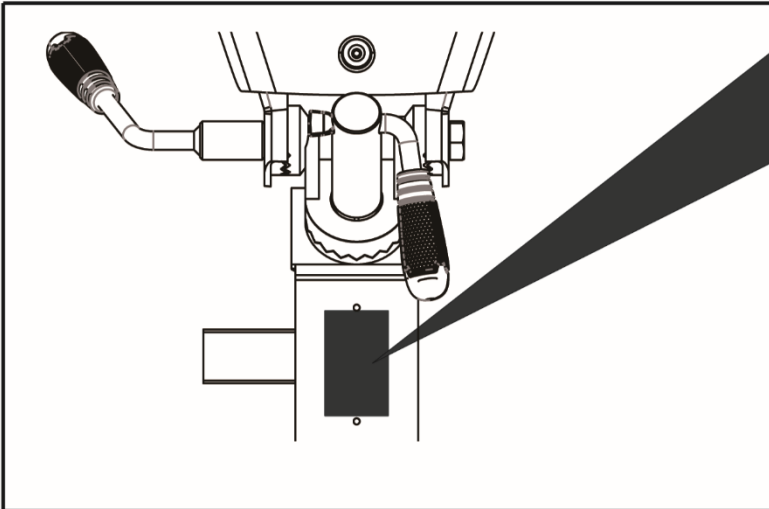

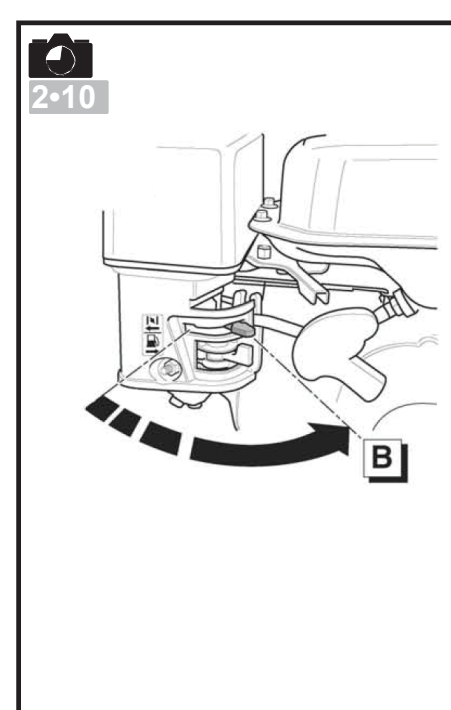
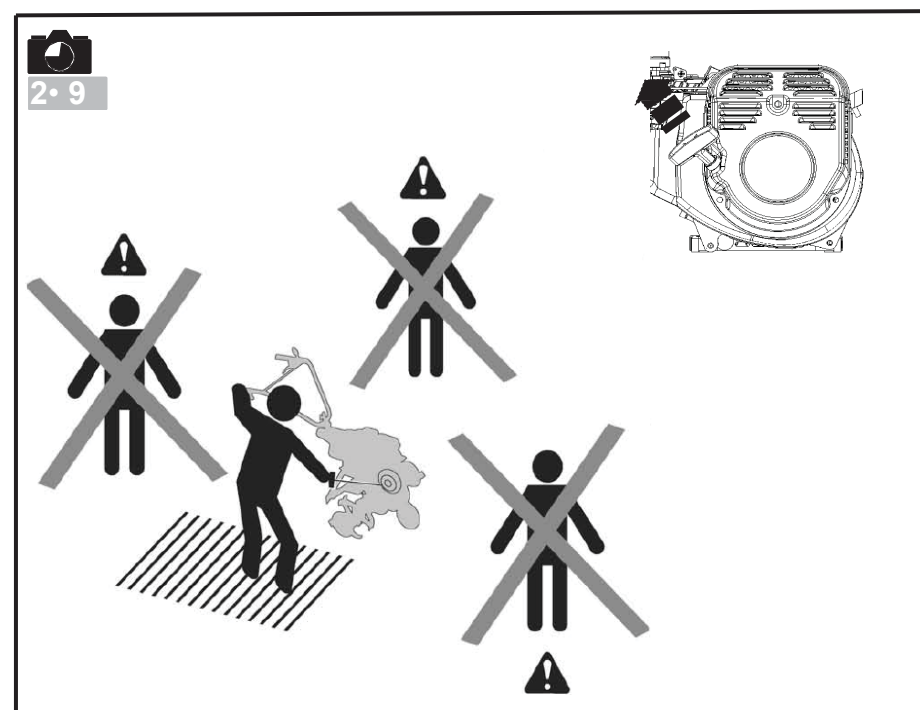
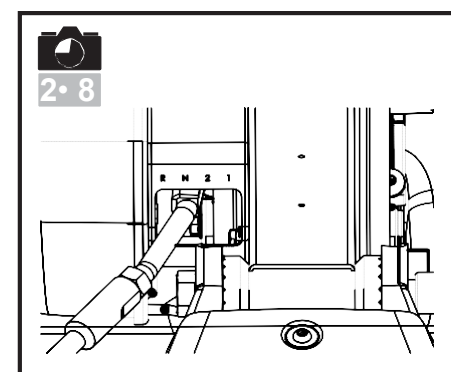
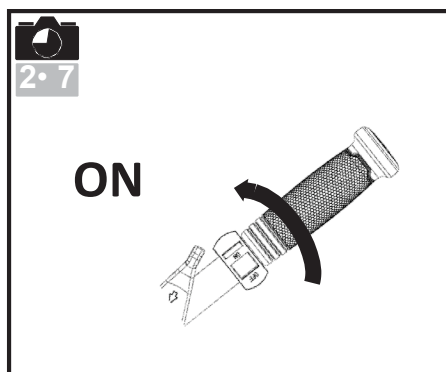
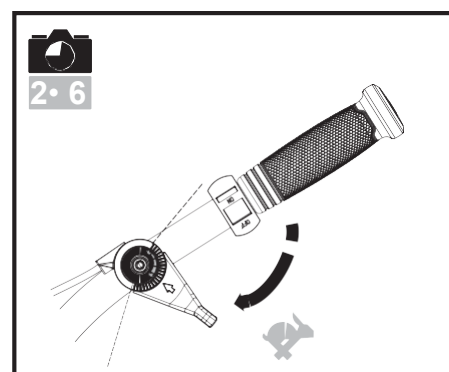
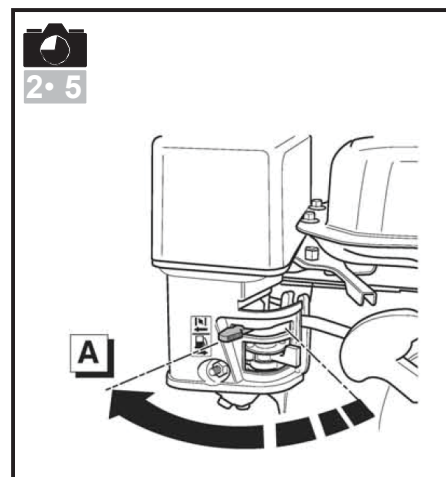
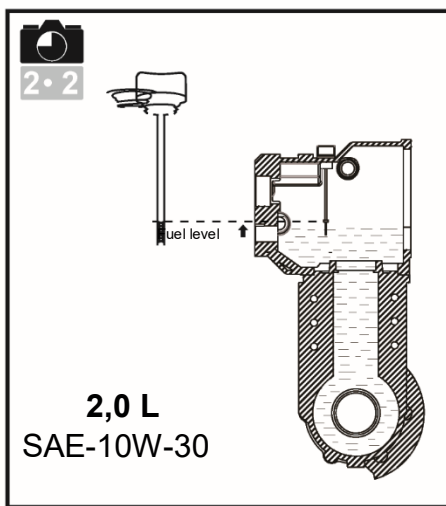
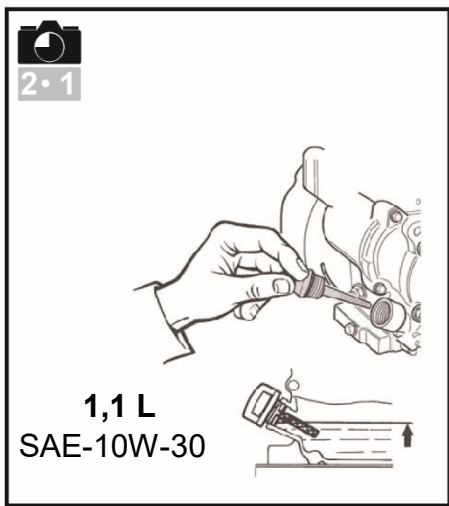



3•1

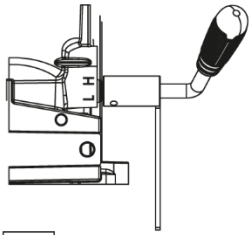

1 → H

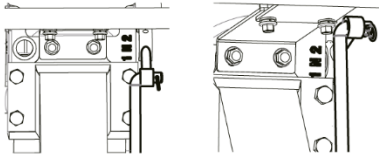

2 → 1,2

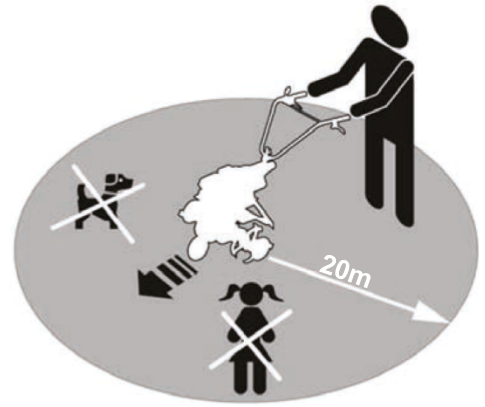
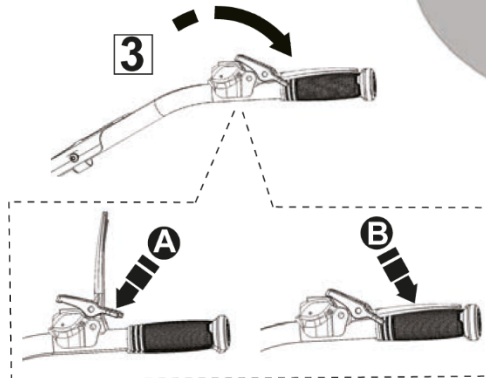

3•2

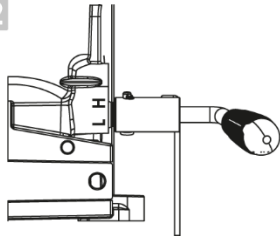

1 → L

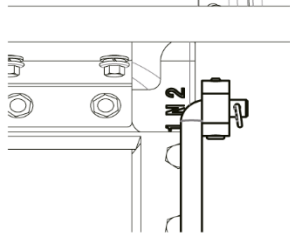

2 → N

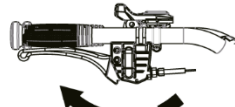

3 → R

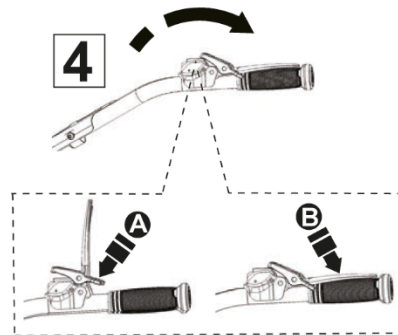

3•3

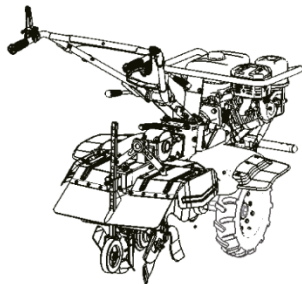

Ditcher

1 → L
2 → 1,2
3 → A,B

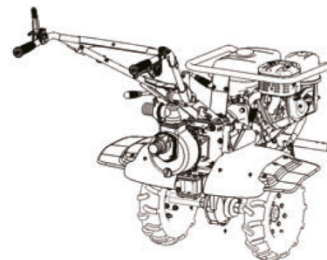

Pump

1 → H
2 → N
3 → A,B

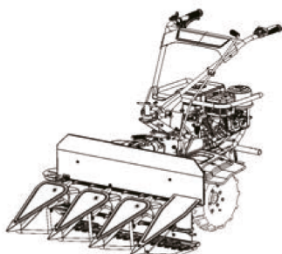

Swather

1 → L
2 → N
3 → R
4 → A,B

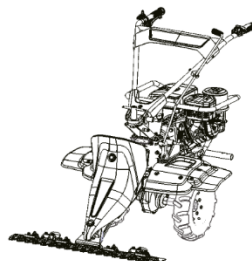

Grass cutter

1 → L
2 → N
3 → R
4 → A,B

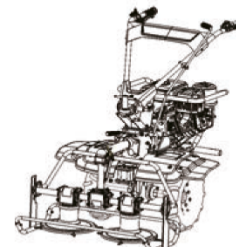

Mower

1 → L
2 → N
3 → R
4 → A,B

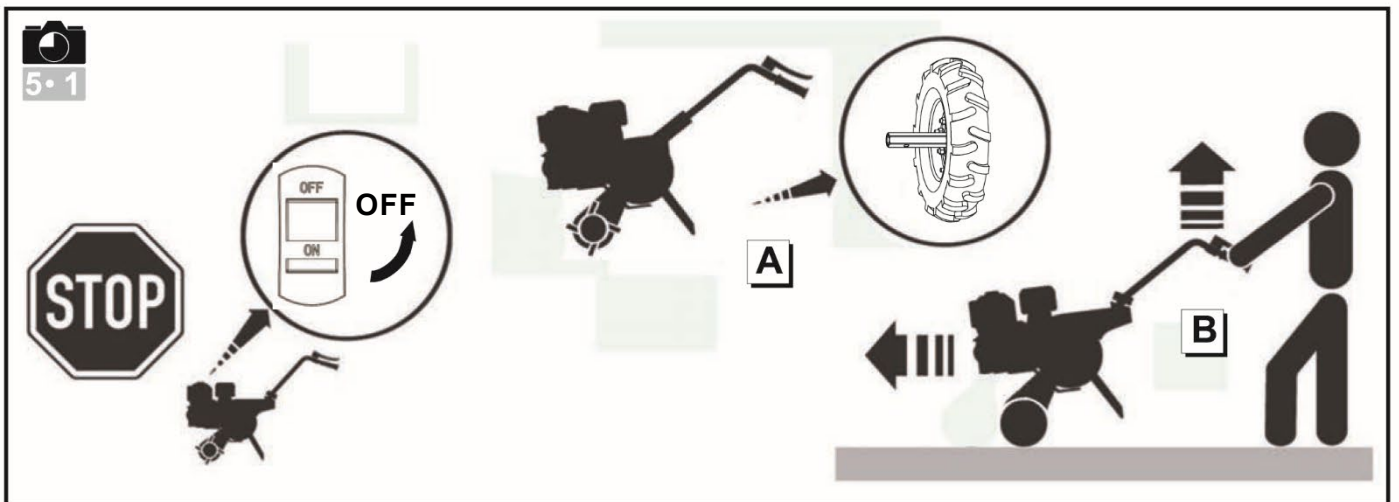
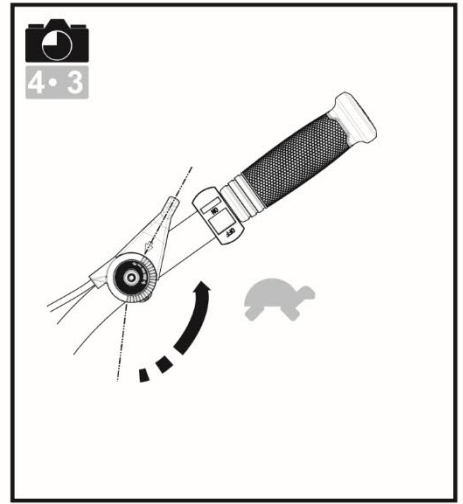
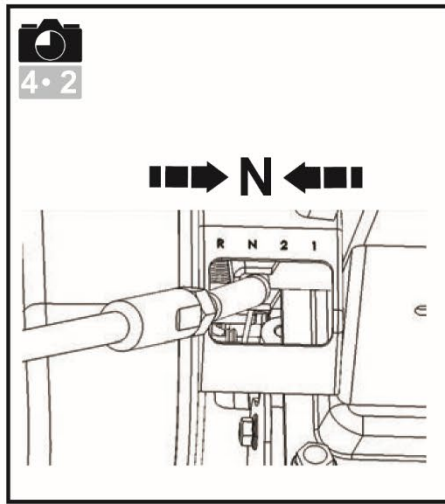

SAFETY PRECAUTIONS

Pay particular care to the sections marked as follows:



DANGER: This indicates a strong likelihood of serious or even fatal injury if the instructions are not followed.

WARNING: This indicates a risk of injury or damage to the equipment if the instructions are not followed.

NOTE: This indicates useful information.



This symbol reminds you to take care with certain operations.

If you have any problems or questions about the tiller, please contact Husqvarna dealer.



DANGER: The machine is designed for safe and reliable service if used as instructed. Before using your machine, please make sure you have understood the contents of this manual. Otherwise you could be injured and your equipment could be damaged.

Training / Information

Familiarise yourself with the correct use and the controls before using the machine. Know how to stop the engine rapidly.

The machine must always be used according to the recommendations given in the operator manual.

Remember that the user is responsible for any accidents or dangerous actions occurring to other people or their belongings. It is users responsibility to assess the potential risks of the ground to be cleared and take all precautions necessary to ensure it is safe, in particular on slopes and on loose, slippery on uneven ground.

Never allow children or people unfamiliar with these instructions to use the machine. There may be local laws which set a minimum age for users.

Never work when there are people, especially children, or animals within a radius of 20 meters of the machine; the operator must necessarily remain at the controls of the handles.

Do not use the machine if you have been taking medicine or other substances that might slow your reactions or make you drowsy.

Pay particular attention on hard ground, because the machine has the tendency to be much less stable than on cultivated ground.

Always wear sturdy, non-slip footwear and tight long trousers when working. Do not use the machine in bare feet or sandals. Ear protectors are recommended.

Use the machine for the purpose it is designed for tilling the ground.

Preparation

Carefully inspect the area where the machine is to be used and remove any objects that might be projected by the machine (stones, wire, glass, metal objects ...).

Before use, always inspect the machine to ensure that the tools are not worn or damaged, replace any worn or damaged parts.

Maintain the electrical cables that stop the engine in good condition so that you can be sure to turn the engine off.

Check that no fuel or oil are leaking.

Do not use the machine without covers and guards and ensure that all the fittings are tight.

Use

Never transport people on the machine.

Take care when starting the engine, following the manufacturer's instructions and keeping your feet away from the blade(s).

Stop the engine when the machine is not in use.

When holding the machine, walk don't run.

Pay close attention when pulling the machine towards you or reversing the direction of rotation (if liked).

Keep a safe distance from the rotating blades, set by length of the steering column.

Do not place your hands or feet near or beneath rotating parts.

The engine and the exhaust system become very hot during operating. Risk of burn injuries if touched.

If there is:

- abnormal vibration,
- a blockage,
- a problem engaging or disengaging the clutch,
- a collision with a foreign object,
- deterioration of the engine halt cable

Stop the engine immediately (if the engine halt cable is severed. Use the starter control as described in paragraph "start the engine" to stop the engine), let the machine cool down, unplug the spark-plug lead, inspect the machine and have the necessary repairs carried out by a Husqvarna workshop before using again.

Work only by daylight or in good artificial light.

Do not use the machine on slopes greater than 20°.

Work across the slopes, not up or down them.

Make sure to keep your feet on slopping ground, change direction very carefully.

Using accessories other than those recommended may make the machine dangerous and cause damage to your machine which will not be covered by your guarantee.

Maintenance / storage

Stop the engine before cleaning, inspecting, adjusting or maintaining the machine or changing the tool(s).

Stop the engine and use thick gloves when changing the tool(s).

Keep all nuts and bolts tight to ensure safe conditions of use.

To reduce fire risk, keep the engine, the silencer and the fuel storage area free of plants, waste oil, or any other inflammable material.

If the exhaust silencer is faulty, have it replaced, by a Husqvarna workshop.

Do not mend parts; replace them by the maker's own spares.

Replace the blades in complete sets to keep them balanced rotating.

For your own safety, do not alter the characteristic of your machine. Do not change the engine speed settings and do not run the engine at excess speeds. Regular maintenance is essential for safety and to maintain the level of performance.

Allow the engine to cool down before putting the machine away.

Danger! Fuel is highly inflammable!

Store fuel in containers specially designed for it. Always fill the tank outdoors and do not smoke while doing it.

Do not unscrew the fuel cap or top up with fuel while the engine is running or still hot.

If fuel is split on the ground do not try to start the engine; Carry the machine elsewhere and avoid all naked flames.

Store the machine in a dry place. Never store the machine in a building where the machine can reach a flame, spark or source of intense heat.

Replace the caps of the fuel tank and the fuel can correctly.

Limit the amount of fuel in the tank to reduce spillage.

Do not run the engine in a confined space where carbon monoxide vapour might accumulate.

Carbon monoxide can be fatal. Ensure good ventilation.

Moving, handling, transporting

Any action on the machine apart from ground digging must be performed with the engine stopped.

Except when (ground digging) the machine must be moved by using the transport wheel as described in "Moving" chapter.

Handling: do not try and lift the machine. The machine's weight is indicated on the type plate at the mid of this manual. Use a method of handling adapted to the weight of the machine and to the situation to guarantee the safety.

When loading or unloading the machine to or from a trailer, use a suitable ramp. Lash the machine down correctly for safe transport.

DEFINITIONS OF PICTOGRAMS



Warning
Danger

Warning
Keep safe distance

Warning
Rotating tools

Warning
Consult the Operator Manual and remove the sparkplug before performing any work

Warning
Read the Operator Manual

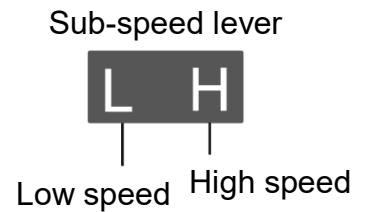
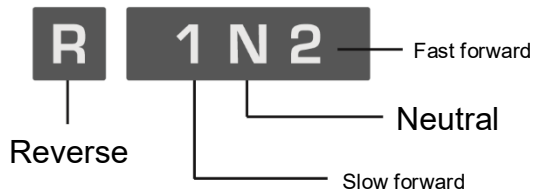

Throttle control

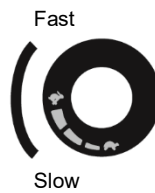

Stop switch

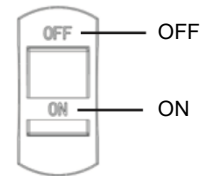

Ear protection must be used.

TECHNICAL INFORMATION

	TF545P
Tilling width, mm	1100
Tilling depth, mm	150 - 300
Engine	WM177F/P
Fuel	Petrol
Fuel tank capacity, liters	6,0
Oil tank capacity, litre	1,10
Cylinder displacement, cm ³	270
Max power hp (kW) @ rpm	8,16 (6,0) @3600
Gears	H, L, R, N, 2, 1
Oil capacity gearbox, liters	2,00
Gross weight, kg	145
Net weight, kg	130
Packaging size, mm	1030x690x850

IMPORTANT! When the service life of this product has been served and it is no longer used it should be returned to the dealer or to an applicable station for recycling.

IMPORTANT! We reserve the right to change specifications and designs without prior notice so as to implement improvements. Note that no legal claims are valid on the basis of information in this manual. Use only genuine parts for repairs. The warranty is not valid if non genuine parts are used.

UNPACKING/ ASSEMBLY

Note: In the constant desire to improve the products, the manufacturer states that the whole of this manual is not contractual and reserves the right to modify the specifications of the machines without notice.



Unpacking



WARNING:

Take care not to cut the cables or scratch the machine's paintwork when cutting the edges of the case.

Ref.	Contents of the case
A	Engine Parts
B	Sub Holder 1st
C	Holder Main Comp
D	Lower Tidy Cover
E	Drag Bar
F	Tine Cover
G	Tine Cover Bracket FR.
H	Lever Shifting
I	Blades
J	Wheel
K	Connection Joint
L	Extension Cover
M	Side Cover
N	Locking Handle
O	Tine Cover Bracket RR.
P	Rubber Cable Holder
Q	Connecting Plate
R	Hardware Bag Tines only
S	Hardware Bag
T	Tool Bag



1•2

Assembling



WARNING:

Inappropriate assembly of this rotary tiller could cause severe injuries. Ensure that you follow all the instructions carefully.



Fitting the tine blades.

Illustrations only shows assembly of the tin blades on the right side. Make sure that sharp edges face one side on both Right and Left side tines.

Note: Please pay attention to distinguish the Sub Holder 1st and Sub Holder 2nd.



Fitting the connecting joint.



Fitting the drag bar.



Fitting the handle bar.



Adjusting the position of the handle bar.



Fitting the clutch control.

Turn to proper side and fasten the bolt.



Fitting the lower tidy cover.

1. Tidy the cables,
2. Put on the rubber holder properly,
3. Put on the cover, and fasten with bolt.



Fitting the tine cover.



Do not tighten the bolt immediately after installed. Install all 4 bolts and nuts first, then tighten one by one.



Fitting the shifting lever.



PTO assemble for accessories.



WARNING:

After assembling the machine completely, tighten all the bolts and screws with the moderation: do not overtighten.

Note: Any dismantling operation must only be performed by a Husqvarna workshop.



Description of the components

- 1- Engine
- 2- Tine cover
- 3- Handle
- 4- Extension cover
- 5- Blades
- 6- Drag bar
- 7- Upper tidy cover
- 8- Lever shifting
- 9- Bumper
- 1- Clutch control
- 11- Throttle control
- 12- Reverse control
- 13- Side cover
- 14- Lower tidy cover



Type plate

1•4



Transport wheel

1•3

Change the blades with wheels when transporting

STARTING THE MACHINE



2•1

Filling with engine oil and checking the level



2•2

Filling with gearbox oil



2•3

Topping up the petrol

Recommend to USE Octane Value over 90



2•4

Open the fuel tap



2•5

Set the choke in position A



2•6

Throttle control

Put the lever to:



2•7

Set the on/off switch to ON



2•8

Shifting lever

Put the lever to gear N.



2•9

Pull the recoil start handle



WARNING:

When the machine starts, remain within the safety zone.



2•10

Set the choke in position B

USE



Forward



It is essential to let ou the clutch before using reverse



Maintain a safety zone of 20 m in radius around the machine



Reverse



It is essential to let ou the clutch before using reverse



Maintain a safety zone of 20 m in radius around the machine



The use of reverse is dangerous. Ensure that there are no obstacles behind you and reduce the engine revs before engaging the clutch



Tiller working direction with accessories and gear control

STOPPING



Stopping the rotating tools

Release the clutch lever.



Putting the shifting lever to •N•



Reduce the throttle

Set the throttle control to:



Stopping the engine

Set the on/off switch to OFF



Close the fuel nap

MAINTENANCE TABLE

Daily check

Before starting the engine, check the following points.

- There must be no loosened or broken nuts or bolts.



- Cleanliness of the air filter element



Do not use inflammable solvent to clean the foam air filter element.



- Check lub. oil level

- No leaks of petrol or lub.



- Sufficient petrol

- Keep the machine clean.

- Environment protection.

- No abnormal vibrations or excessive noise.

After the first 20 hours of every month

- Change the lub. Oil of engine and gearbox.

Every 50 hours of every 3 months

- Clean the air filter * (2 Fig. 4.6).

Every 100 hours or every 6 months

- Clean the fuel filter.
- Change the lub. Oil of engine and gearbox.
- Clean the spark plug.
- Clean the spark plug cap.

Every 300 hours or once a year

- Replace the air filter *.
- Check the play in the valve * *.
- Replace the spark plug.
- Clean the fuel filter * *.
- Clean combustion chamber * *.
- Check the fuel circuit * *.

* Clean more often in condition of use where the air is dusty or laden with aerial debris.

** Not essential except in the event of performance problems (to be conducted by a Husqvarna workshop).



EC DECLARATION OF CONFORMITY



For the following machinery

Product name: Gasoline powered motor hoes
Commercial name: N/A
Function: motor hoes (without driven wheels)
Type: Gasoline
Model No.: TF545P
Serial No.:

is herewith confirmed to fulfill all the relevant provisions of

Machinery Directive (2006/42/EC)

and the following harmonized standard have been complied with

EN 709: 1997 + A4: 2009
EN 709: 1997 + A4/AC:2012

is herewith confirmed to fulfill all the relevant provisions of

Electromagnetic Compatibility Directive (2014/30/EU)

and the following harmonized standard have been complied with:

EN ISO 14982: 2009

Responsible for marking this declaration is the

Manufacturer's Name : Husqvarna AB
Manufacturer's Address : SE-561 82 HUSKVARNA SWEDEN

Person responsible for compiling the technical files established within the EU

Name, Surname : Husqvarna AB
Address : SE-561 82 HUSKVARNA SWEDEN

Person responsible for making this declaration

Name, Surname : Claes Losdal
Position/Title : R&D Director
Place : Huskvarna
Date : 2017-12-22



Husqvarna®

(Company stamp and legal signature)

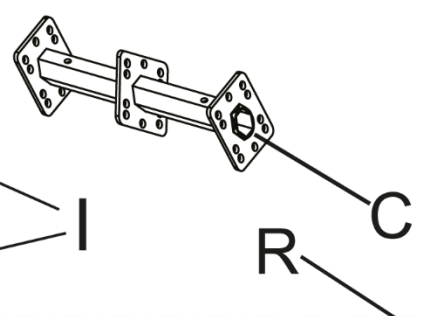
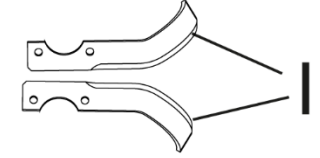
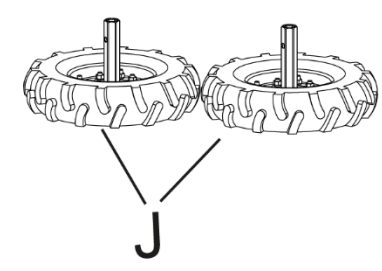
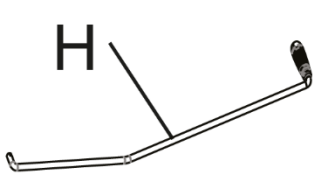
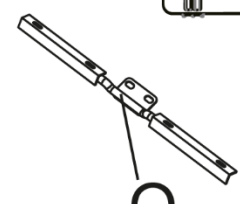
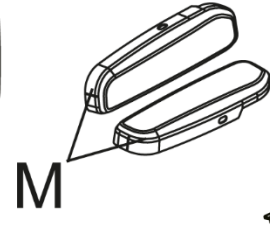
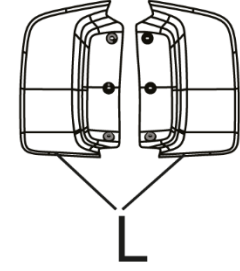
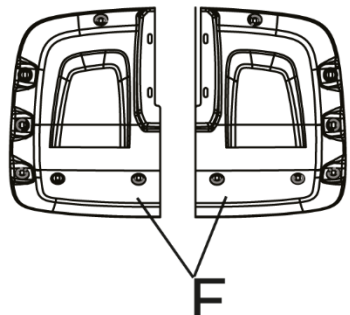
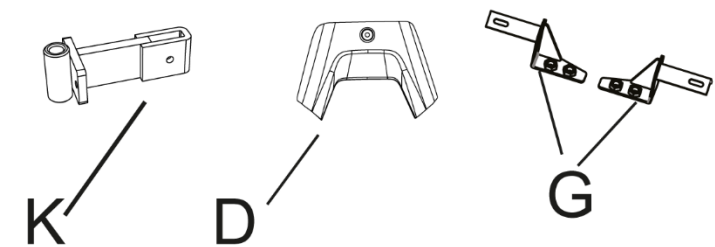
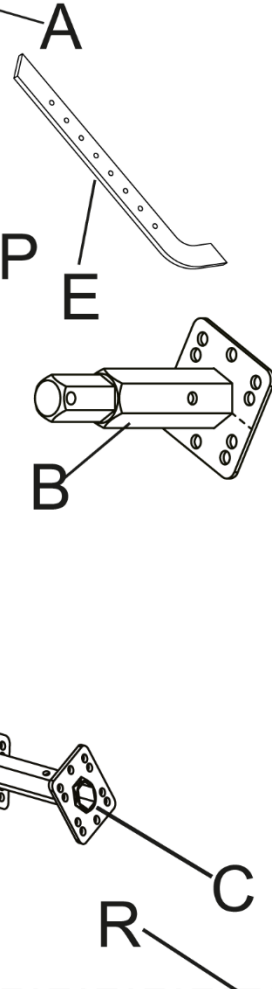
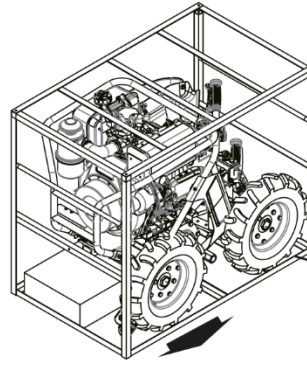
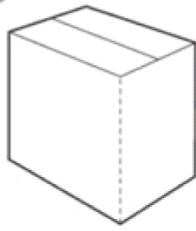

- ① X17
- ② X4
- ③ X4
- ④ X4
- ⑤ X23
- ⑥ X6
- ⑦ X2
- ⑧ X4
- ⑨ X16
- ⑩ X10
- ⑪ X2
- ⑫ X6

- Sólo para fresas
- ⑩ X2
 - ⑬ X2
 - ⑭ X2
 - ⑮ X2
 - ⑯ X32
 - ⑰ X32
 - ⑱ X32

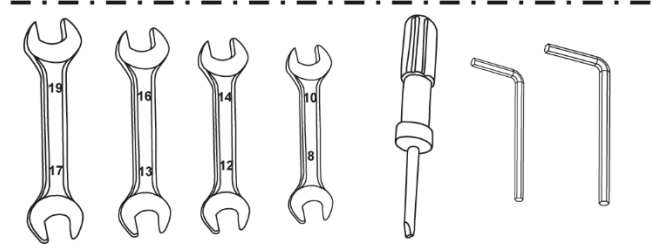

S

T

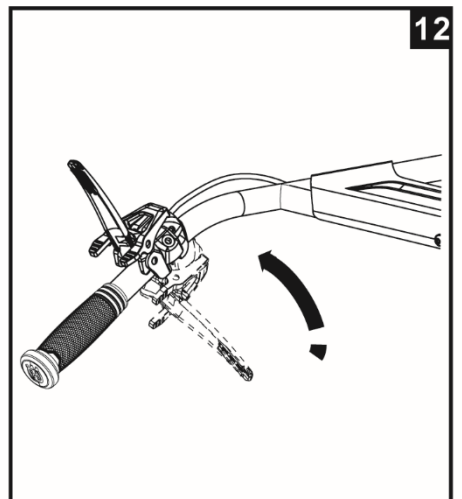
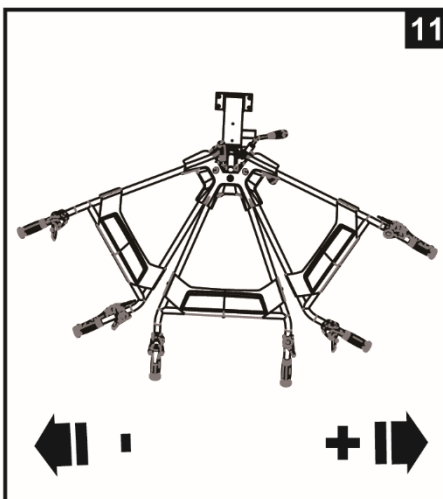
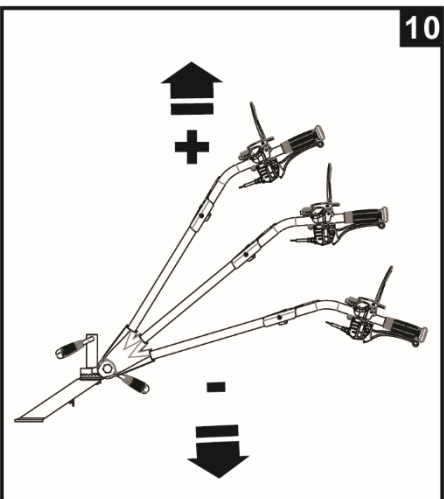
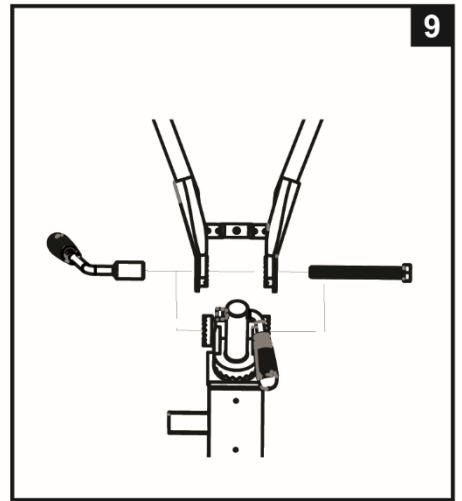
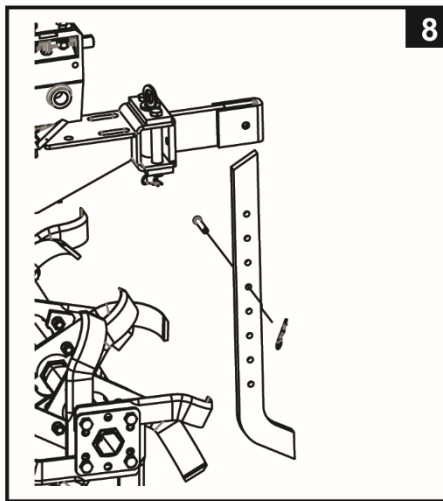
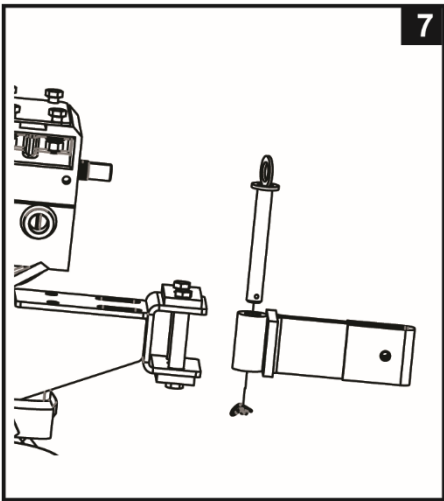
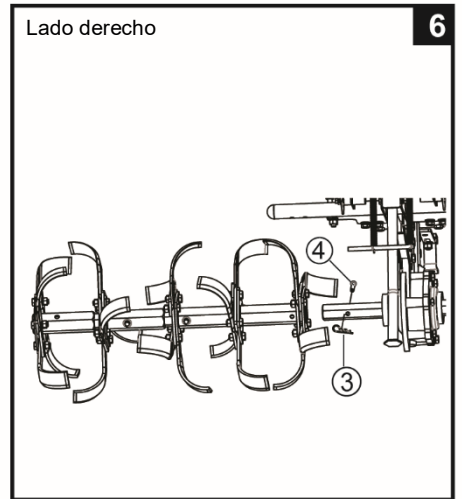
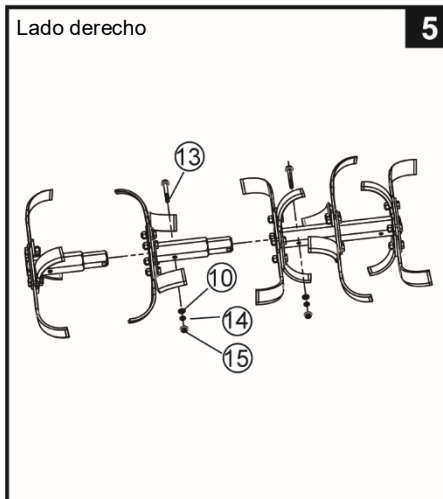
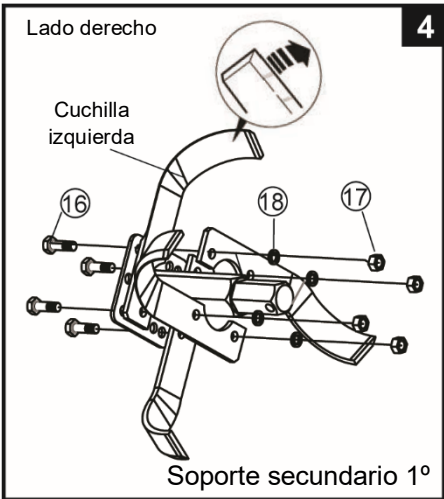
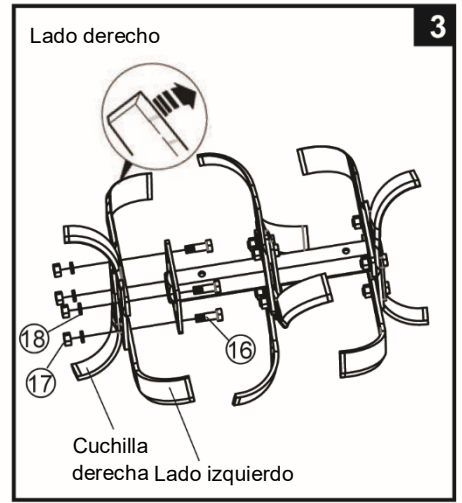
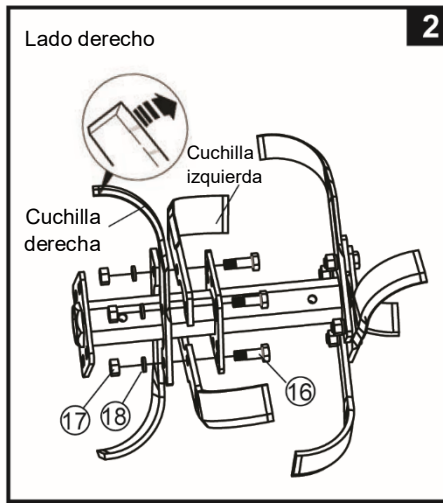
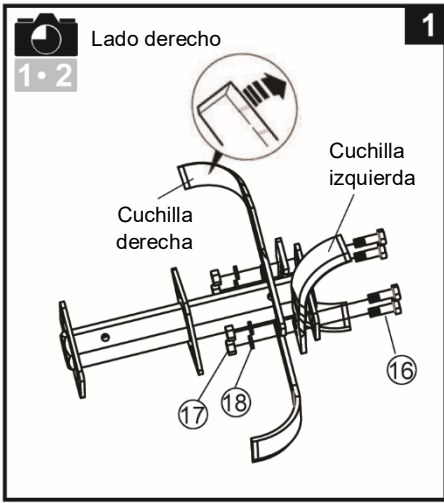

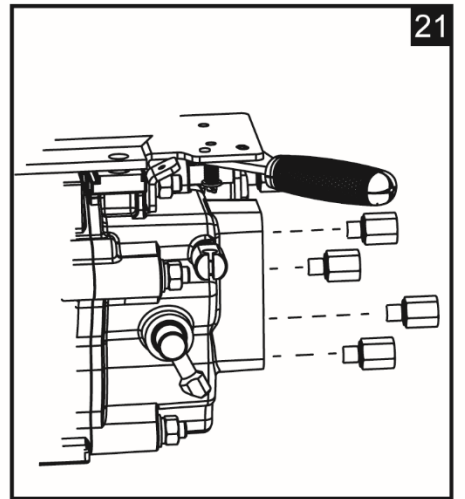
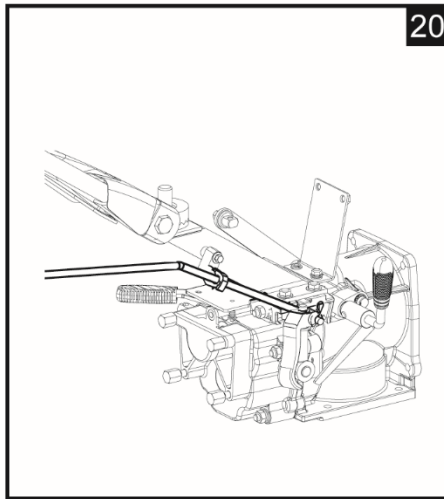
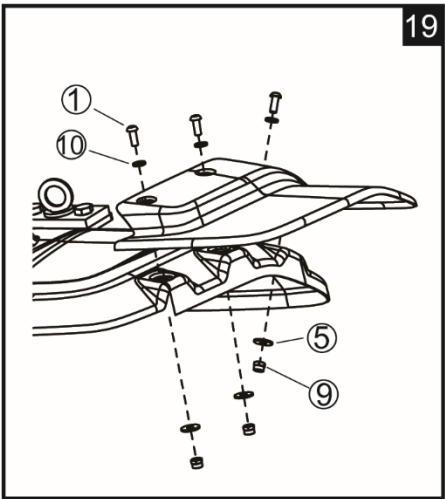
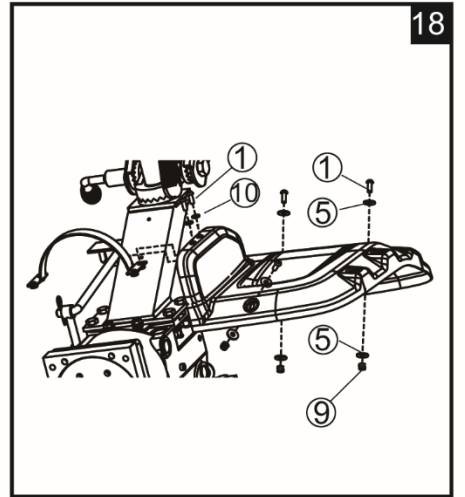
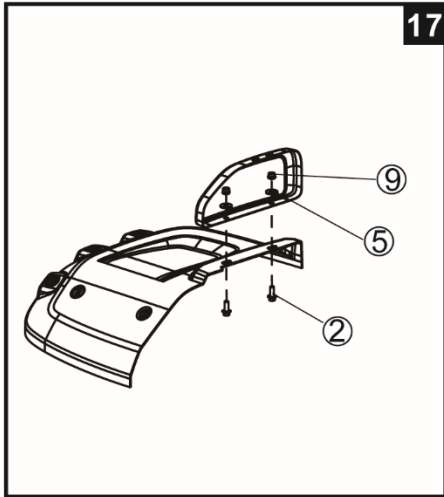
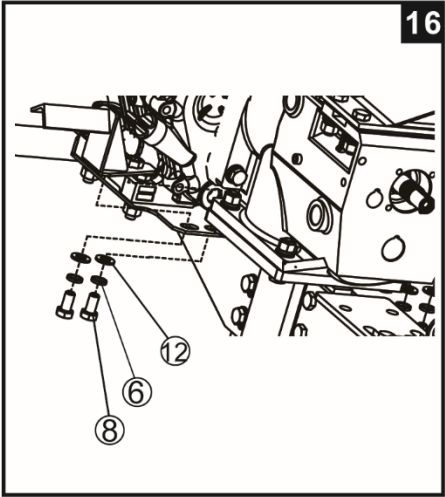
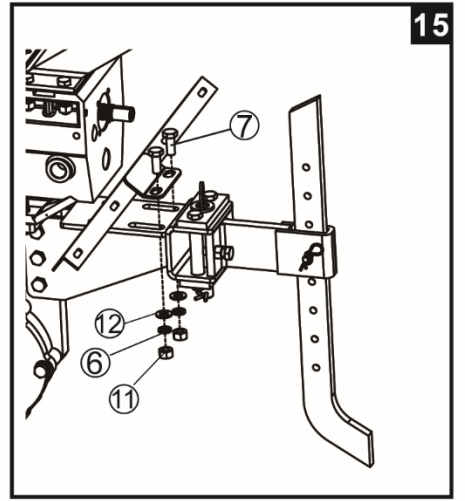
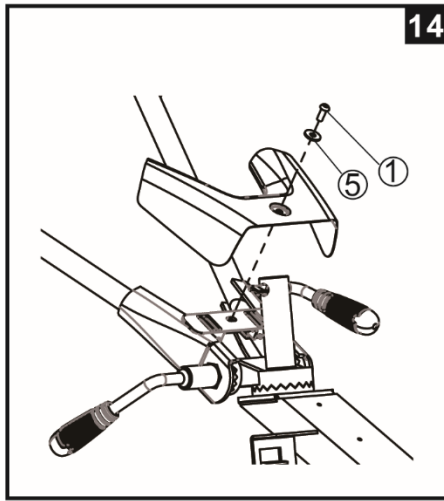
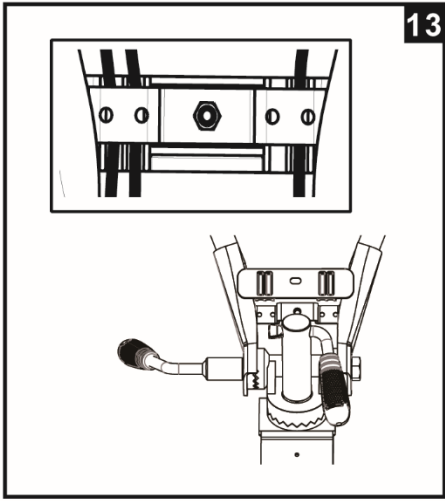



1-3

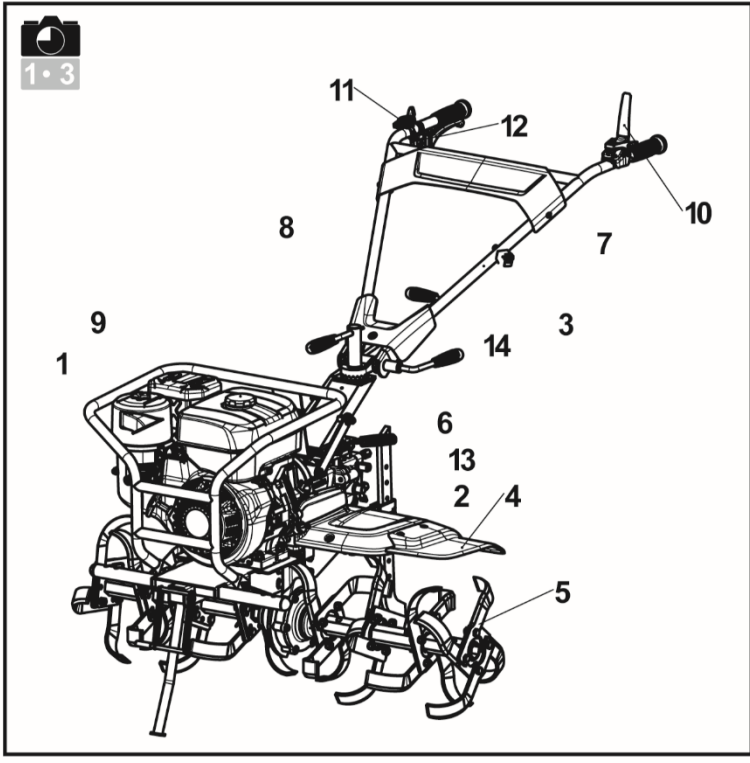

1-4

Husqvarna Año prod.

N.º de serie

N.º de artículo

Modelo

Anchura de trabajo

Profundidad de trabajo

Cambio de marchas

Cilindrada del motor

Calidad del aceite del motor

Capacidad de aceite del motor

Calidad del de la caja de engranajes aceite

Capacidad de aceite de la caja de engranajes

Potencia nominal

Peso neto

Combustible

**HUSQVARNA AB
SE-561 82 HUSKVARNA
SUECIA**

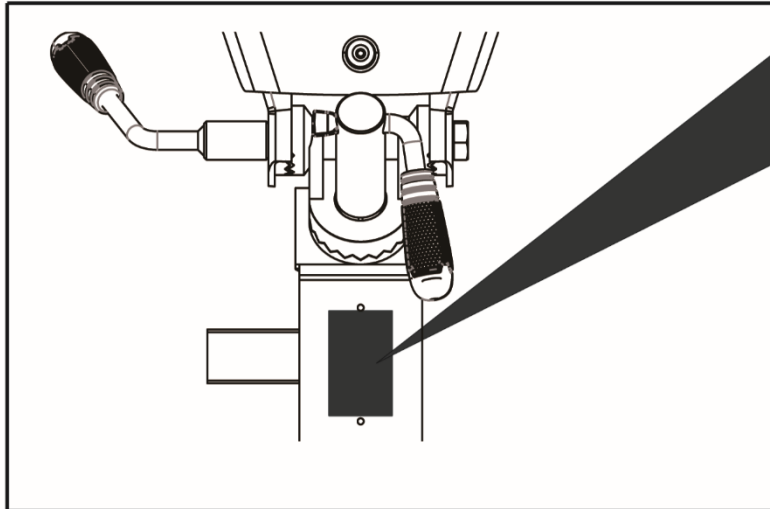

1-5

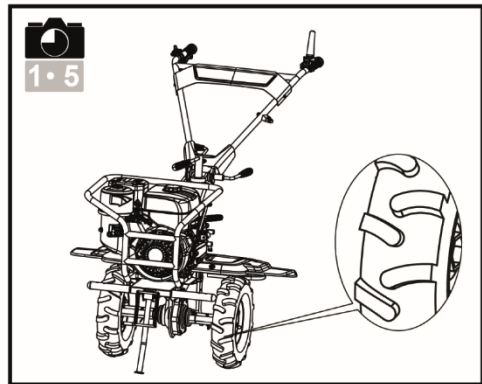

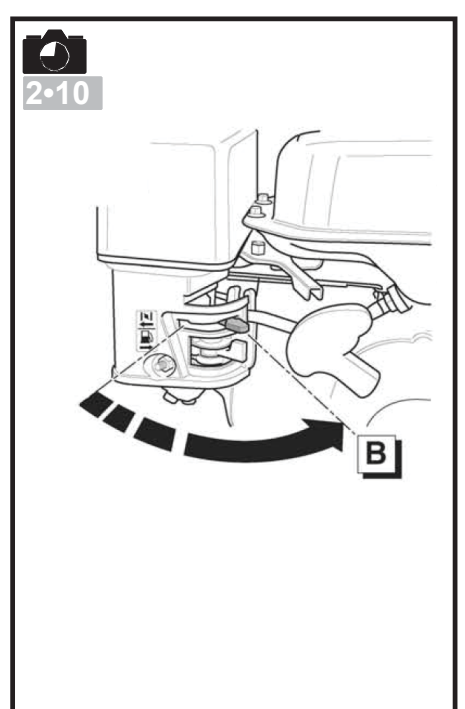
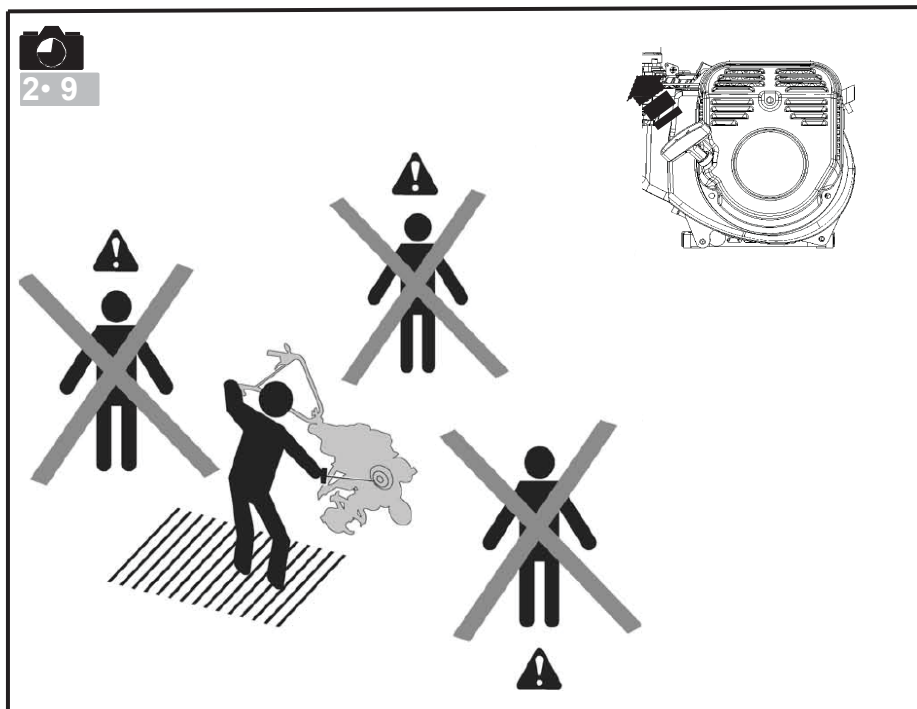
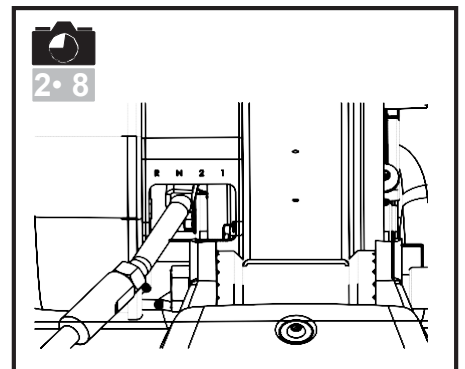
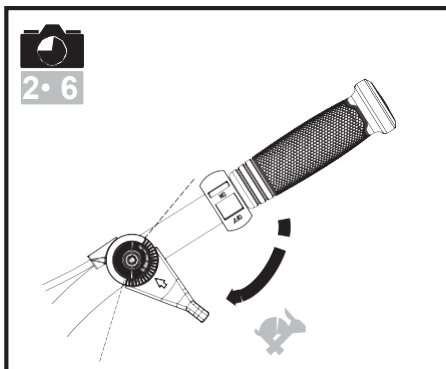
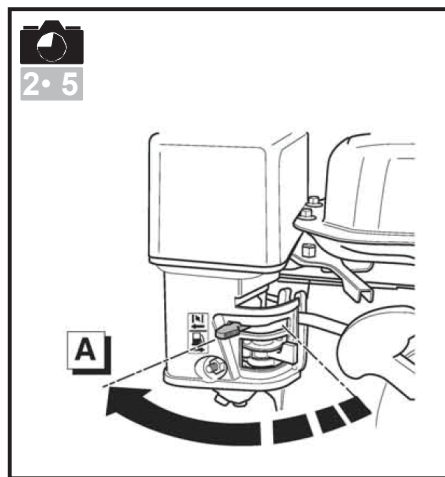
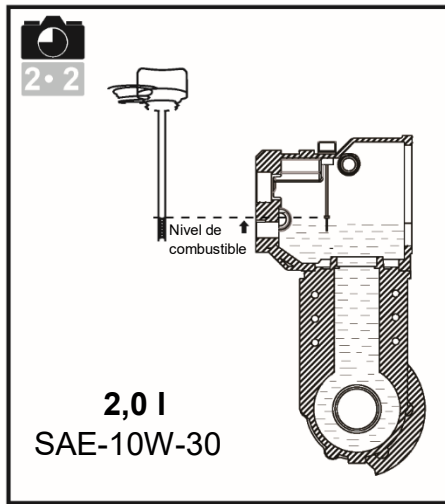
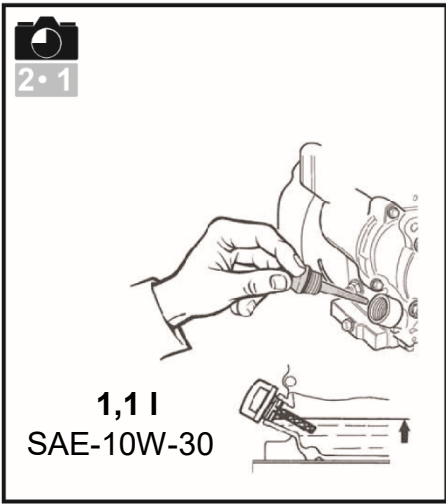



3•1

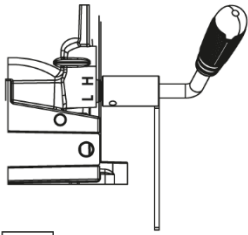

1 → H

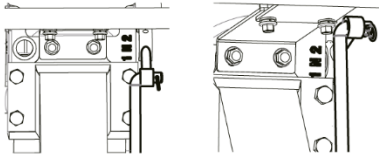

2 → 1,2

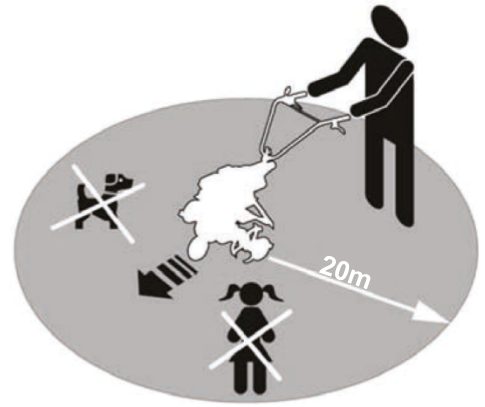
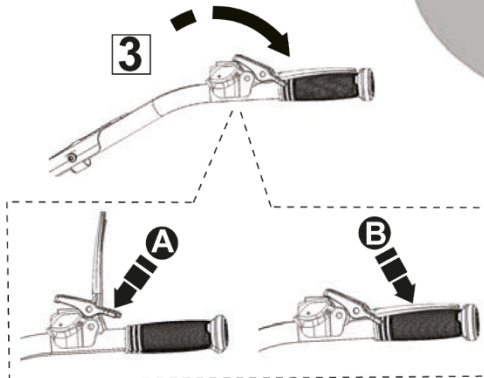

3•2

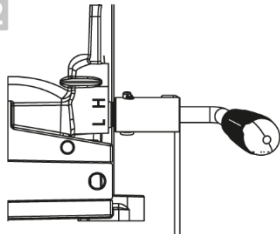

1 → L

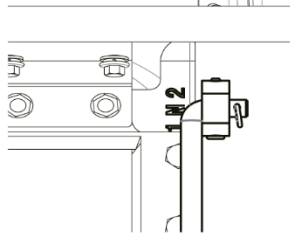

2 → N

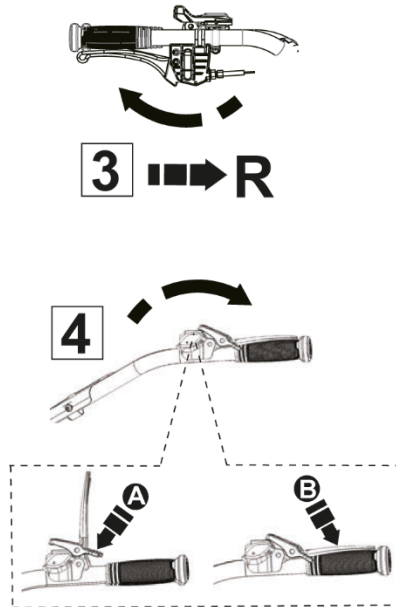

3•3

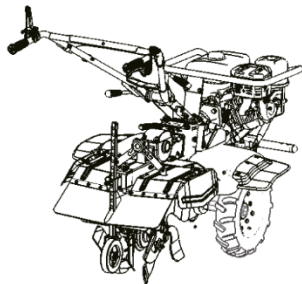

1 → L
2 → 1,2
3 → A,B

Zanjadora

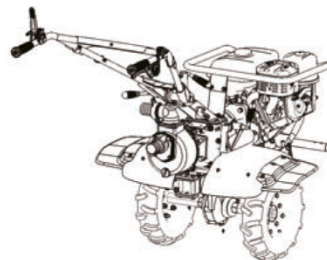

1 → H
2 → N
3 → A,B

Bomba

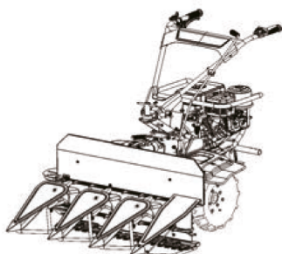

1 → L
2 → N
3 → R
4 → A,B

Segadora

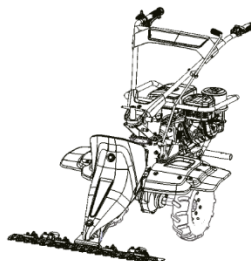

1 → L
2 → N
3 → R
4 → A,B

Desbrozadora

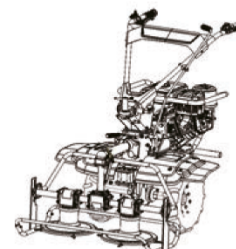

1 → L
2 → N
3 → R
4 → A,B

Cortacésped

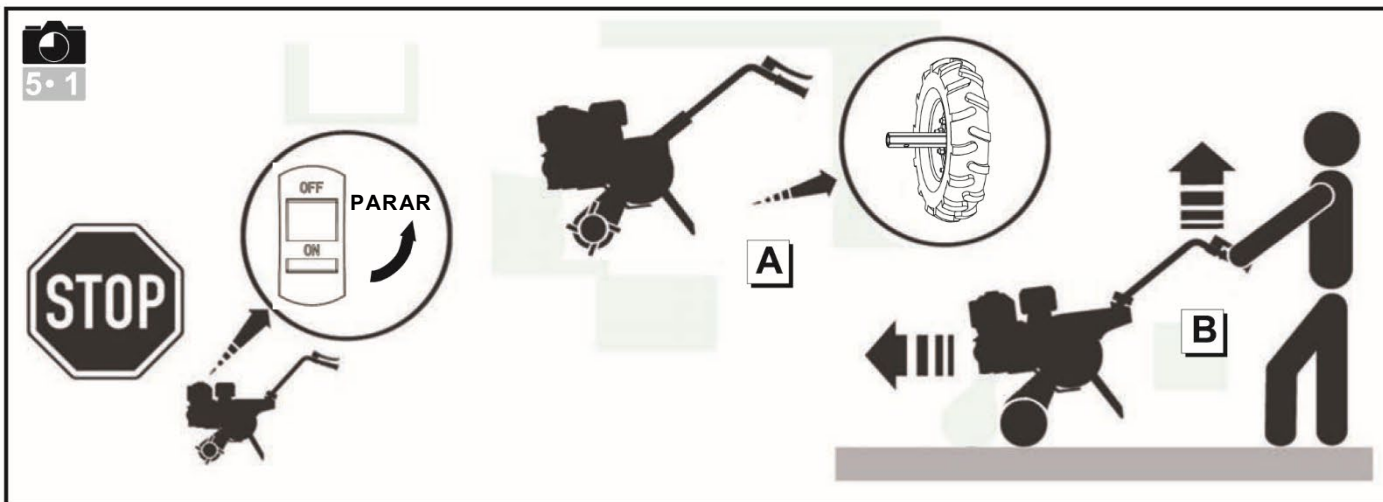
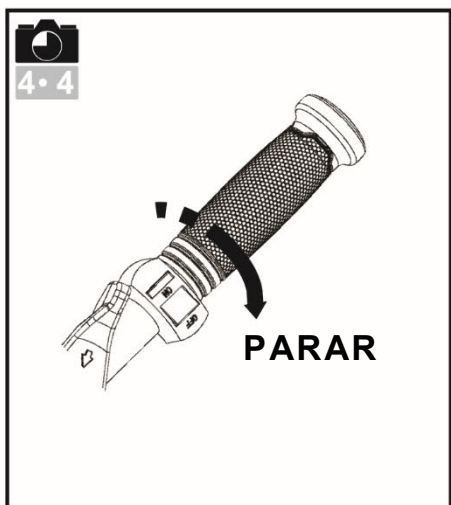
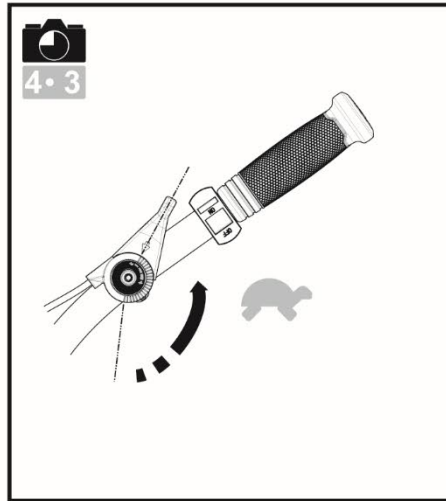
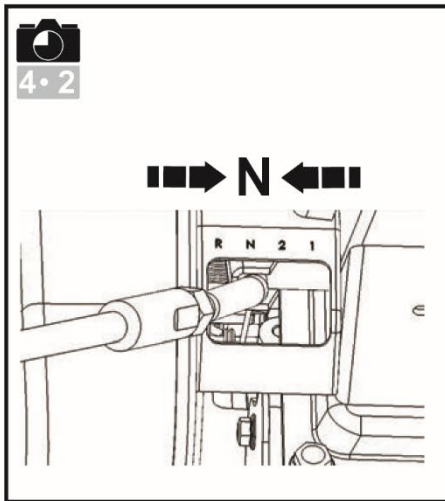
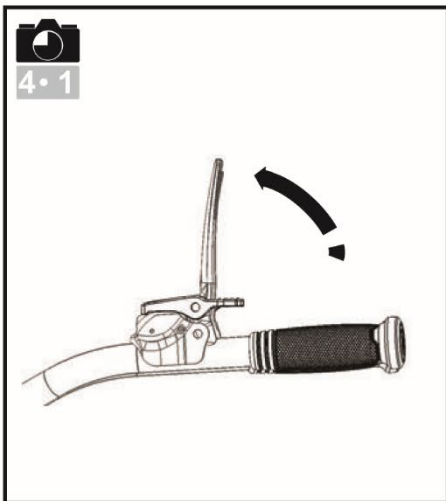

PRECAUCIONES DE SEGURIDAD

Se debe prestar especial atención a las secciones señaladas de la manera siguiente:



PELIGRO: Indica que la probabilidad de sufrir daños graves o incluso mortales en caso de no seguir la instrucción es muy alta.

ADVERTENCIA: Indica que existe el riesgo de sufrir lesiones o causar daños materiales en caso de no seguir las instrucciones.

NOTA: Indica información de utilidad.



Este símbolo le recuerda que debe tener cuidado con ciertas operaciones.

Si tiene problemas o preguntas sobre la motoazada, póngase en contacto con su proveedor Husqvarna.



PELIGRO: La máquina se ha diseñado para que su uso sea fiable y seguro si se siguen las instrucciones. Antes de utilizar la máquina, asegúrese de haber entendido el contenido de este manual. De lo contrario, podría sufrir lesiones y el equipo podría resultar dañado.

Formación/Información

Familiarícese con el uso correcto y con los controles antes de utilizar la máquina. Aprenda a detener el motor rápidamente.

La máquina debe utilizarse siempre según las recomendaciones del manual de usuario.

Recuerde que el usuario es responsable de los accidentes o acciones peligrosas en los que se vean afectadas otras personas o sus pertenencias. Es su responsabilidad evaluar los riesgos potenciales del terreno en el que se va a trabajar así como adoptar las medidas de precaución necesarias para garantizar la seguridad, en particular en pendientes y en terrenos irregulares, resbaladizos o inestables.

Nunca permita utilizar la máquina a niños o personas que no estén familiarizados con estas instrucciones. Pueden existir leyes locales que establezcan una edad mínima para los usuarios.

Nunca trabaje si hay animales o personas, especialmente niños, a menos de 20 metros de la máquina; el operador debe tener en todo momento el control de la máquina.

No utilice la máquina si ha estado tomando medicamentos u otras sustancias que puedan mermar su capacidad de reacción o que puedan producir sueño.

Preste especial atención sobre terrenos duros, ya que la máquina suele ser mucho menos estable que sobre terrenos cultivados.

Cuando trabaje, utilice siempre calzado antideslizante y resistente, y pantalones largos ceñidos. No utilice la máquina descalzo o con sandalias. Se recomienda el uso de protectores auriculares.

Utilice la máquina según su uso previsto: labrar la tierra.

Preparación

Inspeccione detenidamente la zona en la que se va a utilizar la máquina y retire todos los objetos que puedan salir despedidos por la acción de esta (piedras, alambre, cristal, objetos de metal, etc.).

Antes de usarla, revise siempre la máquina para asegurarse de que los implementos no están

desgastados ni dañados, sustituya las piezas que estén desgastadas o dañadas.

Los cables eléctricos utilizados para detener el motor deben conservarse en buen estado para poder parar el motor cuando sea necesario.

Asegúrese de que no haya fugas de combustible o aceite.

No utilice la máquina sin las cubiertas o protecciones y asegúrese de que todas las uniones estén bien apretadas.

Uso

Nadie debe trasladarse sobre la máquina.

Tenga cuidado al arrancar el motor, siga las instrucciones del fabricante y mantenga los pies alejados de las cuchillas.

Detenga el motor cuando no utilice la máquina.

Cuando use la máquina, camine y no corra.

Tenga mucho cuidado al tirar de la máquina hacia usted o al invertir la dirección de rotación (si lo prefiere).

Guarde una distancia de seguridad con respecto a las cuchillas giratorias; esta distancia viene determinada por la longitud de la columna de dirección.

No coloque las manos ni los pies cerca o debajo de las piezas giratorias.

El motor y el sistema de escape pueden calentarse mucho durante el funcionamiento. Riesgo de lesiones por quemaduras si se tocan.

Ante lo siguiente:

- Vibración anómala.
- Bloqueo.
- Problemas para engranar o desengranar el embrague.
- Colisión con un objeto extraño.
- Deterioro del cable de parada del motor.

Pare el motor inmediatamente (si el cable de parada del motor está roto, utilice el control del mecanismo de arranque tal como se describe en el apartado "Arranque del motor" para detener el motor), deje que la máquina se enfríe, desconecte el cable de la bujía, revise la máquina y llévela a un taller Husqvarna para efectuar las reparaciones oportunas antes de volver a utilizarla.

Cuando use la máquina, hágalo solo de día o con buena iluminación artificial.

No utilice la máquina en pendientes de más de 20°.

En pendientes, trabaje siempre de lado, no suba ni baje por ellas.

Apoye bien los pies en pendientes y cambie de dirección con mucho cuidado.

El uso de accesorios distintos a los recomendados aumenta el nivel de peligrosidad de la máquina y puede causar daños en la unidad que no estarán cubiertos por la garantía.

Mantenimiento y almacenamiento

Pare el motor antes de limpiar, revisar, ajustar o realizar tareas de mantenimiento en la máquina, o de cambiar los implementos.

Detenga el motor y utilice guantes gruesos al cambiar los implementos.

Para garantizar la seguridad durante el uso de la máquina, todos los pernos y las tuercas deben estar bien apretados.

Para reducir el riesgo de incendio, mantenga el motor, el silenciador y el depósito de combustible

sin restos de vegetación, aceite residual o cualquier otro tipo de material inflamable.

Si el silenciador del escape está defectuoso, acuda a un taller Husqvarna para sustituirlo.

No repare los componentes, sustitúyalos por repuestos originales.

Sustituya cada cuchilla en su conjunto para mantenerlas equilibradas.

Por su propia seguridad, no modifique las características de su máquina. No cambie los ajustes de régimen del motor ni lo revolucione en exceso. Llevar a cabo las tareas de mantenimiento periódico es fundamental para garantizar la seguridad y mantener el nivel de rendimiento.

Deje que el motor se enfríe antes de guardar la máquina.

Peligro: El combustible carburante es altamente inflamable.

Guarde siempre el combustible en envases especialmente diseñados para ello. Llene siempre el depósito al aire libre y no fume mientras lo haga.

No desenrosque el tapón de combustible ni llene el depósito con el motor en marcha o aún caliente.

Si se vierte combustible en el suelo, no arranque el motor; lleve la máquina a otro lugar y evite la cercanía de llamas abiertas.

Guarde la máquina en un lugar seco. Nunca guarde la máquina en un lugar en el que la máquina pueda entrar en contacto con una llama, una chispa o una fuente de calor intenso.

Vuelva a tapar debidamente el depósito de combustible y el bidón de carburante.

Con el fin de evitar derrames, reduzca al mínimo la cantidad de combustible presente en el depósito.

No ponga en marcha el motor en un recinto cerrado para evitar que el monóxido de carbono se acumule.

El monóxido de carbono puede resultar letal. El lugar debe estar bien ventilado.

Desplazamiento, manipulación y transporte

A menos que utilice la máquina para labrar, cualquier otra operación debe realizarse con el motor parado.

Excepto cuando la máquina se esté utilizando para labrar, deberá desplazarse con ayuda de la rueda de transporte tal como se describe en el capítulo "Desplazamiento".

Manipulación: no trate de levantar la máquina. El peso de la máquina figura en la placa de identificación al final de este manual. A la hora de manipular la máquina, utilice un método que se ajuste al peso de la máquina y a la situación para garantizar la seguridad.

Para cargar o descargar la máquina de un remolque, utilice una rampa adecuada. Amarre bien la máquina para garantizar la seguridad durante el transporte.

DEFINICIÓN DE LOS PICTOGRAMAS



Advertencia

Peligro

Advertencia

Guarde las distancias de seguridad.

Advertencia

Herramientas giratorias

Advertencia

Consulte el manual de usuario y retire la bujía antes de realizar cualquier intervención.

Advertencia

Lea el manual de instrucciones

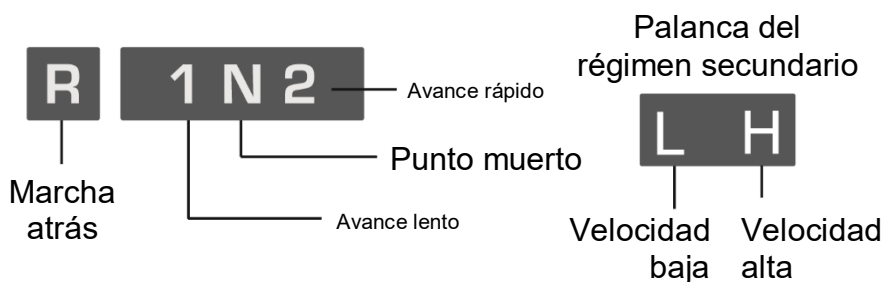

Control del acelerador | Botón de parada

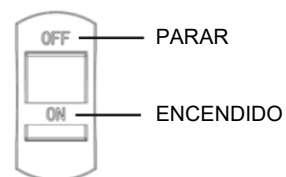

Utilice auriculares.

protectores

INFORMACIÓN TÉCNICA

	TF545P
Anchura de trabajo, mm	1100
Profundidad de trabajo, mm	150 - 300
Motor	WM177F/P
Carburante	Gasolina
Capacidad del depósito de combustible, litros	6,0
Capacidad del depósito de aceite, litros	1,10
Cilindrada, cm ³	270
Potencia máxima, CV (kW) a rpm	8,16 (6,0) a 3600
Marchas	H, L, R, N, 2, 1
Capacidad de aceite de la caja de cambios, litros	2,00
Peso bruto, kg	145
Peso neto, kg	130
Tamaño del embalaje, mm	1030x690x850

IMPORTANTE: Cuando la vida útil de este producto haya terminado y ya no se utilice, debe devolverse al distribuidor o a unas instalaciones de reciclaje adecuadas.

IMPORTANTE: Nos reservamos el derecho a modificar las especificaciones y diseños sin previo aviso para implementar mejoras. Tenga en cuenta que no se pueden realizar reclamaciones legales válidas en base a la información de este manual. Utilice solo piezas originales para las reparaciones. La garantía no es válida si no se utilizan piezas originales.

DESEMBALAJE/MONTAJE

Nota: El fabricante aplica una estrategia de mejora constante de sus productos; debido a ello, establece que este manual no tiene carácter contractual y se reserva el derecho a modificar las especificaciones de sus máquinas sin previo aviso.



Desembalaje



ADVERTENCIA:
Preste atención para no cortar los cables ni arañar la pintura de la máquina al cortar los bordes de la caja.

Ref.	Contenido de la caja
A	Piezas del motor
B	Soporte secundario 1°
C	Parte principal del soporte
D	Cubierta inferior
E	Barra de arrastre
F	Cubierta de las cuchillas
G	Soporte del. para la cubierta de las cuchillas
H	Palanca de cambio
I	Cuchillas
J	Rueda
K	Articulación de conexión
L	Cubierta de extensión
M	Cubierta lateral
N	Palanca de bloqueo
O	Soporte tras. de la cubierta de las cuchillas.
P	Soporte del cable de goma
Q	Placa de conexión
R	Bolsa de tornillería sólo para fresas
S	Bolsa de tornillería
T	Bolsa de herramientas



Montaje



Si el montaje de esta motoazada no se efectúa correctamente, pueden producirse lesiones graves. Siga todas las instrucciones escrupulosamente.

1 2 3 Montaje de las fresas de las 4 5 6 cuchillas.

Las ilustraciones solo muestran el montaje de las fresas de las cuchillas del lado derecho. Asegúrese de que los bordes afilados miran hacia un lado tanto en las cuchillas del lado derecho como en las del izquierdo.
Nota: Preste atención para distinguir el soporte secundario 1° y el soporte secundario 2°

7 Montaje de la articulación de conexión.

8 Montaje de la barra de arrastre.

9 Montaje del manillar.

10 11 Ajuste de la posición del manillar.

12 Montaje del control del embrague.

Gire hacia el lado correcto y apriete el perno.

13 14 Montaje de la cubierta inferior.

1. Coloque los cables,
2. Ponga en el soporte de goma correctamente,
3. Coloque la tapa y asegúrela con el perno.

15 16 Montaje de la cubierta de las 17 18 cuchillas.

19 No apriete el perno inmediatamente después de la instalación. Instale los 4 pernos y tuercas primero y luego apriételes uno por uno.

20 Montaje de la palanca de cambio.

21 Montaje de toma de fuerza para accesorios.



ADVERTENCIA:
Después de montar la máquina por completo, apriete todos los pernos y los tornillos con moderación: no los apriete en exceso.

Nota: Encomiende las labores de desmontaje siempre a un taller Husqvarna.



Descripción de los componentes

- 1- Motor
- 2- Cubierta de las cuchillas
- 3- Asa
- 4- Cubierta de extensión
- 5- Cuchillas
- 6- Barra de arrastre
- 7- Cubierta superior
- 8- Palanca de cambio
- 9- Parachoques
- 1- Control del embrague
- 11- Control del acelerador
- 12- Control de marcha atrás
- 13- Cubierta lateral
- 14- Cubierta inferior



Placa de identificación



Rueda de transporte

Cambie las cuchillas por las ruedas para el transporte.

ARRANQUE DE LA MÁQUINA



Agregue aceite de motor y compruebe el nivel



Agregue aceite para la caja de cambios



Agregue combustible
Recomendamos USAR un octanaje superior a 90



Abra la llave de combustible



Ponga el estrangulador en la posición A



Control del acelerador
Ponga la palanca en:



Coloque el interruptor de encendido/apagado en la posición de Encendido



Palanca de cambio
Ponga la palanca en la marcha N.



Tire del asa de la cuerda de arranque



ADVERTENCIA:
Cuando la máquina arranque, permanezca dentro de la zona de seguridad.



Ponga el estrangulador en la posición B

USO



— Adelante



Es esencial soltar la palanca de embrague antes de utilizar la marcha atrás



Habilite una zona de seguridad con un radio de 20 m alrededor de la máquina



— Marcha atrás



Es esencial soltar la palanca de embrague antes de utilizar la marcha atrás



Habilite una zona de seguridad con un radio de 20 m alrededor de la máquina



El uso de la marcha atrás es peligroso. Asegúrese de que no hay obstáculos detrás de usted y disminuya el régimen del motor antes de acoplar el embrague



— Dirección de funcionamiento de la motoazada con accesorios y control de cambios

PARADA



— Parada de los implementos

Suelte la palanca de embrague.



— Ponga la palanca de cambios en •N•



— Desacelere

Coloque el acelerador en:



— Parada del motor

Coloque el interruptor de encendido/apagado en la posición de APAGADO



— Cierre de la llave de combustible

TABLA DE MANTENIMIENTO

Comprobación diaria

Antes de arrancar el motor, compruebe los siguientes puntos.

- Los pernos o las tuercas no deben estar flojos ni rotos.



- Limpieza del elemento del filtro de aire



No utilice disolventes inflamables para limpiar el elemento de espuma del filtro de aire.



- Comprobación del nivel de aceite lubricante

- No debe haber fugas de combustible ni de lubricante.



- Debe haber suficiente combustible

- Mantenga la máquina limpia.

- Protección medioambiental.

- No hay vibraciones anormales ni ruido excesivo.

Después de las primeras 20 horas de cada mes

- Cambie el lubricante. Aceite del motor y caja de cambios.

Cada 50 horas de cada 3 meses

- Limpie el filtro de aire* (2 en la figura 4.6).

Cada 100 horas o cada 6 meses

- Limpie el filtro de combustible.
- Cambie el lubricante. Aceite del motor y caja de cambios.
- Limpie la bujía.
- Limpie el sombrerete de la bujía.

Cada 300 horas o una vez al año

- Sustituya el filtro de aire *.
- Compruebe el juego de la válvula **.
- Cambie la bujía.
- Limpie el filtro de combustible * *.
- Limpie la cámara de combustión * *.
- Compruebe el circuito de combustible * *.

* Limpie con más frecuencia si la máquina se utiliza en entornos polvorientos con partículas en suspensión.

** No se trata de una operación esencial a menos que haya problemas de rendimiento (debe encomendarse a un taller Husqvarna).



DECLARACIÓN CE DE CONFORMIDAD



Para la siguiente maquinaria

Nombre de producto: Motoazadas de gasolina
Nombre comercial: N/P
Función: motoazadas (sin ruedas motrices)
Tipo: Gasolina
Nº de modelo: TF545P
Nº de serie:

Por la presente se confirma que cumple todas las disposiciones pertinentes de la

Directiva relativa a las máquinas (2006/42/CE)

y que cumple con las normas armonizadas indicadas a continuación:

EN 709: 1997 + A4: 2009
EN 709: 1997 + A4/AC: 2012

Por la presente se confirma que cumple todas las disposiciones pertinentes de la

Directiva sobre compatibilidad electromagnética (2014/30/UE)

y que cumple con las normas armonizadas indicadas a continuación:

EN ISO 14982: 2009

Responsable de esta declaración:

Nombre del fabricante : Husqvarna AB
Dirección del fabricante : SE-561 82 HUSKVARNA SUECIA

Persona responsable de compilar las fichas técnicas establecidas en la UE

Nombre, apellidos : Husqvarna AB
Dirección : SE-561 82 HUSKVARNA SUECIA

Persona responsable de esta declaración:

Nombre, apellidos : Claes Losdal
Cargo/título : Director de I+D
Lugar : Huskvarna
Fecha : 22-12-2017



Husqvarna®

(Sello de la empresa y firma legal)

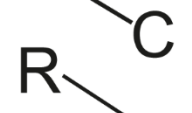
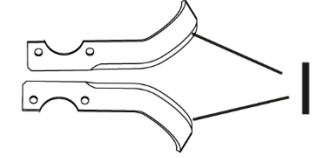
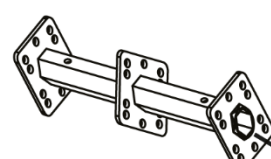
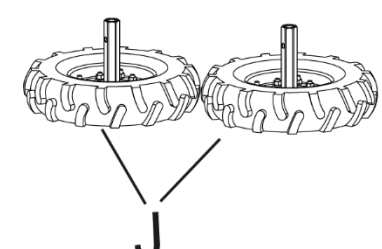
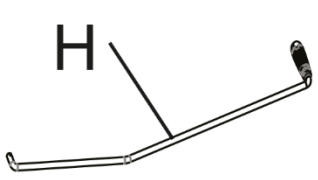
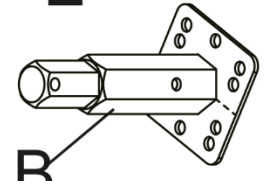
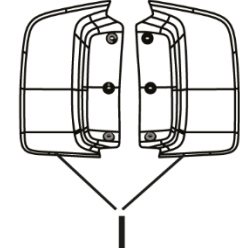
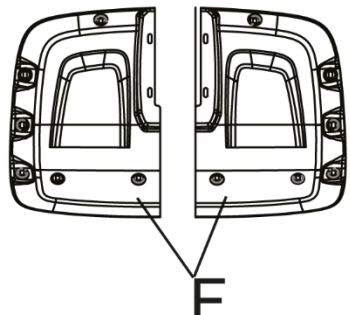
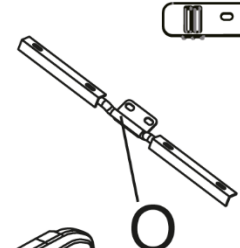
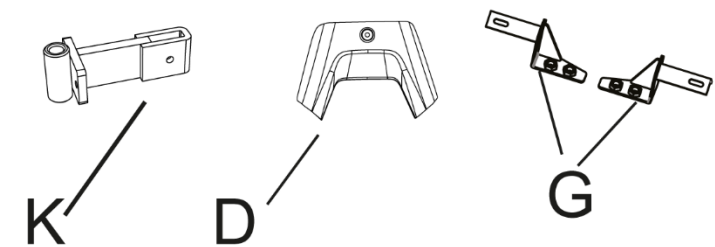
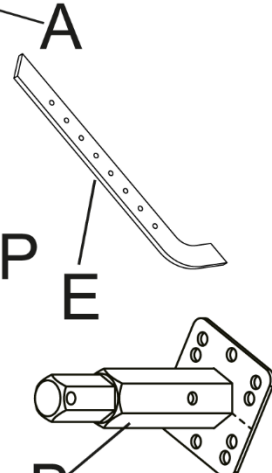
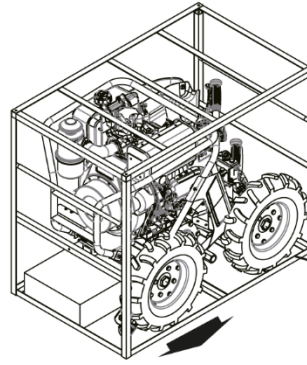
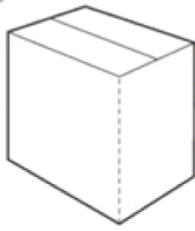

- ① X17
- ② X4
- ③ X4
- ④ X4
- ⑤ X23
- ⑥ X6
- ⑦ X2
- ⑧ X4
- ⑨ X16
- ⑩ X10
- ⑪ X2
- ⑫ X6

- Somente para dentes
- ⑩ X2
 - ⑬ X2
 - ⑭ X2
 - ⑮ X2
 - ⑯ X32
 - ⑰ X32
 - ⑱ X32

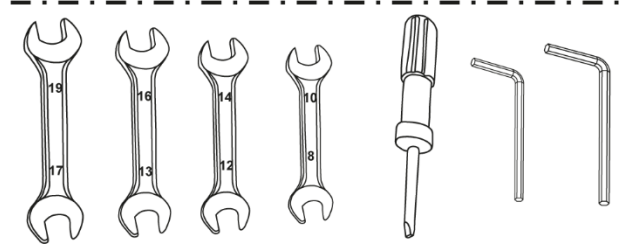

S

T

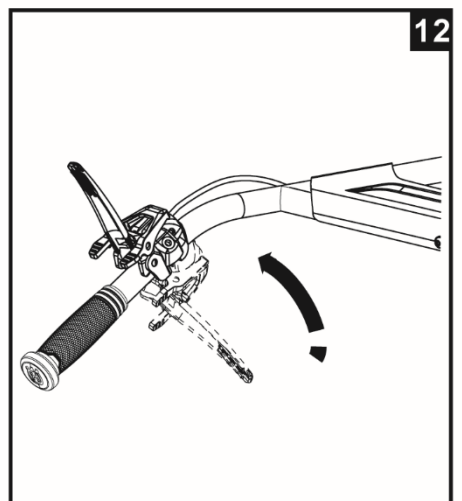
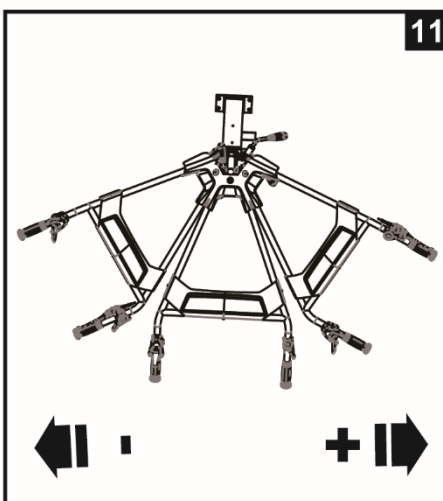
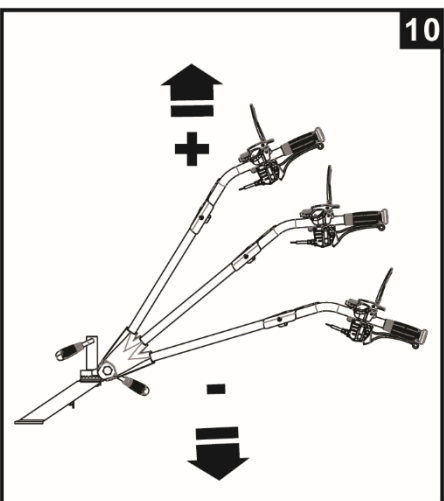
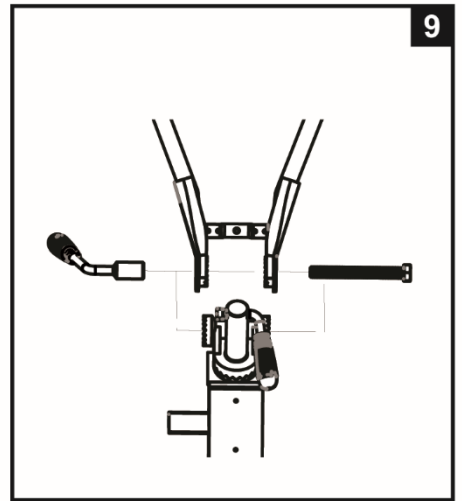
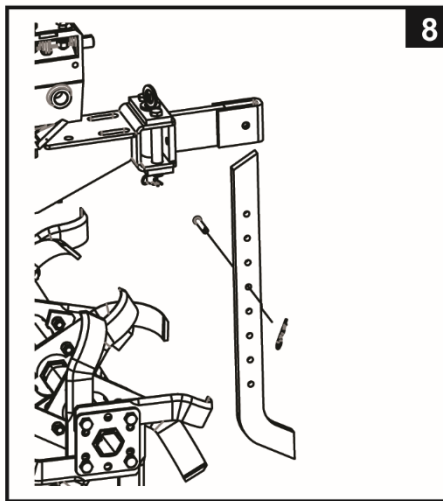
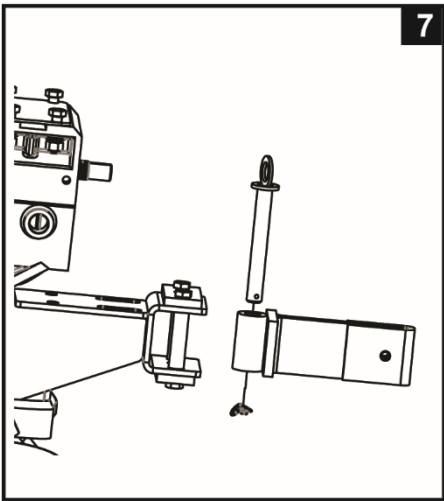
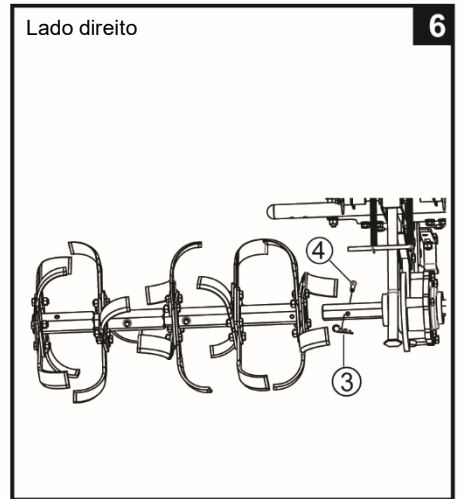
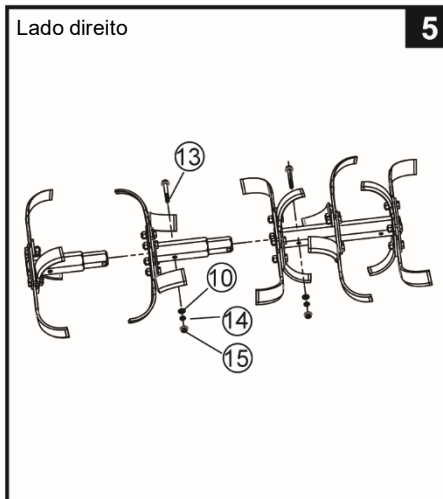
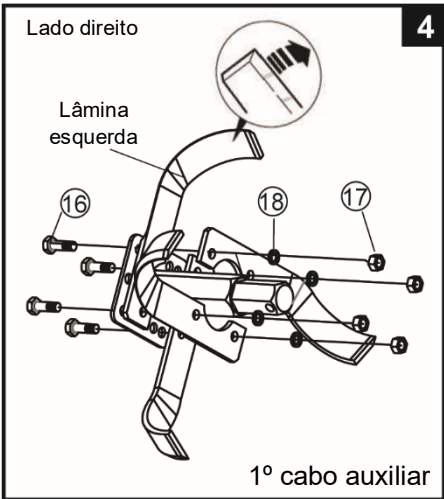
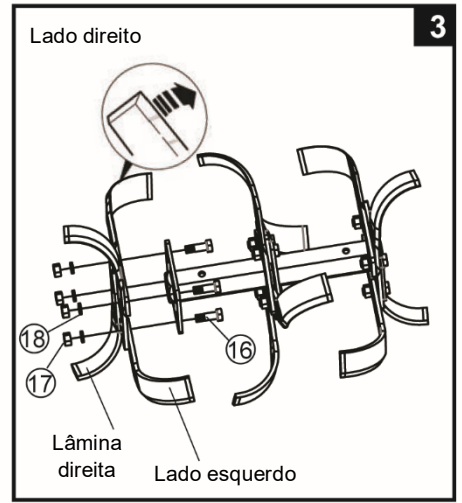
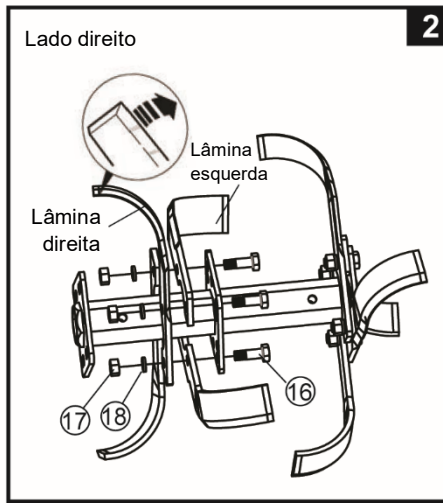
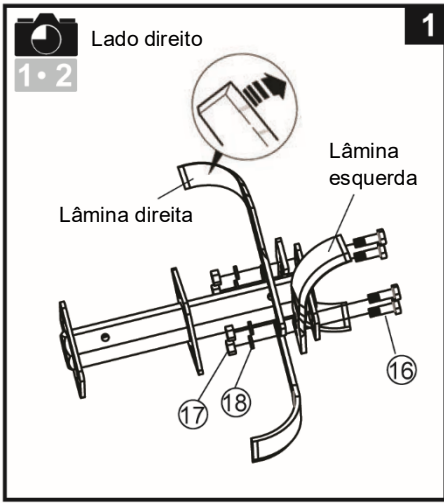

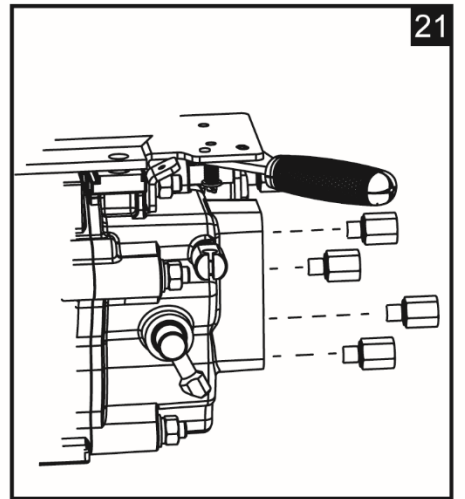
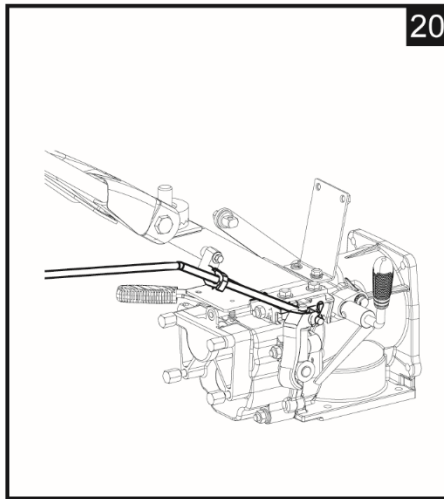
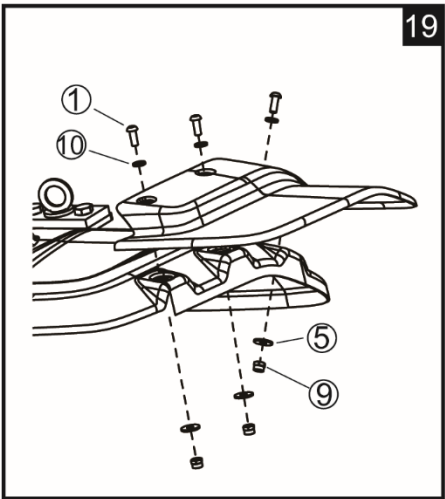
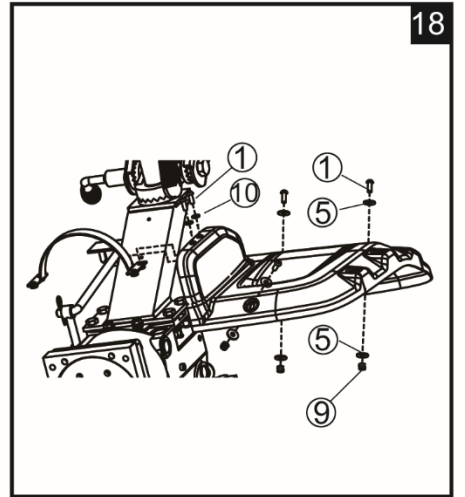
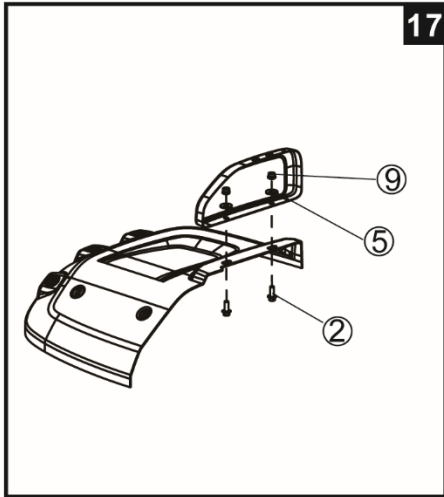
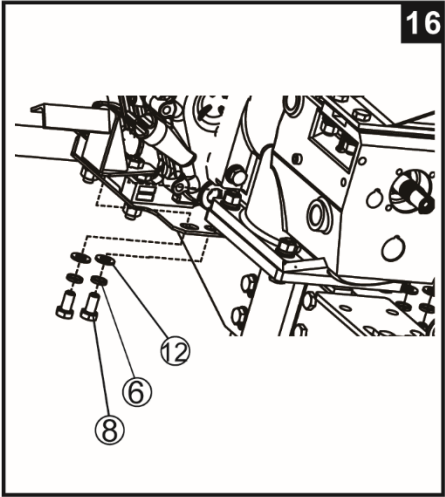
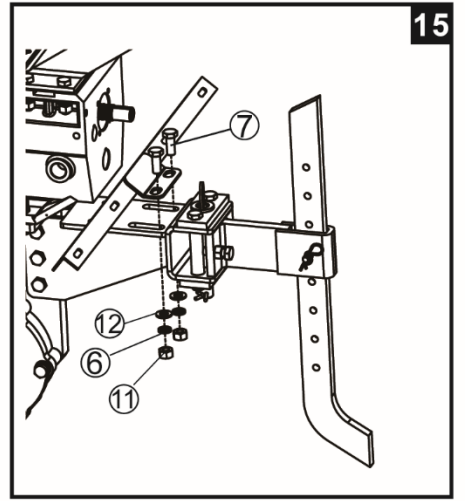
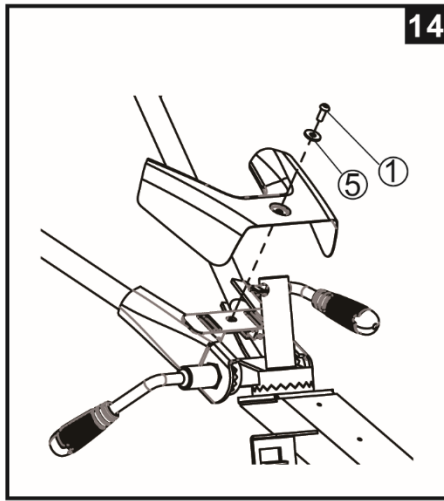
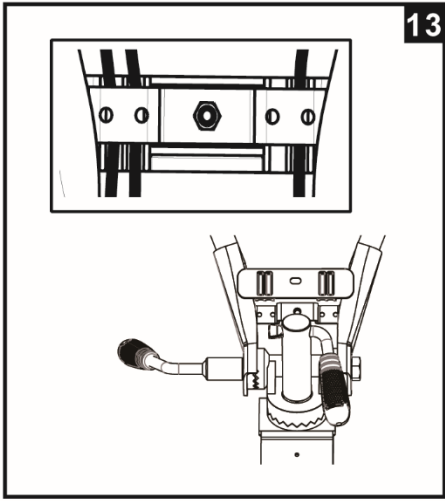



1-3

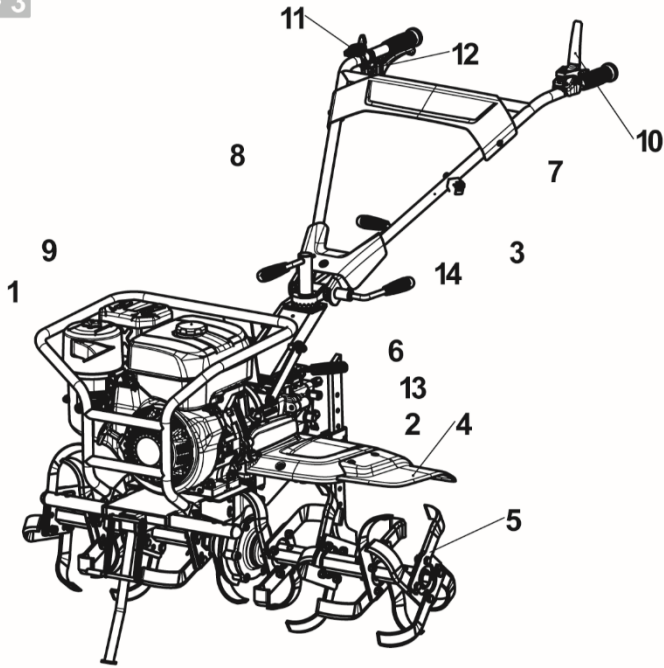

1-4

Husqvarna® Ano de prod.

Nº de série

Artigo n.º

Modelo

Escopo de trabalho

Profundidade de trabalho

Alavanca de câmbio

Deslocamento do motor

Qualidade de óleo do motor

Capacidade de óleo do motor

Qualidade de óleo da caixa de câmbio

Capacidade de óleo da caixa de câmbio

Potência nominal

Peso líquido

Combustível (octano/cetano)

HUSQVARNA AB
SE-561 82 HUSQVARNA
SUÉCIA

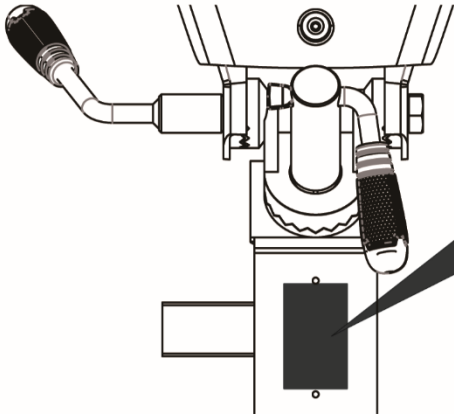

1-5

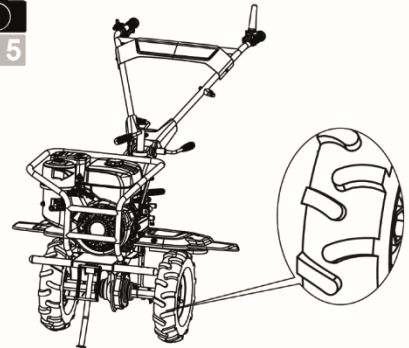

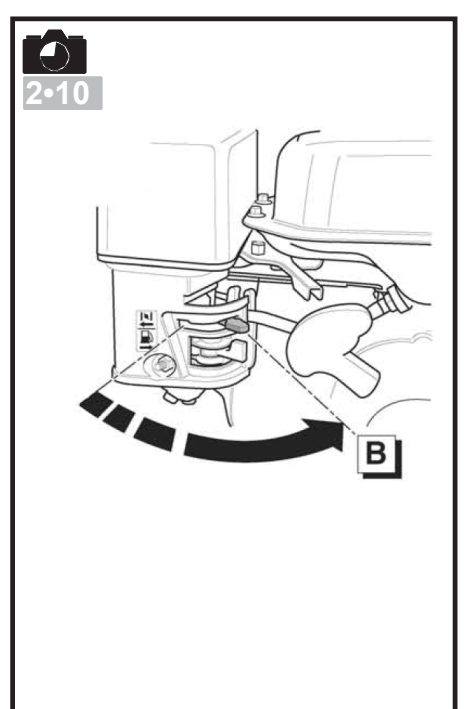
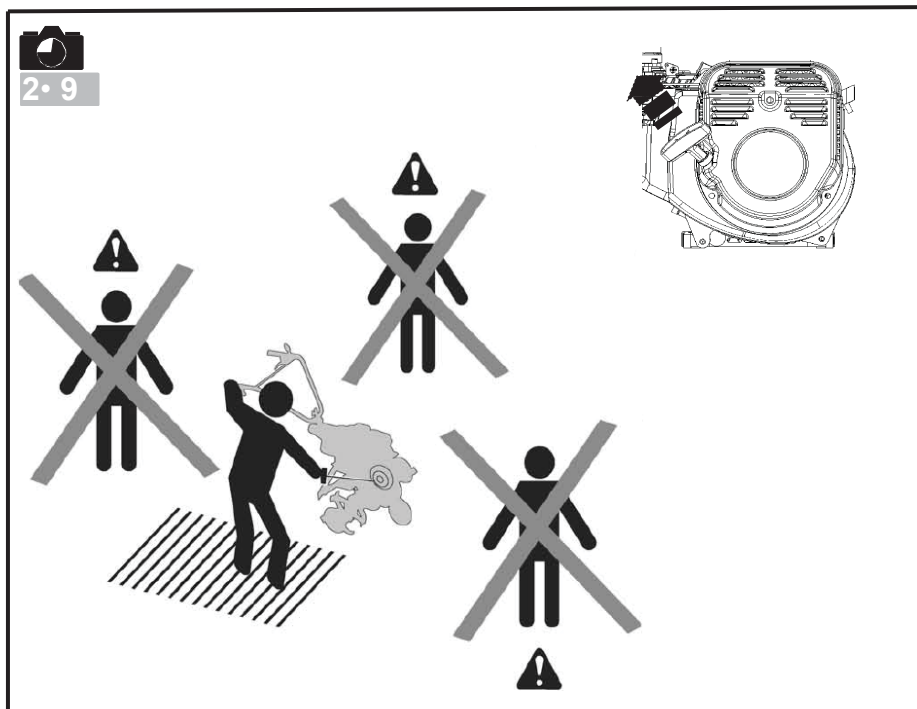
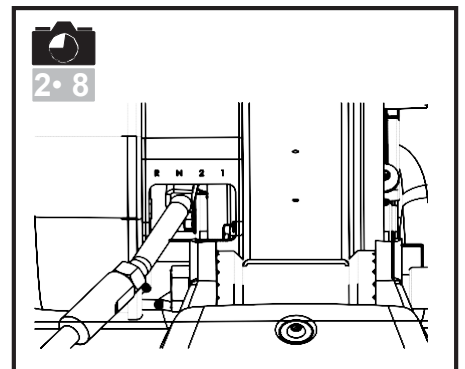
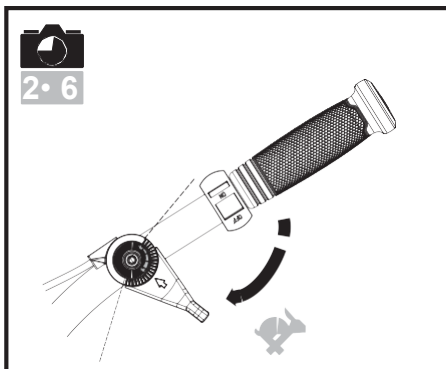
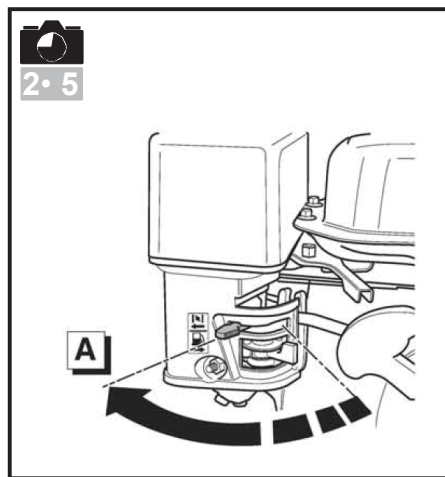
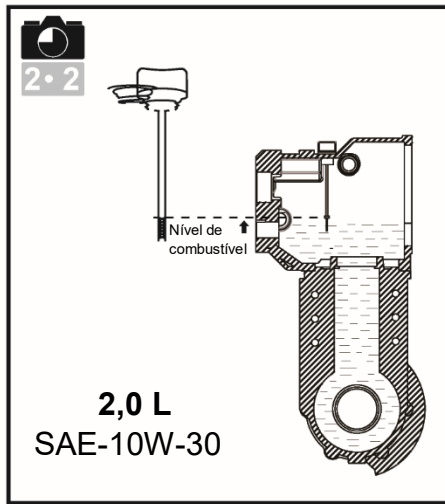
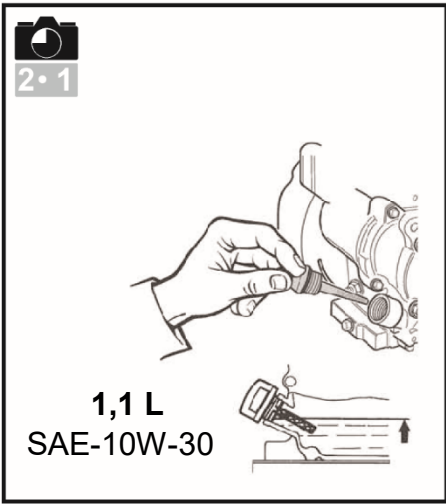



3•1

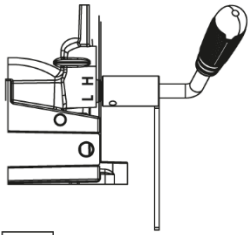

1 → H

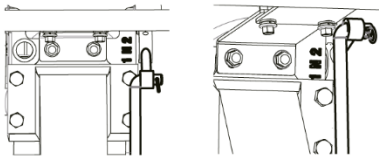

2 → 1,2

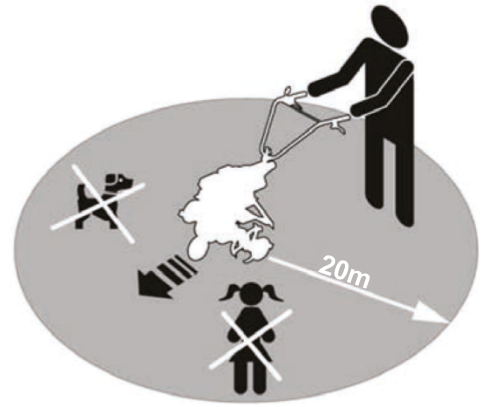
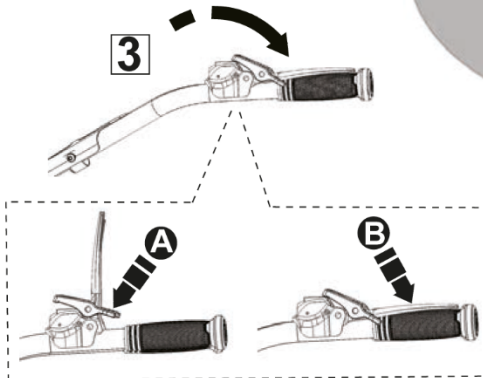

3•2

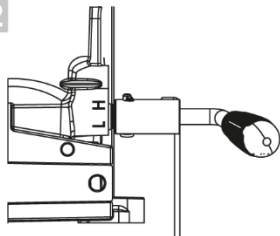

1 → L

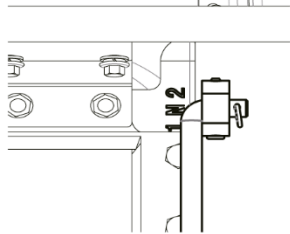

2 → N

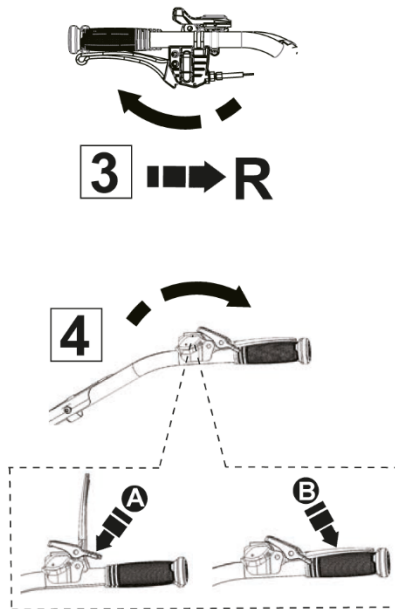

3•3

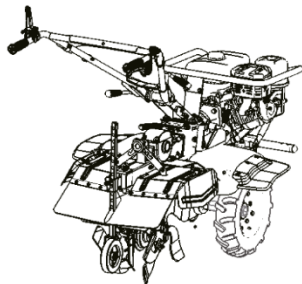

Valetadeira

1 → L
2 → 1,2
3 → A,B

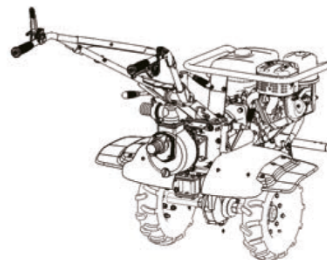

Bomba

1 → H
2 → N
3 → A,B

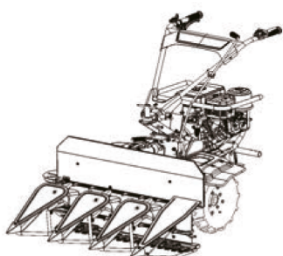

Motocultivador

1 → L
2 → N
3 → R
4 → A,B

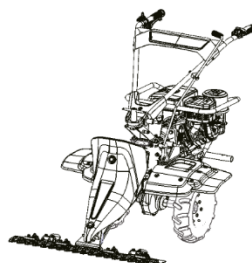

Cortador de grama

1 → L
2 → N
3 → R
4 → A,B

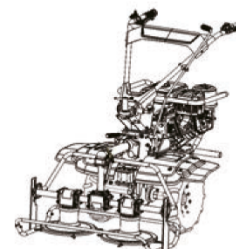

Cortador

1 → L
2 → N
3 → R
4 → A,B

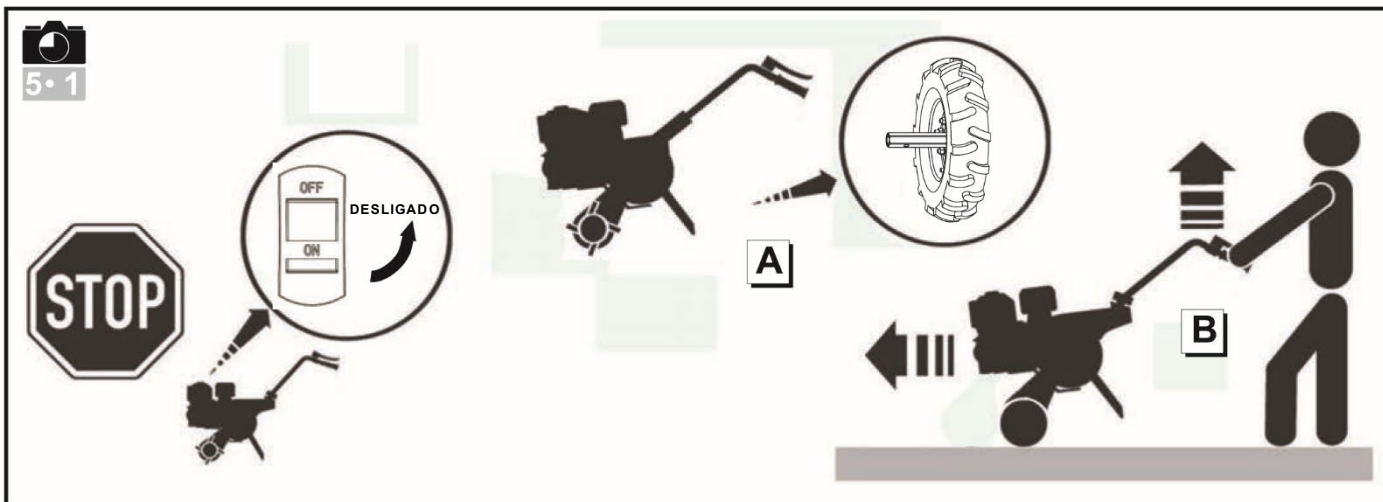
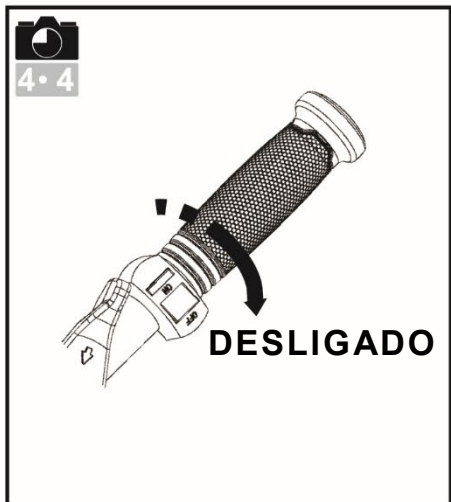
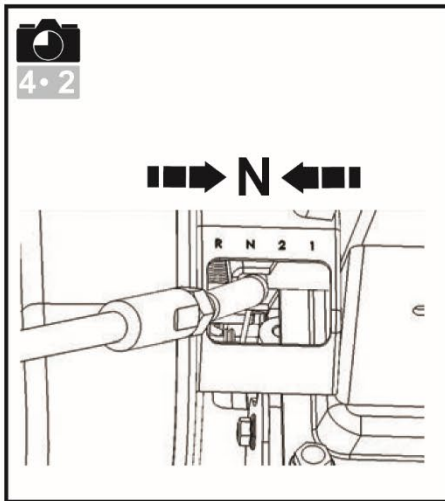
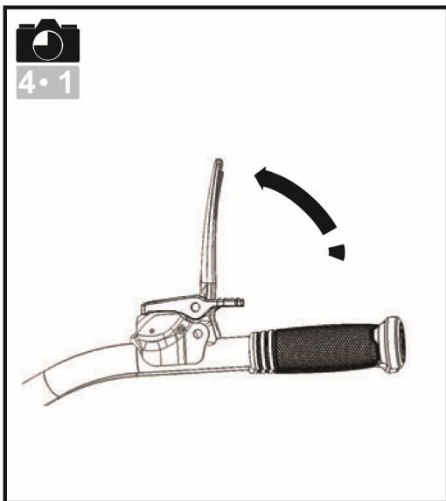

PRECAUÇÕES DE SEGURANÇA

Preste especial atenção às seções com as seguintes indicações:



PERIGO: Indica grande probabilidade de lesões graves ou até mesmo ferimentos mortais se as instruções não forem seguidas.

AVISO: Indica risco de lesão ou danos aos equipamentos se as instruções não forem seguidas.

OBSERVAÇÃO: Indica informações úteis.



Este símbolo é um lembrete para cui-dado com determinadas operações.

Em caso de problemas ou dúvidas sobre o motocultivador, entre em contato com o revendedor Husqvarna.



PERIGO: A máquina foi concebida para operação segura e confiável se utilizada conforme as instruções. Antes de utilizar a máquina, é importante entender o conteúdo deste manual. Caso contrário, há risco de lesões pessoais e danos ao equipamento.

Treinamento/informações

Familiarize-se com o uso e os controles corretos antes de utilizar a máquina. Saiba como desligar o motor rapidamente.

Use a máquina sempre de acordo com as recomendações contidas no manual do operador.

Lembre-se de que o usuário é responsável por quaisquer acidentes ou ações perigosas que afetem outras pessoas ou seus pertences. O usuário é responsável por avaliar os possíveis riscos do solo a ser trabalhado e portomar todas as precauções necessárias para garantir a segurança, especialmente em declives e sobre solos soltos, escorregadios e desnivelados.

Nunca permita que crianças ou pessoas não familiarizadas com estas instruções utilizem a máquina. Podem existir leis locais que definam uma idade mínima para os usuários.

Nunca trabalhe com a máquina quando houver pessoas, especialmente crianças, ou animais dentro de um raio de 20 metros da máquina; o operador deve permanecer necessariamente nos controles dos punhos de comando.

Não use a máquina caso esteja utilizando medicamentos ou outras substâncias que possam retardar suas reações ou causar sonolência.

Preste especial atenção em terrenos de solo rígido, pois a máquina tende a ficar muito menos estável do que em solos cultivados.

Use sempre calçados resistentes e antiderrapantes e calças compridas e justas durante as operações. Não use a máquina com os pés descalços ou vestindo chinelos. Recomenda-se usar protetores auriculares.

Use a máquina para o propósito de fabricação, ou seja, o preparo de solos

Preparação

Inspecione cuidadosamente a área onde a máquina será utilizada e remova quaisquer objetos que possam ser arremessados pela máquina (pedras, arames, vidros, objetos metálicos...).

Antes do uso, inspecione sempre a máquina para assegurar que as ferramentas não estejam desgastadas ou danificadas. Substitua peças desgastadas ou danificadas.

Mantenha em bom estado os cabos elétricos que desligam o motor, para ter certeza de que o motor foi desligado.

Confirme a ausência de vazamentos de combustível ou óleo.

Não use a máquina sem protetores e capas e verifique o perfeito encaixe de todas as conexões.

Uso

Nunca transporte pessoas na máquina.

Tenha cuidado ao ligar o motor. Para tal, siga as instruções do fabricante e mantenha os pés afastados das lâminas.

Desligue o motor quando a máquina não estiver em uso.

Ao segurar a máquina, caminhe e não corra.

Preste muita atenção ao empurrar a máquina na sua direção ou inverter o sentido de rotação (se desejado).

Mantenha uma distância de segurança das lâminas giratórias, definida pelo comprimento da coluna de direção.

Não coloque as mãos ou os pés próximos ou embaixo de peças rotativas.

O motor e o sistema de escapamento ficam muito quentes durante a operação. Há risco de lesões por queimadura em caso de contato.

Em caso de:

- vibração anormal;
- obstrução;
- problema ao engatar ou desengatar a embreagem;
- colisão com corpo estranho;
- deterioração do cabo de parada do motor

Desligue o motor imediatamente (caso o cabo de parada do motor esteja danificado, use o controle de ignição para desligar o motor, conforme descrito no parágrafo "ignição do motor"), espere o resfriamento da máquina, desconecte o fio da vela de ignição, inspecione a máquina e, antes de usá-la novamente, solicite os reparos necessários realizados por uma oficina Husqvarna.

Trabalhe somente sob a luz do dia ou com boa iluminação artificial.

Não use a máquina em declives superiores a 20°.

Em declives, trabalhe em curvas diagonais. Não suba nem desça diretamente nenhum declive.

Em terrenos em declive, mantenha os pés sobre o solo. Tenha cuidado do mudar de direção.

O uso de acessórios diferentes dos recomendados pode tornar a máquina perigosa e causar danos à máquina que não serão cobertos pela garantia.

Manutenção/armazenamento

Desligue o motor antes de efetuar limpeza, inspeções, ajustes ou manutenção na máquina ou substituir as peças.

Ao substituir peças, desligue o motor e use luvas grossas.

Para garantir segurança na utilização, mantenha todas as porcas e parafusos apertados.

Para reduzir risco de incêndio, mantenha o motor, o silenciador e a área de armazenamento de

combustível livres de plantas, óleo usado ou qualquer outro material inflamável.

Caso o silenciador do escapamento esteja com defeito, solicite sua substituição por uma oficina Husqvarna.

Não conserte peças; substitua-as pelas sobressalentes específicas do fabricante.

Substitua as lâminas em conjuntos completos para mantê-las girando de forma balanceada.

Para sua própria segurança, não altere as características da máquina. Não altere as configurações de rotação do motor e não use o motor em rotações excessivas. Manutenções regulares são essenciais para a segurança e para manter o nível de desempenho.

Deixe o motor resfriar antes de guardar a máquina.

Perigo! O combustível é altamente inflamável!

Armazene o combustível em recipientes especialmente projetados para tal. Encha o tanque sempre em ambientes externos e não fume durante o abastecimento.

Não desrosqueie a tampa do depósito nem complete o tanque com combustível enquanto o motor estiver em operação ou ainda estiver quente.

Em caso de vazamento de combustível no solo, não tente ligar o motor. Leve a máquina para outro local e evite chamas abertas.

Guarde a máquina em local seco. Nunca guarde a máquina em recintos onde a máquina possa entrar em contato com chamas, faíscas ou fontes de calor intensas.

Recoloque corretamente as tampas do depósito de combustível e do recipiente de combustível.

Para reduzir vazamentos, limite a quantidade de combustível no tanque.

Não opere o motor em espaços confinados onde possa ocorrer acúmulo de vapor de monóxido de carbono.

O monóxido de carbono pode ser fatal. Garanta uma boa ventilação.

Deslocamento, manuseio, transporte

Qualquer ação na máquina que não seja a escavação do solo deve ser realizada com o motor desligado,

exceto quando (escavação de solo) a máquina tiver de ser deslocada com o uso da roda de transporte, conforme descrito no capítulo "Deslocamento".

Manuseio: não tente erguer a máquina. O peso da máquina é indicado na etiqueta de tipo no meio deste manual. Para garantir a segurança, utilize um método de manuseio adaptado ao peso da máquina e à situação.

Ao carregar ou descarregar a máquina em ou de um reboque, utilize uma rampa adequada. Amarre a máquina corretamente para transportá-la com segurança.

DEFINIÇÃO DOS PICTOGRAMAS



Aviso
Perigo

Aviso
Mantenha a distância de segurança

Aviso
Peças rotativas

Aviso
Consulte o Manual do Operador e remova a vela de ignição antes de efetuar qualquer serviço

Aviso
Leia o Manual do Operador

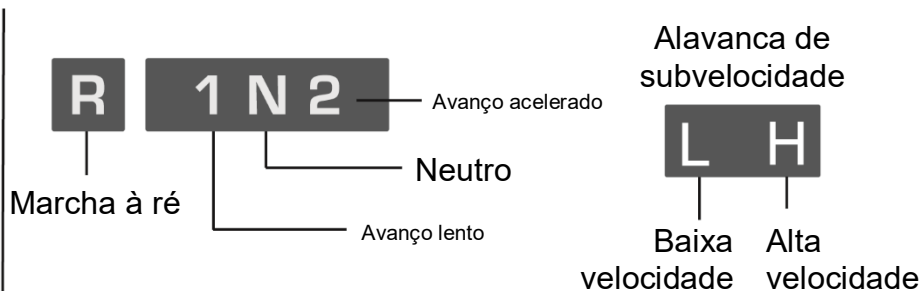

Acelerador | Interruptor de parada

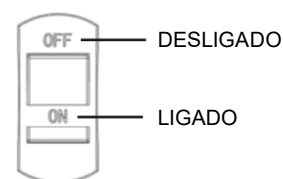

Use protetor auricular.

INFORMAÇÕES TÉCNICAS

	TF545P
Largura de preparação do solo, mm	1100
Profundidade de preparação do solo, mm	150 - 300
Motor	WM177F/P
Combustível	Gasolina
Capacidade do depósito de combustível, litros	6,0
Capacidade do tanque de óleo, litros	1,10
Cilindrada, cm ³	270
Potência máx. hp (kW) a rpm	8,16 (6,0) a 3600
Marchas	H, L, R, N, 2, 1
Capacidade de óleo da caixa de engrenagem, litros	2,00
Peso bruto, kg	145
Peso líquido, kg	130
Dimensões da embalagem, mm	1030x690x850

IMPORTANTE! Ao atingir a vida útil deste produto e este não for mais utilizado, devolva-o ao distribuidor ou leve-o a uma usina de reciclagem.

IMPORTANTE! Reservamo-nos o direito de alterar as especificações e o projeto sem prévia notificação, de modo a implementar melhorias. Nenhuma reivindicação judicial terá validade com base em informações fornecidas neste manual. Em caso de reparos, use apenas peças originais. A garantia não terá validade se forem utilizadas peças não originais.

REMOÇÃO DA EMBALAGEM/MONTAGEM

Observação: No constante desejo de melhorar os produtos, o fabricante determina que este manual não é contratual e reserva-se o direito de modificar as especificações das máquinas sem prévia notificação.



Remoção da embalagem



AVISO:
Cuidado para não cortar os cabos ou arranhar a pintura da máquina ao abrir as extremidades da caixa.

Ref.	Conteúdo da embalagem
A	Peças do motor
B	Cabo auxiliar - 1º
C	Suporte de compensação principal
D	Tampa protetora inferior
E	Barra de arrasto
F	Capa dos dentes
G	Suporte capa dos dentes FR.
H	Alavanca de câmbio
I	Lâminas
J	Roda
K	Junta de conexão
L	Tampa de extensão
M	Tampa lateral
N	Alça de bloqueio
O	Suporte capa dos dentes RR.
P	Suporte do cabo de borracha
Q	Placa de conexão
R	Somente dentes da bolsa de acessórios
S	Bolsa de acessórios
T	Bolsa de ferramentas



Montagem



AVISO:
A montagem incorreta deste motocultivador giratório pode causar graves lesões. Siga todas as instruções atentamente.



Encaixe das lâminas dos dentes.

As ilustrações mostram apenas a montagem das lâminas dos dentes do lado direito.

As bordas afiadas devem ficar viradas para o mesmo lado nos dentes das laterais direita e esquerda.

Observação: Preste atenção ao diferenciar o 1º cabo auxiliar e o 2º cabo auxiliar.

7 Encaixe da junta de conexão.

8 Encaixe da barra de arrasto.

9 Encaixe da barra de apoio.

10 11 Ajuste da posição da barra de apoio.

12 Encaixe do controle de embreagem.

Gire para o lado correto e aperte o parafuso.

13 14 Encaixe da tampa protetora inferior.

1. Organize os cabos,
2. Coloque corretamente a capa de borracha,
3. Coloque a tampa e aperte com o parafuso.

15 16 Encaixe da capa dos dentes.

17 18 Não aperte o parafuso imediatamente depois de instalado. Primeiro, instale os quatro parafusos e porcas; depois, aperte-os um por um.

20 Encaixe da alavanca de câmbio.

21 Montagem da PTO para acessórios.



AVISO:

Depois de montar a máquina por completo, aperte todos os parafusos com moderação: não os aperte excessivamente.

Observação: Qualquer operação de desmonte somente deve ser realizada por uma oficina da Husqvarna.



Descrição dos componentes

- 1- Motor
- 2- Capa dos dentes
- 3- Alça
- 4- Tampa de extensão
- 5- Lâminas
- 6- Barra de arrasto
- 7- Tampa protetora superior
- 8- Alavanca de câmbio
- 9- Para-choque
- 1- Controle da embreagem
- 11- Acelerador
- 12- Controle de marcha à ré
- 13- Tampa lateral
- 14- Tampa protetora inferior



Etiqueta de tipo



Roda de transporte

Durante o transporte, troque as lâminas por rodas

COMO LIGAR A MÁQUINA



Abasteça com óleo de motor e verifique o nível



Abasteça com óleo de engrenagem



Complete com gasolina
Recomenda-se USAR um valor de octanas superior a 90



Abra a torneira de combustível



Ajuste o afogador na posição A



Acelerador
Coloque a alavanca em:



Coloque o interruptor lig/desl na posição ON (ligar)



Alavanca de câmbio
Coloque a alavanca na marcha N.



Puxe o punho de arranque



AVISO:

Ao ligar a máquina, mantenha-se na zona de segurança.



Ajuste o afogador na posição B

USO



— Avançar



É essencial desengatar a embreagem antes de utilizar a marcha à ré.



Mantenha uma zona de segurança com 20 m de raio em volta da máquina.



— Marcha à ré



É essencial desengatar a embreagem antes de utilizar a marcha à ré.



Mantenha uma zona de segurança com 20 m de raio em volta da máquina.



O uso da marcha à ré é perigoso. Certifique-se da ausência de obstáculos atrás do operador e reduza a rotação do motor antes de engatar a embreagem



— Sentido de operação do motocultivador com acessórios e controle de engrenagem

PARADA



— Pare as peças rotativas

Solte a alavanca da embreagem.



— Coloque a alavanca de câmbio em •N•



— Reduza o acelerador

Coloque o acelerador em:



— Desligar o motor

Coloque o interruptor lig/desl na posição OFF (desligar)



— Feche a torneira de combustível

TABELA DE MANUTENÇÃO

Verificação diária

Antes de ligar o motor, verifique os seguintes pontos:

- Não pode haver porcas ou parafusos frouxos ou danificados.



- Limpeza do elemento do filtro de ar



Não use solvente inflamável para limpar o elemento do filtro de ar de espuma.



- Verifique o nível do óleo lubrificante

- Ausência de vazamento de gasolina ou óleo lub.



- Gasolina suficiente

- Mantenha a máquina limpa.
- Proteção do meio ambiente.
- Ausência de vibrações anormais ou ruído excessivo.

Após as primeiras 20 horas de cada mês

- Troque o óleo lubrificante do motor e da caixa de câmbio.

A cada 50 horas ou a cada 3 meses

- Limpe o filtro de ar * (2 Fig. 4.6).

A cada 100 horas ou a cada 6 meses

- Limpe o filtro de combustível.
- Troque o óleo lubrificante do motor e da caixa de câmbio.
- Limpe a vela de ignição.
- Limpe a cobertura da vela de ignição.

A cada 300 horas ou uma vez por ano

- Substitua o filtro de ar *.
- Verifique a folga na válvula * *.
- Substitua a vela de ignição.
- Limpe o filtro de combustível * *.
- Limpe a câmara de combustão * *.
- Verifique o circuito de combustível * *.

* Limpe com mais frequência em condições de uso em que o ar contenha poeira ou resíduos suspensos.

** Não essencial, exceto em casos de problemas de desempenho (a ser realizado por uma oficina Husqvarna).



DECLARAÇÃO DE CONFORMIDADE DA CE



Para as seguintes máquinas

Nome do produto: Motocultivadoras movidas a gasolina
Nome comercial: N/A
Função: motocultivadoras (sem rodas acionadas)
Tipo: Gasolina
Modelo nº: TF545P
Nº de série:

confirma-se aqui a conformidade com todas as disposições relevantes da

Diretiva de Máquinas (2006/42/CE)

e a conformidade com as normas harmonizadas

EN 709: 1997 + A4: 2009
EN 709: 1997 + A4/AC:2012

confirma-se aqui a conformidade com todas as disposições relevantes da

Diretiva de Compatibilidade Eletromagnética (2014/30/UE)

e a conformidade com as normas harmonizadas:

EN ISO 14982: 2009

O responsável por esta declaração é o

Nome do fabricante : Husqvarna AB
Endereço do fabricante : SE-561 82 HUSKVARNA SUÉCIA

Pessoa responsável pela compilação dos arquivos técnicos estabelecidos na UE

Nome, sobrenome : Husqvarna AB
Endereço : SE-561 82 HUSKVARNA SUÉCIA

Pessoa responsável por esta declaração

Nome, sobrenome : Claes Losdal
Posição/cargo : Diretor de pesquisa e desenvolvimento
Local : Huskvarna
Data : 22/12/2017



Husqvarna

(Carimbo da empresa e assinatura legal)

www.husqvarna.com

Original instructions
Instrucciones originales
Instruções originais
1158791-26

2019-04-18