



 **Husqvarna**<sup>®</sup>



**322HD60**

---

## Contents

---

Introduction.....	2	Troubleshooting.....	12
Safety.....	3	Transportation, storage and disposal.....	13
Operation.....	7	Technical data.....	13
Maintenance.....	9	EC Declaration of Conformity.....	15

---

## Introduction

---

### Product overview

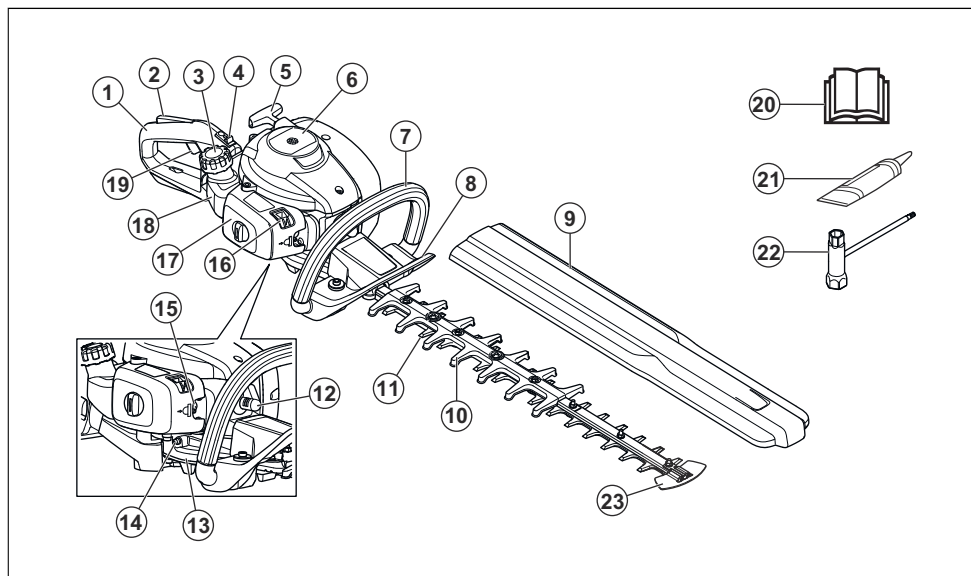

1. Rear handle
2. Throttle trigger lockout
3. Fuel tank cap
4. Stop switch
5. Starter rope handle
6. Cylinder cover
7. Front handle
8. Hand guard
9. Transport guard
10. Blade guard
11. Blade
12. Spark plug cap and spark plug
13. Gear housing
14. Grease nipple
15. Air purge bulb
16. Choke control
17. Air filter cover

18. Fuel tank
19. Throttle trigger
20. Operator's manual
21. Tube of grease
22. Combination wrench
23. Blade tip protection

### Product description

The product is a hedge trimmer with a combustion engine.

### Intended use

Use the product to cut branches and twigs. Do not use the product for other tasks.

## Symbols on the product



**WARNING!** This product is dangerous. Injury or death can occur to the operator or bystanders if the product is not used carefully and correctly. To prevent injury to the operator or bystanders, read and obey all safety instructions in the operator's manual.



Read the operator's manual carefully and make sure that you understand the instructions before use.



Use approved hearing protection and approved eye protection.



Use approved protective gloves.



Use heavy-duty slip-resistant boots.



Noise emission to the environment refer to the European Community's Directive. The emission of the product is specified in the Technical data chapter and on the label.



The product agrees with the applicable EC directives.

yyyyywwxxxx

The rating plate shows serial number. **yyyyy** is the production year and **ww** is the production week.

**Note:** Other symbols/decals on the product refer to certification requirements for some markets.

## EU V



**WARNING:** Tampering with the engine voids the EU type-approval of this product.

## Safety

### Safety definitions

Warnings, cautions and notes are used to point out specially important parts of the manual.



**WARNING:** Used if there is a risk of injury or death for the operator or bystanders if the instructions in the manual are not obeyed.



**CAUTION:** Used if there is a risk of damage to the product, other materials or the adjacent area if the instructions in the manual are not obeyed.

**Note:** Used to give more information that is necessary in a given situation.

### General safety instructions



**WARNING:** Read the warning instructions that follow before you use the product.

- Incorrect or careless use of a hedge trimmer can turn it into a dangerous tool that can cause serious or even fatal injury. It is extremely important that you read and understand the contents of this operator's manual.
- This product produces an electromagnetic field during operation. This field may under some circumstances interfere with active or passive medical implants. To reduce the risk of serious or fatal injury, we recommend persons with medical implants to consult their physician and the medical implant manufacturer before operating this product.
- Overexposure to vibration can lead to circulatory damage or nerve damage in people who have impaired circulation. Contact your doctor if you experience symptoms of overexposure to vibration. Such symptoms include numbness, loss of feeling, tingling, pricking, pain, loss of strength, changes in skin color or condition. These symptoms normally appear in the fingers, hands or wrists. The risk increases at low temperatures.
- If you encounter a situation where you are uncertain how to proceed you should ask an expert. Contact your dealer or your service workshop. Avoid all usage which you consider to be beyond your capability.
- Keep in mind that the operator is responsible for accidents or hazards occurring to other people or their property.
- Never allow anyone else to use the product without first ensuring that they have understood the contents of the operator's manual.
- Never allow children to use or be in the vicinity of the product. As the product is equipped with a

springloaded stop switch and can be started by low speed and force on the starter handle, even small children under some circumstances can produce the force necessary to start the product. This can mean a risk of serious personal injury. Therefore remove the spark plug cap when the product is not under close supervision.

- Store the product out of reach of children.
- Never use the product if you are tired, if you have drunk alcohol, or if you are taking medication that could affect your vision, your judgement or your co-ordination.
- Never use a product that is faulty. Carry out the checks, maintenance and service instructions described in this manual. Some maintenance and service measures must be carried out by trained and qualified specialists. Refer to instructions under the heading Maintenance.
- Never use a product that has been modified in any way from its original specification.

## Safety instructions for operation



**WARNING:** Read the warning instructions that follow before you use the product.

- Never use the product in extreme weather conditions such as severe cold, very hot and/or humid climates.
- Faulty blades can increase the risk of accidents.
- Ensure that no-one comes closer than 15 m / 50 ft while you are working.
- Observe your surroundings and make sure that there is no risk of people or animals coming into contact with the cutting equipment.
- Inspect the working area. Remove any objects that could be thrown out.
- Always ensure you have a safe and stable working position.
- Never leave the product unsupervised with the motor running.
- Make sure that your hands and feet do not come near the cutting unit when the engine is running.
- If anything jams in the blades while you are working, switch off the engine and wait until it has stopped completely before cleaning the blades. Disconnect the HT lead from the spark plug. Refer to *To examine the blades on page 12*.
- When the engine is switched off, keep your hands and feet away from the cutting unit until it has stopped completely.
- Watch out for stumps of branches that can be thrown out during cutting.
- Listen out for warning signals or shouts when you are wearing hearing protection. Always remove your hearing protection as soon as the engine stops.
- Never work from a ladder, stool or any other raised position that is not fully secured.

- Always use both hands to hold the product. Hold the product in front of your body.
- If any foreign object is hit or if vibrations occur stop the product immediately. Disconnect the HT lead from the spark plug. Check that the product is not damaged. Repair any damage.
- Ensure that the spark plug cap and ignition lead are undamaged to avoid the risk of electric shock.
- Check that all nuts and screws are tight.
- Make sure the gear housing is lubricated correctly. Refer to *To lubricate the gear housing on page 11*.
- The gear housing gets hot when the product has been in use. To avoid burning yourself do not touch the gear housing.
- All covers and guards must be fitted before starting.
- The transport guard should always be fitted to the cutting unit when the product is not in use.

## Personal protective equipment



**WARNING:** Read the warning instructions that follow before you use the product.

- Always use approved personal protective equipment when you use the product. Personal protective equipment cannot fully prevent injury but it decreases the degree of injury if an accident does occur. Let your dealer help you select the right equipment.
- Use approved hearing protection that provides adequate noise reduction. Long-term exposure to noise can result in permanent hearing impairment.
- Use approved eye protection. If you use a visor, you must also use approved protective goggles. Approved protective goggles must comply with the ANSI Z87.1 standard in the USAs or EN 166 in EU countries.

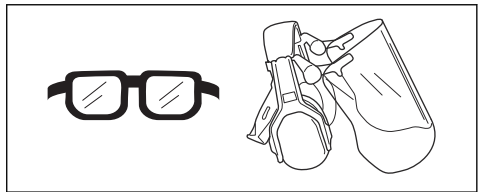

- Use gloves when necessary, for example when you attach, examine or clean the cutting equipment.

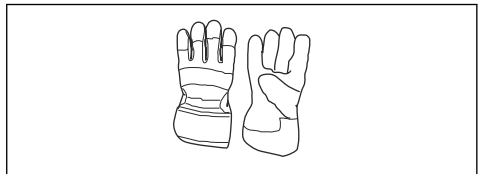

- Use sturdy non-slip boots or shoes.

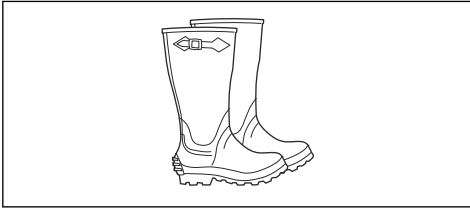

- Use clothing made of a strong fabric. Always use heavy, long pants and long sleeves. Do not use loose clothing that can catch on twigs and branches. Do not wear jewelry, short pants, sandals or go with bare feet. Put your hair up safely above shoulder level.
- Keep first aid equipment close at hand.



### Safety devices on the product



**WARNING:** Read the warning instructions that follow before you use the product.

- Do not use a product with defective safety devices.
- Do a check of the safety devices regularly. If the safety devices are defective, speak to your Husqvarna service agent.

### To do a check of the throttle trigger lockout

1. Make sure that the throttle trigger lockout (A) and throttle trigger (B) move freely and that the return spring operates correctly.

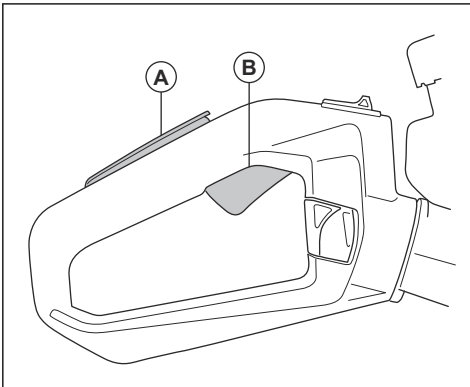

2. Push down the throttle trigger lockout and make sure that it goes back to its initial position when you release it.

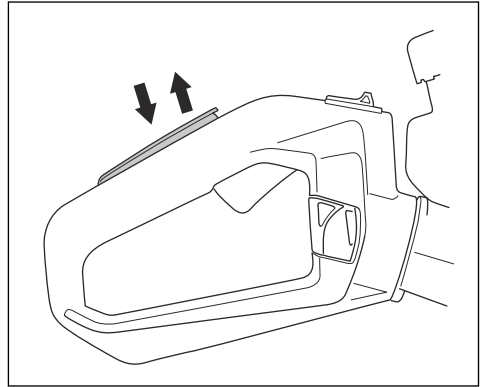

3. Release the throttle trigger lockout and make sure that the throttle trigger is locked at idle speed position.

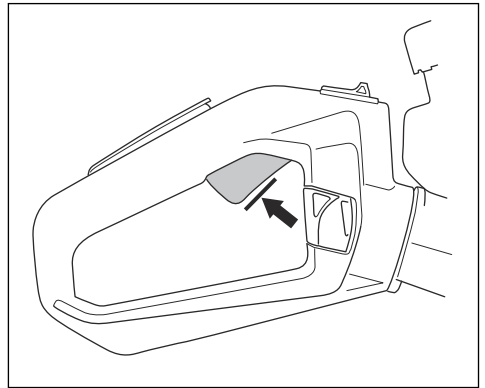

4. Start the engine and apply full throttle.
5. Release the throttle trigger and make sure that the blades stop fully.



**WARNING:** If the blades move when the throttle trigger is in the idle speed position, adjust the idle speed. Refer to *To adjust the idle speed on page 10.*

### To do a check of the stop switch

1. Start the engine.
2. Push the stop switch to the stop position and make sure that the engine stops.



**WARNING:** The stop switch automatically goes back to start position. To prevent accidental start, remove the spark plug cap from the spark plug when you assemble or do maintenance on the product.

### To do a check of the hand guard

The hand guard prevents injuries from the blades.

1. Stop the engine.
2. Make sure that the hand guard is attached correctly.
3. Examine the hand guard for damages.

### To do a check of the vibration damping system

The vibration damping system decreases vibration in the handles. The vibration damping units operate as a separation between the product body and the handle unit.

1. Do a visual check for deformation and damage.
2. Make sure that the vibration damping units are correctly attached.

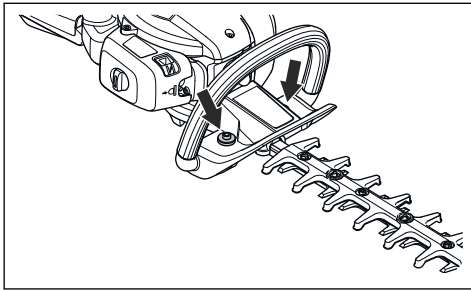

### To do a check of the muffler



**WARNING:** Do not operate the product without a muffler or a defective muffler. A defective muffler can increase the noise level and the risk of fire. Do not use the product without, or with a broken, spark arrester screen. The spark arrester screen must be replaced if it is damaged.



**WARNING:** The mufflers become very hot during and after operation, also at idle speed.



**CAUTION:** If the spark arrester screen is frequently blocked it can be a sign that performance of the catalytic converter is decreased. Turn to your servicing dealer to examine the muffler. A blocked spark arrester screen will cause overheating and result in damage to the cylinder and piston.



**WARNING:** The inner surfaces of the muffler contain chemicals that can cause cancer. Be careful not to touch these elements if the muffler is damaged.

The muffler keeps the noise levels to a minimum and points the exhaust fumes away from the operator. A

muffler with a catalytic converter decrease harmful exhaust gases.

1. Stop the engine.
2. Do a visual check for damage and deformation.
3. Make sure that the muffler is correctly attached to the product.
4. Clean the spark arrester screen with a wire brush.

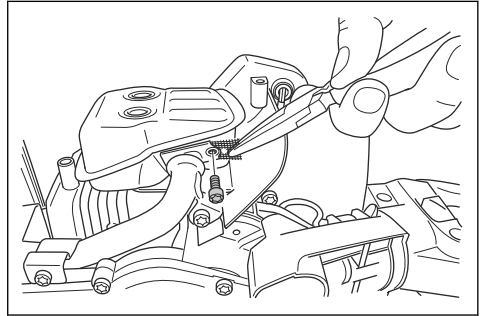

### To do a check of the blades and blade guard

The outer part of the blades has the function of a blade guard. The blade guard prevents cut injuries.

1. Stop the engine and make sure that the blades stop.
2. Remove the spark plug cap from the spark plug.
3. Put on protective gloves.
4. Make sure that the blade and blade guard is not damaged or bent. Always replace a damaged or bent blade, or a damaged blade guard.
5. Make sure that the screws to the blades and blade guard are tight.

### Fuel safety



**WARNING:** Read the warning instructions that follow before you use the product.

- Do not start the product if there is fuel or engine oil on the product. Remove the unwanted fuel/oil and let the product dry.
- If you spill fuel on your clothing, change clothing immediately.
- Do not get fuel on your body, it can cause injury. If you get fuel on your body, use soap and water to remove the fuel.
- Do not start the product if the engine has a leak. Examine the engine for leaks regularly.
- Be careful with fuel. Fuel is flammable and the fumes are explosive and can cause injuries or death.
- Do not breathe in the fuel fumes, it can cause injury. Make sure that there is a sufficient airflow.
- Do not smoke near the fuel or the engine.
- Do not put warm objects near the fuel or the engine.

- Do not add the fuel when the engine is on.
- Make sure that the engine is cool before you refuel.
- Before you refuel, open the fuel tank cap slowly and release the pressure carefully.
- Do not add fuel to the engine in an indoor area. Not sufficient airflow can cause injury or death because of asphyxiation or carbon monoxide.
- Tighten the fuel tank cap fully. If the fuel tank cap is not tightened, there is a risk of fire.
- Move the product a minimum of 3 m / 10 ft from the position where you filled the tank before a start.
- Do not fill the fuel tank fully. Heat causes the fuel to expand. Keep a space at the top of the fuel tank.

## Safety instructions for maintenance



**WARNING:** Read the warning instructions that follow before you use the product.

- Stop the engine and make sure that the cutting equipment stops. Let the product become cool before you do the maintenance.

- Disconnect the spark plug cap before you do the maintenance.
- The exhaust fumes from the engine contain carbon monoxide, an odourless, poisonous and very dangerous gas that can cause death. Do not run the product indoors or in closed spaces.
- The exhaust fumes from the engine are hot and can contain sparks. Do not run the product indoors or near flammable material.
- Accessories and changes to the product that are not approved by the manufacturer, can cause serious injury or death. Do not change the product. Always use original accessories.
- If the maintenance is not done correctly and regularly, there is an increased risk of injury and damage to the product.
- Only do the maintenance as this operator's manual recommends. Let an approved Husqvarna service agent do all other servicing.
- Let an approved Husqvarna service agent do servicing on the product regularly.
- Replace damaged, worn or broken parts.

## Operation

### Introduction



**WARNING:** Read and understand the safety chapter before you use the product.

### Fuel

This product has a two-stroke engine.



**CAUTION:** Incorrect type of fuel can result in engine damage. Use a mixture of gasoline and two-stroke oil.

### Premixed fuel

- Use Husqvarna premixed alkylate fuel of a good quality, for best performance and extension of the engine life. This fuel contains less harmful chemicals compared to regular fuel, which decreases harmful exhaust fumes. The quantity of remains after combustion is lower with this fuel, which keeps the components of the engine more clean.

### To mix fuel

#### Gasoline

- Use good quality unleaded gasoline with a maximum of 10% ethanol contents.



**CAUTION:** Do not use gasoline with an octane grade less than 90 RON/87 AKI. Use of a lower octane grade can cause

engine knocking, which causes engine damages.

- We recommend that you use gasoline of a higher octane grade for work with continuously high rpm.

#### Two-stroke oil

- For best results and performance use Husqvarna two-stroke oil.
- If Husqvarna two-stroke oil is not available, use a two-stroke oil of good quality for air-cooled engines. Speak to your servicing dealer to select the correct oil.



**CAUTION:** Do not use two-stroke oil for water-cooled outboard engines, also referred to as outboard oil. Do not use oil for four-stroke engines.

#### To mix gasoline and two-stroke oil

Gasoline, liter	Two-stroke oil, liter
	<b>2% (50:1)</b>
5	0.10
10	0.20
15	0.30
20	0.40



**CAUTION:** Small errors can influence the ratio of the mixture drastically when you mix small quantities of fuel. Measure the quantity of oil carefully and make sure that you get the correct mixture.

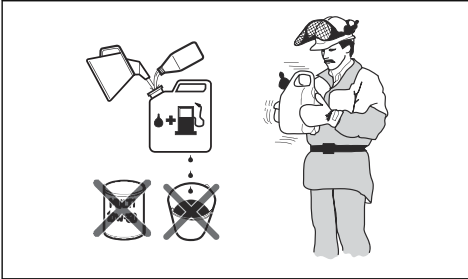

1. Fill half the quantity of gasoline in a clean container for fuel.
2. Add the full quantity of oil.
3. Shake the fuel mixture.
4. Add the remaining quantity of gasoline to the container.
5. Carefully shake the fuel mixture.



**CAUTION:** Do not mix fuel for more than 1 month at a time.

### To fill the fuel tank

1. Clean the area around the fuel tank cap.

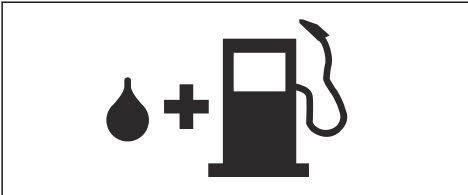

2. Shake the container and make sure that the fuel is fully mixed.
3. Tighten the fuel tank cap carefully.
4. Move the product 3 m/10 ft or more away from the refueling area and fuel source before starting.

**Note:** To see where the fuel tank is on your product, refer to *Introduction on page 2*.

### To adjust the handle

The rear handle can be adjusted into 3 positions.

- Release the handle lock and turn the handle.

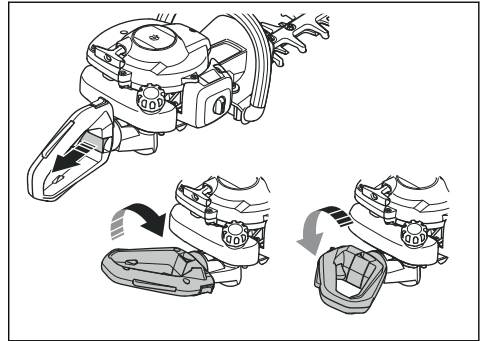

### To start the product with a cold engine

1. Pull the choke control to choke position.

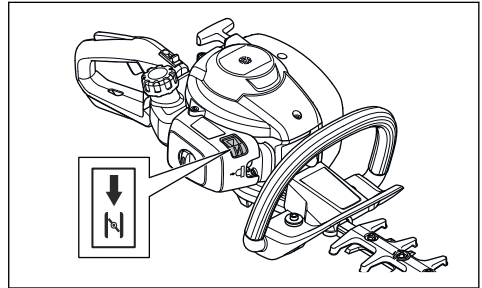

2. Push the air purge bulb approximately 6 times or until the bulb starts to fill with fuel. It is not necessary to fill the air purge bulb fully.
3. Hold the body of the product on the ground with your left hand. Do not step on the product.
4. Pull the starter rope handle slowly with your right hand until you feel some resistance, then pull the starter rope handle quickly and with force.



**WARNING:** Do not wind the starter rope around your hand.



**CAUTION:** Do not pull the starter rope to full extension and do not let go of the starter rope handle.

5. Continue to pull the starter rope handle until the engine fires, then push the choke control to its initial position.



**WARNING:** The blades move when the engine starts.

6. Continue to pull the starter rope handle until the engine starts.



7. Push and release the throttle trigger to set the engine to idle speed.
8. Push the throttle trigger gradually to increase the engine speed.
9. Make sure that the engine runs smoothly.

### To start the product with a warm engine

1. Hold the body of the product on the ground with your left hand. Do not step on the product.
2. Pull the starter rope handle slowly with your right hand until you feel some resistance, then pull the starter rope handle quickly and with force. Continue until the engine starts.

**Note:** For more information about how to start the product, refer to *To start the product with a cold engine* on page 8.

### To stop the product

- Move the stop switch to the stop position to stop the engine.



**CAUTION:** The stop switch automatically goes back to run position.

### To operate the product

1. Start near the ground and move the product up along the hedge when you cut the sides. Make sure that the body of the product does not touch the hedge.

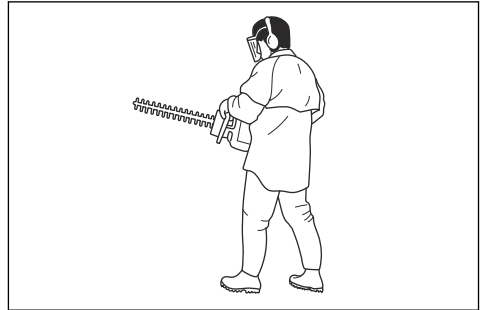

**WARNING:** Make sure that the front of the cutting equipment does not touch the ground.

2. Adjust the speed to align with the work load.
3. Hold the product near your body for a stable work position.
4. Be careful and operate the product slowly.

## Maintenance

### Introduction



**WARNING:** Read and understand the safety chapter before you do maintenance on the product.

### Maintenance schedule

Maintenance	Before operation	After 40 h	After 100 h
Clean the external surface.	After each operation.		
Clean the muffler, exhaust pipe and engine from leaves, dirt and unwanted lubricant.	After each operation.		
Make sure that the cutting unit does not move at idle speed.	X		
Do a check of the stop switch. Refer to <i>To do a check of the stop switch</i> on page 5.	X		
Examine the cutting unit for damages and cracks. Replace if it is damaged.	X		
Examine the hand guard for damages and cracks. Replace if it is damaged.	X		
Do a check of the throttle trigger lockout and the throttle trigger. Refer to <i>To do a check of the throttle trigger lockout</i> on page 5.	X		
Examine the engine, the fuel tank and the fuel hose for leaks.	X		

Maintenance	Before operation	After 40 h	After 100 h
Tighten nuts and screws.	X		
Examine the starter and the starter rope for damages.		X	
Do a check that the screws that hold the blades together are correctly tightened.		X	
Clean the air filter. Clean more frequently if used in areas which has dust. Replace if it is damaged.		X	
Examine the vibration damping units for damages and cracks. Replace if it is damaged.		X	
Clean the external surface of the spark plug and the area around it. Remove the spark plug and measure the electrode gap. Adjust the electrode gap or replace the spark plug. Refer to <i>To examine the spark plug on page 11</i> .		X	
Clean the cooling system.		X	
Clean the external surface of the carburetor and the area around it.		X	
Examine the fuel filter for contamination and the fuel hose for cracks and other defects. Replace if it is damaged.			X
Clean the spark arrester screen on the muffler, replace if it is damaged.			X
Clean the inner surface of the fuel tank.			X
Replace the spark plug.			X
Examine the clutch, clutch spring and the clutch drum for wear. Replace if it is damaged by an approved servicing dealer.			X
Make sure that the gear housing is filled with grease.			X
Do a check of all cables and connections.			X

## To adjust the idle speed

1. Clean the air filter and attach the air filter cover.
2. Start the product. Refer to *To start the product with a cold engine on page 8*.
3. Turn the idle adjustment screw T clockwise until the cutting unit starts to move.

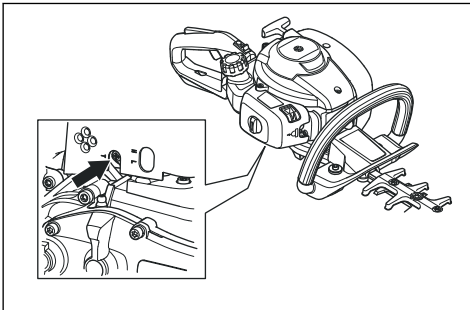

4. Turn the idle adjustment screw counterclockwise until the cutting unit stops.



**WARNING:** If the cutting unit does not stop when you adjust the idle speed, speak to your nearest servicing dealer. Do not use the product until it is correctly adjusted or repaired.

**Note:** The idle speed is correct when the engine operates smoothly in all positions. Refer to *Technical data on page 13* for the recommended idle speed.

## To clean the cooling system

The cooling system keeps the engine temperature down. The cooling system includes the cooling fins on

the cylinder, the cylinder cover and the air intake through the crankcase.

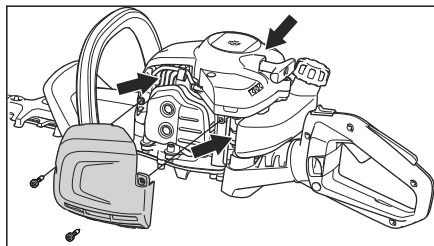

**CAUTION:** The air intake between the fuel tank and crankcase, is easily blocked by leaves. Clean the air intake fully.

1. Clean the cooling system with a brush weekly or more frequently if it is necessary.
2. Make sure that the cooling system is not dirty or blocked.

## To examine the spark plug



**CAUTION:** Always use the recommended spark plug type. Incorrect spark plug type can cause damage to the product.

- Examine the spark plug if the engine is low on power, is not easy to start or does not operate correctly at idle speed.
- To decrease the risk of unwanted material on the spark plug electrodes, obey these instructions:
  - a) Make sure that the idle speed is correctly adjusted.
  - b) Make sure that the fuel mixture is correct.
  - c) Make sure that the air filter is clean.
- If the spark plug is dirty, clean it and make sure that the electrode gap is correct, refer to *Technical data on page 13*.

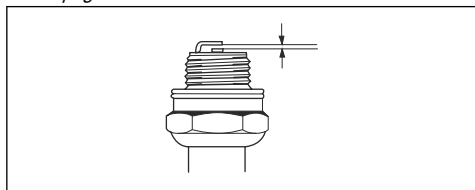

- Replace the spark plug if it is necessary.

## To clean the air filter

Clean the air filter regularly from dirt and dust. This prevents carburetor malfunctions, starting problems, loss of engine power, wear to engine parts and more fuel consumption than usual.

1. Remove the air filter cover (A).

2. Remove the filter (B) from the filter frame.

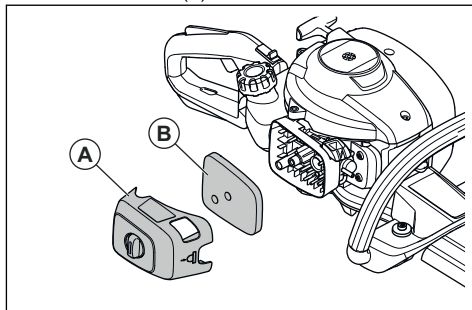

3. Clean the filter with warm soap water.

**Note:** An air filter that is used for a long time can not be fully cleaned. Replace the air filter regularly and always replace a defective air filter.

4. Make sure that the filter is dry.
5. Apply oil to the air filter. Refer to *To apply oil to the air filter on page 11*
6. Clean the inner surface of the air filter cover. Use compressed air or a brush.

## To apply oil to the air filter



**CAUTION:** Always use Husqvarna special air-filter oil. Do not use other types of oil.



**WARNING:** Put on protective gloves. The air-filter oil can cause skin irritation.

1. Put the air filter in a plastic bag.
2. Put the oil in the plastic bag.
3. Rub the plastic bag to supply the oil equally across the air filter.
4. Push the unwanted oil out of the air filter while in the plastic bag.

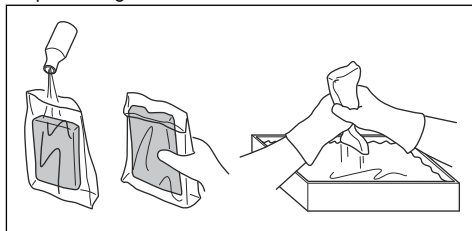

## To lubricate the gear housing

- Use Husqvarna special grease. Speak to your servicing dealer for more information about recommended grease.

- Add the grease through the grease nipple.

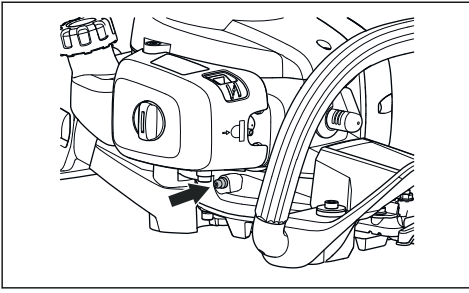

**CAUTION:** Do not fill the gear housing fully.

## To examine the blades

1. Remove the cap on the gear housing.
2. Make sure that the blades move freely. Put the combination wrench in the gear housing and turn clockwise and counterclockwise.

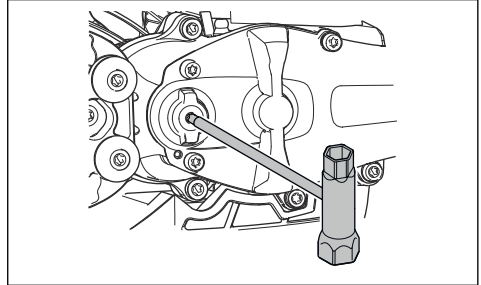

3. Examine the edges of the blades for damages and deformation.
4. Use a file to remove burrs on the blades.

## To clean and lubricate the blades

1. Clean the blades from unwanted materials before and after you use the product.
2. Lubricate the blades before long periods of storage.

**Note:** Speak to your servicing dealer for more information about recommended cleaning agents and lubricants.

# Troubleshooting

## Troubleshooting

The engine does not start		
Problem	Possible cause	Recommended step
Starter pawls	The starter pawls cannot move freely.	Adjust or replace the starter pawls.
		Clean around the starter pawls.
		Speak to an approved servicing dealer.
Fuel tank	Incorrect fuel type.	Drain it and use correct fuel.
Carburetor	Incorrect idle speed.	Adjust the idle speed.
No spark	The spark plug is dirty or wet.	Make sure that the spark plug is dry and clean.
	Incorrect electrode gap.	Clean the spark plug. Make sure that the electrode gap of the spark plug is correct. Make sure that the spark plug is installed with a suppressor.
		Refer to <i>Technical data on page 13</i> for correct electrode gap.
Spark plug	The spark plug is loose.	Tighten the spark plug.

<b>The engine starts but stops again</b>		
<b>Problem</b>	<b>Possible cause</b>	<b>Recommended step</b>
Fuel tank	Incorrect fuel type.	Drain it and use correct fuel.
Carburetor	Incorrect idle speed.	Adjust the idle speed. Refer to <i>To adjust the idle speed on page 10</i> . Speak to your servicing dealer if it is necessary.
Air filter	Clogged air filter.	Clean the air filter.

<b>Blade</b>		
<b>Problem</b>	<b>Possible causes</b>	<b>Recommended step</b>
The blade moves slowly or does not move.	The blade is blocked or it is damaged.	Clean the blades from unwanted materials. Refer to <i>To clean and lubricate the blades on page 12</i> . Remove burrs from the blade, refer to <i>To examine the blades on page 12</i> . Replace the blade if it is damaged.
The blade does not cut easily.	The blade is not sharp or it is damaged.	Sharpen the blade, refer to <i>To examine the blades on page 12</i> . Replace the blade if it is damaged.
The blade becomes hot.	There is friction between the blades.	Remove burrs from the blade and lubricate the blade. Refer to <i>To clean and lubricate the blades on page 12</i> .

---

## Transportation, storage and disposal

---

### Transportation and storage

- Always allow the product to cool down before storage.
- For storage and transportation of the product and fuel, make sure that there are no leaks or fumes. Sparks or open flames, for example from electrical devices or boilers, can start a fire.
- Always use approved containers for storage and transportation of fuel.
- Empty the fuel before transportation or before long-term storage. Discard the fuel at an applicable disposal location.

- Attach the transport guard during transportation and storage.
- Remove the spark plug cap from the spark plug.
- Attach the product during transportation. Make sure that it cannot move.
- Clean and do servicing on the product before long-term storage.

---

## Technical data

---

### Technical data

	<b>322HD60</b>
<b>Engine</b>	
Cylinder displacement, cm <sup>3</sup>	21.7

	<b>322HD60</b>
Idle speed, rpm	2900
Recommended max speed, rpm	9000
Maximum engine power acc. to ISO 8893, kW/hp @ rpm	0.6/0.8 @ 7800
Catalytic converter muffler	Yes
<b>Ignition system</b>	
Spark plug	HQT-4 672201
Electrode gap, mm	0.5
<b>Fuel</b>	
Fuel tank capacity, l/cm <sup>3</sup>	0.3/300
<b>Weight</b>	
Without fuel, kg	5.2
<b>Noise emissions</b> <sup>1</sup>	
Sound power level, measured dB (A)	100
Sound power level, guaranteed L <sub>WA</sub> dB (A)	101
<b>Sound levels</b> <sup>2</sup>	
Equivalent sound pressure level at the operator's ear, measured according to EN ISO 10517, dB(A)	92
<b>Vibration levels</b> <sup>3</sup>	
Equivalent vibration levels (a <sub>hw,eq</sub> ) at handles, measured according to EN ISO 10517, m/s <sup>2</sup> :	
Front/Rear, mm/s <sup>2</sup>	4.4/4.3
<b>Blades</b>	
Type	Double sided
Cutting length, mm	600
Cutting speed, cuts/min	4400

<sup>1</sup> Noise emissions in the environment measured as sound power (L<sub>WA</sub>) in conformity with EC directive 2000/14/EC. Reported sound power level for the product has been measured with the original cutting attachment that gives the highest level. The difference between guaranteed and measured sound power is that the guaranteed sound power also includes dispersion in the measurement result and the variations between different products of the same model according to Directive 2000/14/EC.

<sup>2</sup> Reported data for noise pressure level has a typical statistical dispersion (standard deviation) of 1 dB (A).

<sup>3</sup> Reported data for vibration level has a typical statistical dispersion (standard deviation) of 1 m/s<sup>2</sup>.

---

# EC Declaration of Conformity

---

## EC Declaration of Conformity

**Husqvarna AB**, SE-561 82 Huskvarna, Sweden, tel: +46-36-146500, declares that the hedge trimmers **Husqvarna 322HD60** with serial numbers dating from 2019 onwards (the year is clearly stated on the rating plate, followed by the serial number), comply with the requirements of the COUNCIL'S DIRECTIVE:

- of May 17, 2006 "relating to machinery" **2006/42/EC**
- of February 26, 2014 "relating to electromagnetic compatibility" **2014/30/EU**
- of May 8, 2000 "relating to the noise emissions in the environment" **2000/14/EC**. Conformity assessment according to Annex V. For information relating to noise emissions, refer to the Technical data chapter.
- of June 8, 2011 "on the restriction of the use of certain hazardous substances in electrical and electronic equipment" **2011/65/EU**.

The following standards have been applied:

**EN ISO 12100:2010, CISPR 12:2007, EN ISO 10517:2009/A1:2013, EN 50581:2012**

RISE SMP Svensk Maskinprovning AB, Box 7035, SE-750 07 Uppsala, Sweden has performed voluntary type examination on behalf of Husqvarna AB. The certificates are numbered: **SEC/10/2280-322HD60**

Huskvarna, 2019-05-01



Per Gustafsson, Development Manager (Authorized representative for Husqvarna AB and responsible for technical documentation)



[www.husqvarna.com](http://www.husqvarna.com)

Original instructions

1141925-38



2019-08-20