

Operator's Manual
P-ZT26 CE / 966791901

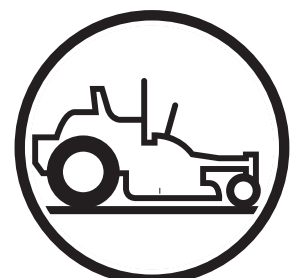

Please read these instructions carefully and make sure you understand the instructions before using the machine.

English

To implement improvements, specifications and designs can be altered without prior notification.

Note that no legal demands can be placed based on the information contained in these instructions.

Use only original parts for repairs. The use of other parts voids the warranty.

Do not modify or install non-standard equipment to the unit without consent from the manufacturer. Modifications to the unit may cause unsafe operations or damage the unit.

When this product is worn out and no longer used, it should be returned to the reseller or other party for recycling.

CONTENTS

INTRODUCTION	5	Running	31
Driving and Transport on Public Roads	5	Operating on Hills	32
Towing	5	Stopping the Engine	33
Operating	5	Mowing Tips	34
Good Service	6	Moving Machine By Hand	35
Manufacturing Number	6	MAINTENANCE	36
SYMBOLS AND DECALS	7	Maintenance Schedule	36
SAFETY	9	Battery	38
Safety Instructions	9	Safety System	39
Personal Safety Equipment	11	Tire Pressures	39
Slope Operation	11	Parking Brake	39
Safe Handling of Gasoline	13	Deck Belt	40
General Maintenance	14	Pump Belt	41
Transport	16	V-belts	41
Towing	16	Cutting Blades	42
Spark Arrestor	16	Adjusting the Mower Deck	43
Rollover Protection System (ROPS)	17	Leveling Deck	43
CONTROLS	18	Anti-scalp Rollers	44
Control Locations	18	Caster Wheels	44
Motion Control Levers	19	Hardware	45
Hour Meter	20	Cleaning	45
Tracking Knob	20	ZT-3400 Powertrain	45
Parking Brake	21	Lubrication Schedule	46
Blade Switch	21	LUBRICATION	46
Ignition Switch	21	Wheel and Deck Zerks	47
Fuses	23	Front Wheel Mount	47
Choke Control	23	Front Wheel Bearings	47
Cutting Height Controls	23	Deck Spindle	47
Seat Adjustment Lever	24	Transaxle Fluid Change	48
Fuel Shut Off Valve	24	TROUBLESHOOTING GUIDE	49
Hydro Release Levers	24	STORAGE	51
Refueling	25	Winter Storage	51
OPERATION	26	Service	51
Training	26	WIRING DIAGRAM	52
Steering	26	Torque Specifications	53
Roll Bar and Safety Belt	27	TECHNICAL DATA	53
Before Starting	27	CONFORMITY CERTIFICATES	56
Starting the Engine	28	SERVICE JOURNAL	57
Jumper Cables Use	30		



WARNING!

Failure to follow cautious operating practices can result in serious injury to the operator or other persons. The owner must understand these instructions, and must allow only trained persons who understand these instructions to operate the mower.

Each person operating the mower must be of sound mind and body and must not be under the influence of any mind altering substance.



WARNING!

Engine exhaust, some of its constituents, and certain vehicle components contain or emit chemicals known to the State of California to cause cancer and birth defects or other reproductive harm.



WARNING!

Battery posts, terminals and related accessories contain lead and lead compounds, chemicals known to the State of California to cause cancer and birth defects or other reproductive harm. Wash hands after handling.

INTRODUCTION

Congratulations

Thank you for purchasing a Husqvarna ride-on mower. This machine is built for superior efficiency to rapidly mow primarily large areas. A control panel easily accessible to the operator and a hydrostatic transmission regulated by steering controls both contribute to the machine's performance.

This manual is a valuable document. Read the contents carefully before using or servicing the machine. The following of instructions (use, service, maintenance) by all who operate this machine is important for the safety of the operator and others. It can also considerably increase the life span of the machine and increase its resale value.

If you sell your machine, be sure to give the operator's manual to the new owner.

The final chapter of this operator's manual provides a Service Journal. Ensure that service and repair work are documented. A well-kept service journal reduces service costs for the maintenance and affects the machine's resale value. Please contact your dealer for more information. Take the operator's manual along when the machine is taken to your dealer for service.

General

In this operator's manual, left and right, backward and forward are used in relation to the machine's normal driving direction.

Continuous dedication to improve our products require that specifications and design are subject to change without notice.

Driving and Transport on Public Roads

Check applicable road traffic regulations before transporting on public roads. If the machine is transported, you must always use approved fastening equipment and ensure that the machine is well anchored. DO NOT operate this machine on public roadways.

Towing

If machine is equipped with a tow hitch, use extreme caution when towing. Never allow children or others in or on the towed equipment. Make wide turns to avoid jack-knifing. Travel slowly and allow extra distance to stop.

Do not tow on sloped ground. The weight of the towed equipment may cause loss of traction and loss of control.

Follow the manufacturer's recommendation for weight limits for towed equipment. Do not tow near ditches, canals, and other hazards.

Operating

This machine is constructed only for mowing grass on lawns and even ground without obstacles such as stones, tree stumps, etc. The machine can also be used for other tasks when equipped with special accessories provided by the manufacturer. Operating instructions for the accessories are provided with delivery. All other types of uses are incorrect. The manufacturer's directions concerning operation, maintenance, and repairs must be carefully followed.

Lawn mowers and all power equipment can be potentially dangerous if used improperly. Safety requires good judgment, careful use in accordance with these instructions and common sense.

The machine must only be operated, maintained, and repaired by persons familiar with the machine's special characteristics and who are also knowledgeable about the safety instructions. Use only approved repair parts to maintain this machine. Accident prevention regulations, other general safety regulations, occupational safety rules, and traffic regulations must be followed without fail.

Unauthorized modifications to the design of the machine may absolve the manufacturer from liability for any resulting personal injury or property damage.

INTRODUCTION

Good Service

Husqvarna's products are sold all over the world and only in specialized retail stores with complete service. This ensures that you as a customer receive only the best support and service. Before the product is delivered, the machine has, for example, been inspected and adjusted by your retailer. See the certificate in the Service Journal in this operator's manual.

When you need spare parts or support in service questions, warranty issues, etc., please consult the following professional:

This manual belongs to the machine with the manufacturing number:	Engine	Transmission

Manufacturing Number

The machine's manufacturing number can be found on the printed plate affixed to the right side in the engine compartment. Stated on the plate, from the top are:

The machine's type designation (I.D.).

The manufacturer's type number (Model).

The machine's serial number (Serial no.)

Please have the type designation and serial number available when ordering spare parts.

The engine's manufacturing number is stamped either on one of the valve covers or an affixed serial plate.

The plate states:

The engine's model.

The engine's type.

Code

Please have these available when ordering spare parts.

The wheel motors and hydrostatic pumps have a barcode decal affixed at the rear.

SYMBOLS AND DECALS

These symbols are found on the machine and in the operator's manual.

Study them carefully so that you know what they mean.

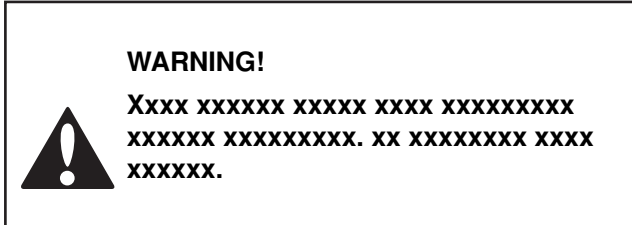

Used in this publication to notify the reader of a risk of personal injury or death, particularly if the reader should neglect to follow instructions given in the manual.

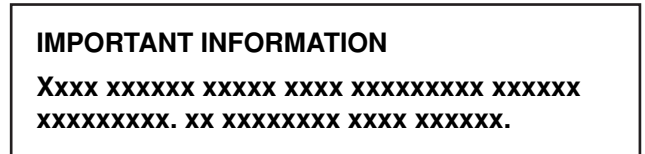

Used in this publication to notify the reader of a risk of material damage, particularly if the reader should neglect to follow instructions given in the manual. Used also when there is a potential for misuse or misassembly.



Reverse



Neutral



Fast



Slow



Choke



Fuel



Warning!



Parking Brake



CE conformity marking. Only for European market



Do not stand here,



Use protective glasses



Noise emissions to the surroundings in accordance with the European Union's directive. The machine's emission is stated in the chapter TECHNICAL DATA and on the decals.
 Only machines for European market



Electromagnetic Compatibility (EMC) Compliance
 New Zealand and Australia only



Use protective gloves

SYMBOLS AND DECALS

Read Operator's Manual	Shut off engine and remove key before performing any maintenance or repair work	Keep a safe distance from the machine	Use on slopes no greater than 10°	No passengers
Whole body exposure to thrown objects	Severing of fingers and toes	Do not open or remove safety shields while engine is running	Careful backing up, watch for other people	Careful going forward, watch for other people



Battery acid is corrosive, explosive and flammable

Moving sharp blades under cover

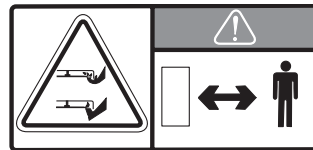

Warning! Rotating blades, keep away from the discharge deck

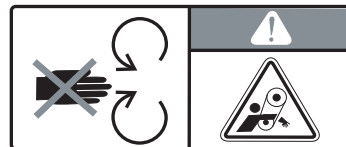

Do not touch parts

SAFETY

Safety Instructions

These instructions are for your safety. Read them carefully.



WARNING!

THIS CUTTING MACHINE IS CAPABLE OF AMPUTATING HANDS AND FEET AND THROWING OBJECTS. FAILURE TO OBSERVE THE FOLLOWING SAFETY INSTRUCTIONS COULD RESULT IN SERIOUS INJURY OR DEATH.



WARNING!

This symbol means that important safety instructions need to be emphasized. It concerns your safety.

General Operation

- Read, understand, and follow all instructions on the machine and in the manual before starting.
- It is recommended that someone be aware that you are mowing and can provide help in case of injury or accident.
- Do not put hands or feet near rotating parts or under the machine. Keep clear of the discharge opening at all times.
- Only allow responsible adults, who are familiar with the instructions, to operate the machine.
- Clear the area of objects such as rocks, toys, wire, etc., which could be picked up and thrown by the blades.
- Be sure the area is clear of bystanders before operating. Stop machine if anyone enters the area.
- Never carry passengers. The machine is only intended for use by one person.
- Do not mow in reverse unless absolutely necessary. Always look down and behind before and while backing.
- Never direct discharged material toward anyone. Avoid discharging material against a wall or obstruction. Material may ricochet back toward the operator. Stop the blades when crossing gravel surfaces.
- Do not operate machine without the entire grass catcher, discharge guard, or other safety devices in place and working
- Slow down before turning.
- Never leave a running machine unattended. Always turn off blades, set parking brake, stop engine, and remove keys before dismounting.

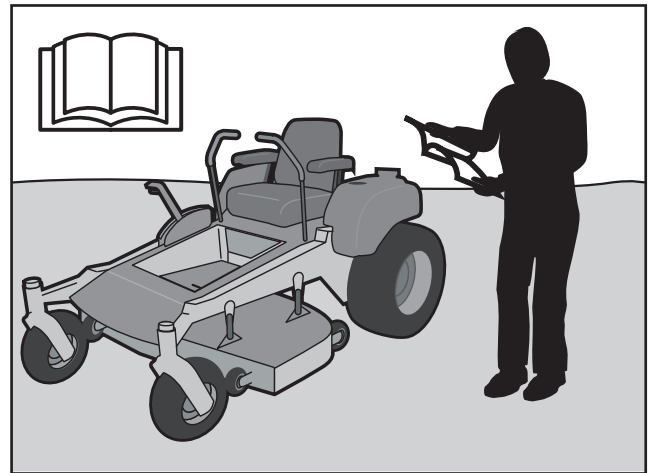

8011-512

Read the operator's manual before starting the machine

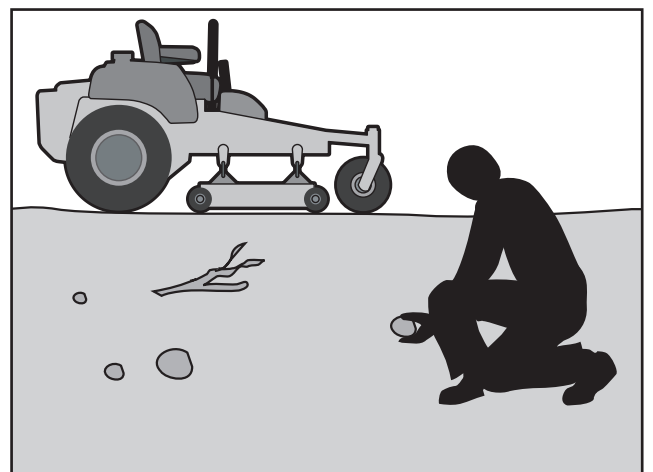

8011-513

Clear the area of objects before mowing

SAFETY

- Disengage blades when not mowing. Shut off engine and wait for all parts to come to a complete stop before cleaning the machine, removing the grass catcher, or unclogging the discharge guard.
- Operate machine only in daylight or good artificial light.
- Do not operate the machine while under the influence of alcohol or drugs.
- Watch for traffic when operating near or crossing roadways.
- Use extra care when loading or unloading the machine into a trailer or truck.
- Always wear eye protection when operating machine.
- Wear proper Personal Protective Equipment (PPE) while operating this machine, including (at a minimum) sturdy footwear, eye protection, and hearing protection. Do not mow in shorts and/or footwear with open toes.
- Data indicates that operators age 60 years and above are involved in a large percentage of riding mower-related injuries. These operators should evaluate their ability to operate the riding mower safely enough to protect themselves and others from serious injury.
- Follow the manufacturer's recommendation for wheel weights or counterweights.
- Anyone who operates this machine must first read and understand this Operation Manual. Local laws may regulate the age of the user.
- Keep machine free of grass, leaves or other debris buildup which can touch the hot exhaust or engine parts and burn. Do not allow the mower deck to plow leaves or other debris, causing buildup to occur.
- Clean any oil or fuel spillage before operating or storing the machine.
- Allow machine to cool before storage.



8011-520

Never take passengers



WARNING!

Engine exhaust and certain vehicle components contain or emit chemicals considered to cause cancer, birth defects, or other reproductive system damage. The engine exhaust contains carbon monoxide, which is an odorless, colorless, poisonous gas. Do not use the machine in enclosed spaces.

SAFETY

Personal Safety Equipment



WARNING!

When using the machine, approved personal protective equipment (shown in illustrations) shall be used. Personal protective equipment cannot eliminate the risk of injury but it will reduce the degree of injury if an accident does happen. Ask your retailer for help in choosing the right equipment.

- Make sure that you have first aid equipment close at hand when using the machine.
- Never use the machine when barefoot.
- Always wear protective shoes or boots, preferably with steel toe caps.
- Always wear approved protective glasses or a full visor when assembling or driving.
- Always wear gloves when handling the blades.
- Never wear loose clothing that can get caught in moving parts.
- Use ear protectors to avoid damage to hearing.

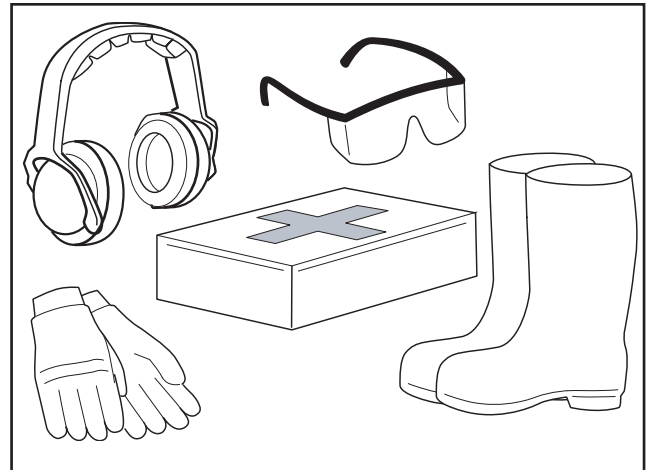

8011-670a

Personal protective equipment

Slope Operation

Slopes are a major factor related to loss of control and tip-over accidents, which can result in severe injury or death. Operation on all slopes requires extra caution. If you cannot back up the slope or if you feel uneasy on it, do not mow it.

- Mow up and down slopes (10 degrees maximum), not across.
- Watch for holes, ruts, bumps, rocks, or other hidden objects. Uneven terrain could overturn the machine. Tall grass can hide obstacles.
- Choose a low ground speed so that you will not have to stop while on the slope.
- Do not mow on wet grass. Tires may lose traction.
- Avoid starting, stopping, or turning on a slope. If the tires lose traction, disengage the blades and proceed slowly straight down the slope.
- Keep movement on the slopes slow and gradual. Do not make sudden changes in speed or direction, which could cause machine to roll over.
- Use extra care while operating machine with grass catchers or other attachments; they can affect the stability of the machine.

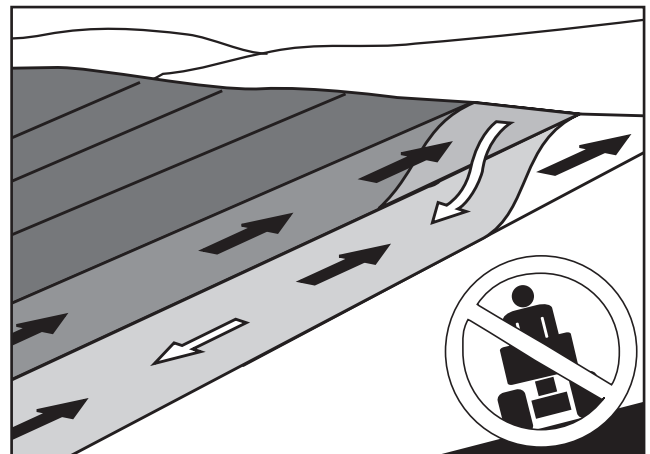

6003-004

Mow up and down, not side to side



WARNING!

Do not drive up or down hills with slopes greater than 10 degrees. Do not drive across any slopes.

SAFETY

- Do not use on steep slopes.
- Do not try to stabilize the machine by putting a foot on the ground.
- Do not mow near drop-offs, ditches, or embankments. The machine could suddenly roll over if a wheel is over the edge or if the edge caves in.



WARNING!

CHILDREN CAN BE INJURED BY THIS EQUIPMENT. The American Academy of Pediatrics recommends that children be a minimum of 16 years of age before operating a riding lawn mower. Keep children out of the mowing area and in the watchful care of a responsible adult other than the operator.

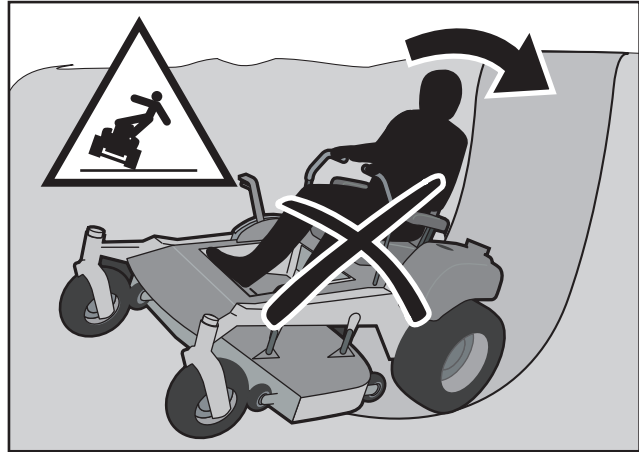

8011-519

Be extra cautious when driving on slopes

Children

Tragic accidents can occur if the operator is not alert to the presence of children. Children are often attracted to the machine and the mowing activity. **Never** assume that children will remain out of the path of danger.

- Keep children out of the mowing area and in the watchful care of a responsible adult other than the operator.
- Be alert and turn machine off if a child enters the area.
- Before and while backing, look behind and down for small children.
- Never carry children, even with the blades shut off. They may fall off and be seriously injured or interfere with safe machine operation. Children who have been given rides in the past may suddenly appear in the mowing area for another ride and be run over or backed over by the machine.
- Never allow children to operate the machine.
- Use extra care when approaching blind corners, shrubs, trees, or other objects that may block the view of a child.



8011-518

Keep children away from work area

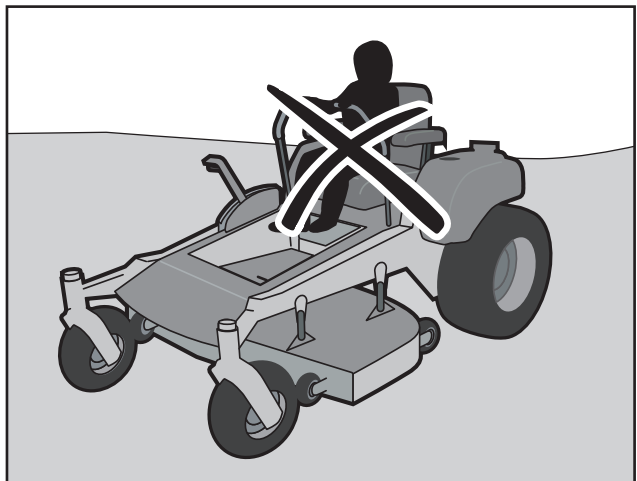

8011-517

Never allow children to operate the machine

SAFETY

Safe Handling of Gasoline



WARNING!

The engine and the exhaust system become very hot during operation.

There is risk for burns if touched.

Allow engine and exhaust system to cool before refueling.

To avoid personal injury or property damage, use extreme care in handling gasoline. Gasoline is extremely flammable and the vapors are explosive.

- Extinguish all cigarettes, cigars, pipes, and other sources of ignition.
- Use only approved gasoline container.
- Never remove gas cap or add fuel with the engine running. Allow engine to cool before refueling.
- Never fuel the machine indoors.
- Never store the machine or fuel container where there is an open flame, spark, or pilot light such as on a water heater or other appliance.
- Before beginning to refuel, minimize the risk of static electricity by touching a metal surface.
- Never fill containers inside a vehicle or on a truck or trailer bed with plastic liner. Always place containers on the ground away from the vehicle when filling.
- Remove gas-powered equipment from the truck or trailer and refuel it on the ground. If this is not possible, refuel such equipment with a portable container, rather than from a gasoline dispenser nozzle.
- Keep the nozzle in contact with the rim of the fuel tank or container opening at all times until fueling is complete. Do not use a nozzle lock-open device.
- If fuel is spilled on clothing, change clothing immediately.
- Never overfill fuel tank. Replace gas cap and tighten securely.
- Do not start the engine near spilled fuel.
- Never use gasoline as a cleaning agent.
- If leaks arise in fuel system, engine must not be started until problem has been resolved.
- Check the fuel level before each use and leave space for the fuel to expand, as the heat from the engine and the sun may otherwise cause the fuel to expand and overflow.



Never fill the fuel tank indoors

8011-516



WARNING!

The engine must not be started when the driver's floor plate or any protective plate for the mower deck's drive belt is removed.

SAFETY

General Maintenance

- Never operate machine in a closed area.
- Keep all nuts and bolts tight to be sure the equipment is in safe working condition.
- Never tamper with safety devices. Check their proper operation regularly.
- Keep machine free of grass, leaves, or other debris buildup. Clean oil or fuel spillage and remove any fuel-soaked debris. Allow machine to cool before storing.
- If the machine strikes a foreign object, stop and inspect the machine. Repair, if necessary, before restarting.
- Never make any adjustments or repairs with the engine running.
- Check grass catcher components and the discharge guard frequently and replace with manufacturer's recommended parts, when necessary.
- Mower blades are sharp. Wrap the blade or wear gloves, and use extra caution when servicing them.
- Check brake operation frequently. Adjust and service as required.
- Maintain or replace safety and instruction labels, as necessary.
- Do not modify safety equipment. Check regularly to be sure it works properly. The machine must not be driven with defective or unmounted protective plates, protective cowlings, safety switches, or other protective devices.
- Do not change the settings of governors and avoid running the engine with overly high engine speeds. If the engine runs too fast, there is risk for damaging the machine components.
- Be very careful when handling battery acid. Acid on skin can cause serious corrosive burns. If battery acid is spilled on skin, rinse immediately with water.
- Acid in the eyes can cause blindness, contact a doctor immediately.
- Be careful when servicing the battery. Explosive gases form in the battery. Never perform maintenance on the battery when smoking or near open flames or sparks.
- The battery can explode and cause serious injury or damage.
- Ensure that the equipment is in good condition and that all nuts and bolts, especially those fastening the blade attachments, are properly tightened and torqued.



8011-515

Never drive the machine in an enclosed space



CAUTION!

Use protective glasses for maintenance work.



WARNING!

The battery contains lead and lead compounds, chemicals that are considered to cause cancer, birth defects, and other reproductive system damage. Wash your hands after handling the battery.

SAFETY

Sparking can occur when working with the battery and the heavy cables of the starter circuit. This can cause battery explosion, fire or eye injury. Sparking in this circuit can not occur after the chassis cable (normally negative, black) is removed from the battery.



WARNING!

Avoid electrical sparking and its consequences by the following routines:

- Use protective goggles.
- Ensure that the fuel filler cap is mounted tightly and no flammable substances are stored in an open vessel.
- Never work with the starter circuit if there is spilled fuel.
- Disconnect the negative cable from the battery first and reconnect it last.
- Do not make a bridge short circuit across the starter relay to run the starter.
- Never use the machine indoors or in spaces lacking proper ventilation. The exhaust fumes contain carbon monoxide, an odorless, poisonous, and lethal gas.
- Stop to inspect the equipment if the machine runs over or into anything. If necessary, make repairs before starting.
- Never make adjustments with the engine running.
- The machine is tested and approved only with the equipment originally provided or recommended by the manufacturer. Only use approved repair parts for the machine.
- The blades are sharp and can cause cuts and gashes. Wrap the blades or use protective gloves when handling them.
- Check the parking brake's functionality regularly. Adjust and service as necessary.
- The mulch blades should only be used in familiar areas when higher quality mowing is desired.
- Reduce the risk of fire by removing grass, leaves, and other debris that may have accumulated on the machine.
- Allow the machine to cool before putting it in storage.
- Regularly clean deck and underside of deck, avoid spraying engine and electrical components with water.

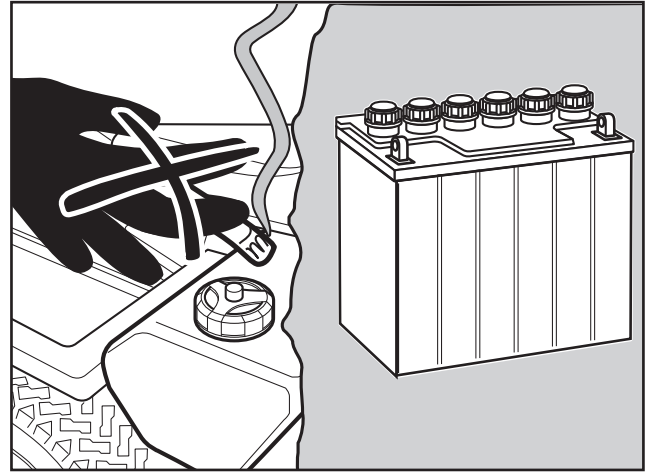

6003-009

Do not smoke when performing maintenance on the battery. The battery can explode and cause serious injury/damage.

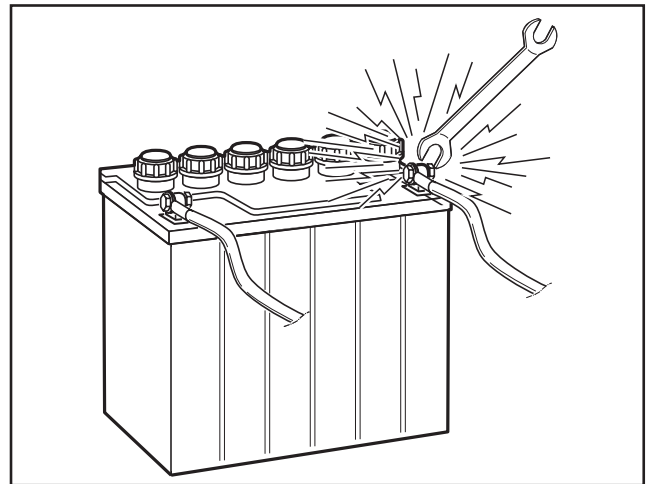

8009-728

Risk of sparking

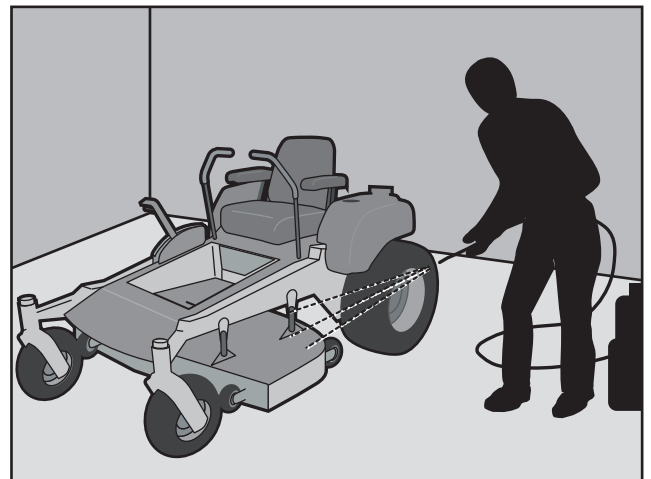

8011-514

Regularly clean deck

SAFETY

Transport

- The machine is heavy and can cause serious crushing injuries. Be extra cautious when it is loaded on or unloaded from a vehicle or trailer.
- Use an approved trailer to transport the machine. Activate the parking brake, turn off the fuel supply, and fasten the machine with approved fastening devices, such as bands, chains, or straps, when transporting.
- Do not operate this machine on public roadways.
- Check and abide by local traffic regulations before transporting the machine on any road.
- Do not tow this machine: it may cause damage to the drive system.
- Load the unit onto truck or trailer by driving up ramps of suitable strength using a slow speed. Do not lift! The machine is not intended to be lifted by hand.
- When loading or unloading this machine, do not exceed the maximum recommended operation angle of 10°.



WARNING!

Use extreme caution when loading the machine into a truck or trailer using ramps. There is the possibility of serious injury or death if the machine falls off the ramps.

IMPORTANT INFORMATION

The parking brake is not sufficient to lock the machine in place during transport. Ensure that the machine is well fastened to the transport vehicle. Always reverse the machine onto the transport vehicle to avoid tipping it over.

Towing

If machine is equipped with a tow hitch, use extreme caution when towing. Never allow children or others in or on towed equipment.

Make wide turns to avoid jack-knifing. Travel slowly and allow extra distance to stop. Do not tow on sloped ground. The weight of the towed equipment may cause loss of traction and loss of control.

Follow the manufacturer's recommendation for weight limits for towed equipment. Do not tow near ditches, canals, and other hazards.



WARNING!

Escaping hydraulic oil under pressure can have sufficient force to penetrate the skin, causing serious injury. If injured by escaping fluid, see a doctor at once. Serious infection or reaction can develop if proper medical treatment is not administered immediately.

Spark Arrestor

A spark arrestor for the muffler is available through any authorized Husqvarna dealer.



WARNING!

This mower is equipped with an internal combustion engine and should not be used on or near any unimproved forested, bush covered or grassy lands unless the engine's system is equipped with a spark arrestor meeting applicable local or state laws (if any). If a spark arrestor is used, it should be maintained in effective working order by the operator.

SAFETY

Rollover Protection System (ROPS)

The ROPS increases the basic weight of the unit by 73 lbs / 33 kg.

- Do not use ROPS as a lifting, attaching or anchoring point.
- Do not use ROPS for wrecking or towing.
- Do not exceed Max GVW: 2822 lbs/1283 kg.
- Read machine's operator manual before each use.
- Securely fasten the seat belt if the unit has a ROPS.
- Where possible, avoid operating the unit near ditches, embankments and holes.
- Reduce speed when turning, crossing slopes and on rough, slick or muddy surfaces.
- Stay off slopes too steep for safe operation.
- Watch where you are going, especially at row ends, on roads and around trees.
- Do not permit others to ride.
- Operate the mower smoothly - no jerky turns, starts or stops.
- When mower is stopped, set brakes securely and use park brake.
- If any part of ROPS is damaged, the entire ROPS must be replaced.
- Check all bolts including seat belt for correct torque before each use.
- Check ROPS structure for damage before each use.
- ROPS bar is NOT intended for use in sub zero temperatures.



WARNING!

The rollover protection system's capabilities may be impaired by damage if the mower is overturned or if alteration to the ROPS occurs. If these conditions take place, the total structure **MUST be replaced.**

CONTROLS

This operator's manual describes the Husqvarna Zero Turn Rider. The rider is fitted with a Kawasaki four-stroke overhead valve engine.

Transmission from the engine is made via belt-driven

hydraulic pumps. Using the left and right steering controls, the flow is regulated and thereby the direction and speed.

Control Locations

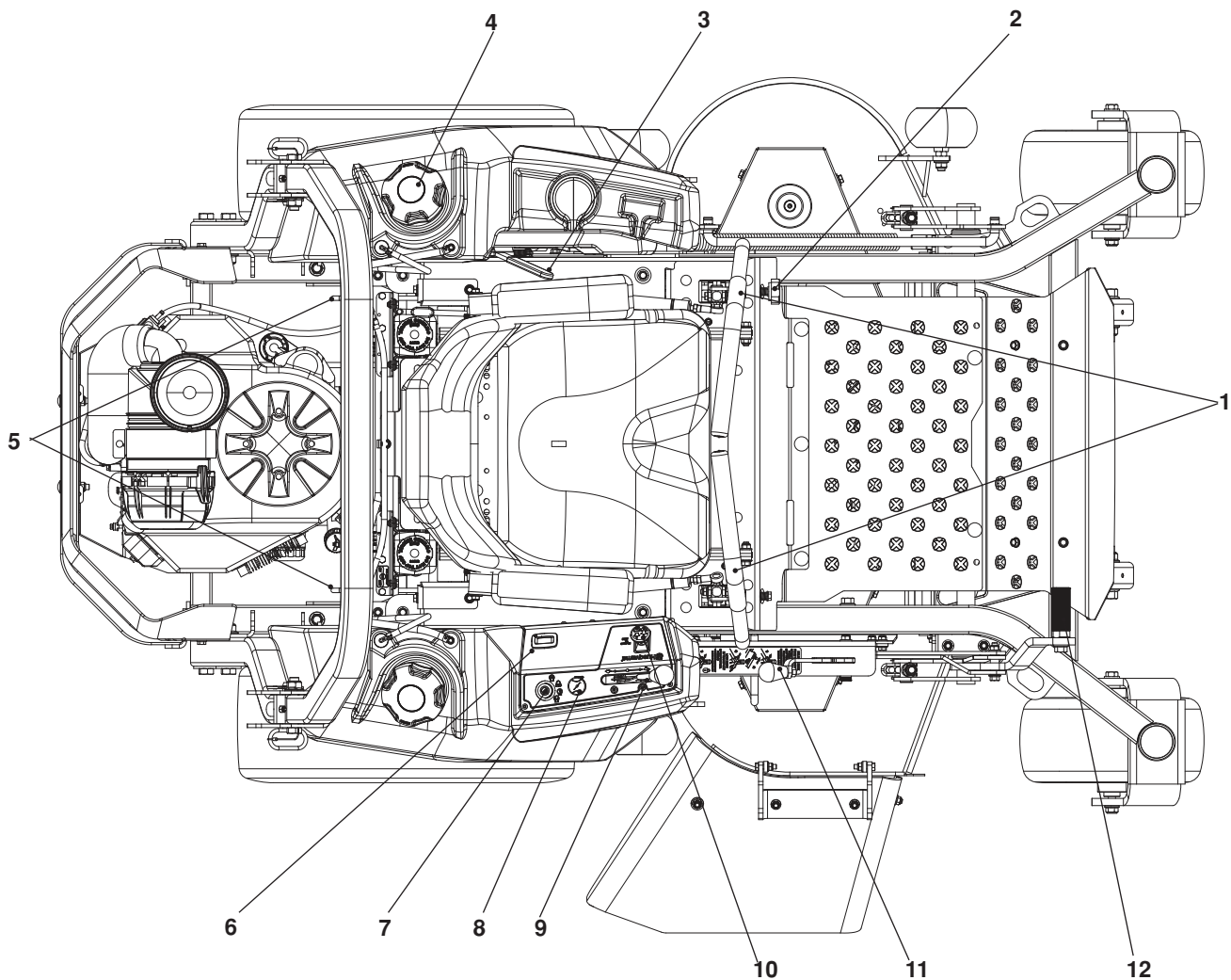

- | | |
|--------------------------|---------------------|
| 1. Motion control levers | 7. Ignition switch |
| 2. Tracking knob | 8. Choke control |
| 3. Parking brake | 9. Throttle control |
| 4. Fuel tank - left | 10. Blade switch |
| 5. Hydro releases levers | 11. Deck release |
| 6. Hour meter | 12. Deck lift |

CONTROLS

Motion Control Levers

The machine's speed and direction are continuously variable using the two steering controls. The steering controls can be moved forward or backward about a neutral position. Furthermore, there is a neutral position, which is locked if the steering controls are moved outward.

When both controls are in the neutral position (N), the machine stands still.

By moving both controls an equal amount forward or backward, the machine moves in a straight line forward or backward respectively.

For example, to turn right while moving forward, move the right control towards the neutral position. The rotation of the right wheel is reduced and the machine turns to the right.

Zero turn can be achieved by moving one control backward (behind the neutral position) and carefully moving the other steering control forward from its neutral position. The rotation direction when zero turning is determined by which steering control is moved backward behind the neutral position. If the left steering control is pulled backward, the machine turns to the left. Use extra care when using this maneuver.

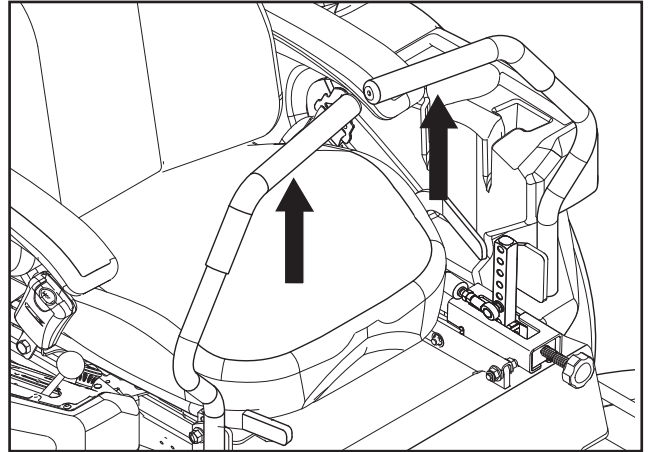

8065-105

Steering controls



WARNING!

The machine can turn very rapidly if one steering control is moved much further forward than the other.

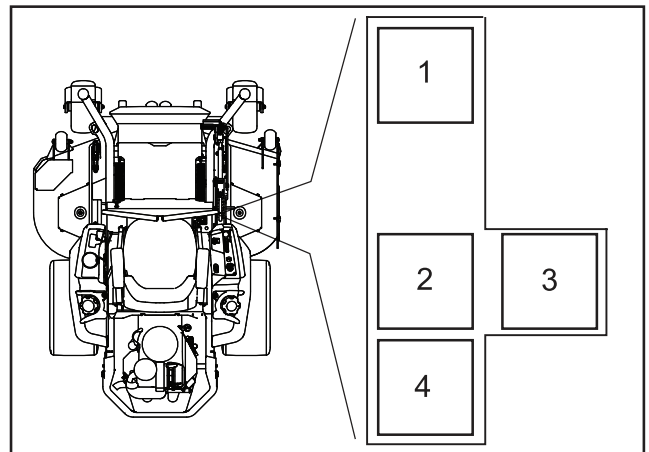

8065-053

1. Forward
2. Neutral
3. Neutral slot, Neutral lock
4. Reverse

Motion control lever pattern (right side)

CONTROLS

Hour Meter

The hour meter displays the total operating time. It will flash CHG OIL (Change Oil) at 50 hour intervals. The flash duration is one hour before and one hour after the interval. The CHG OIL icon will come on and shut off automatically. The hour meter cannot be manually reset.

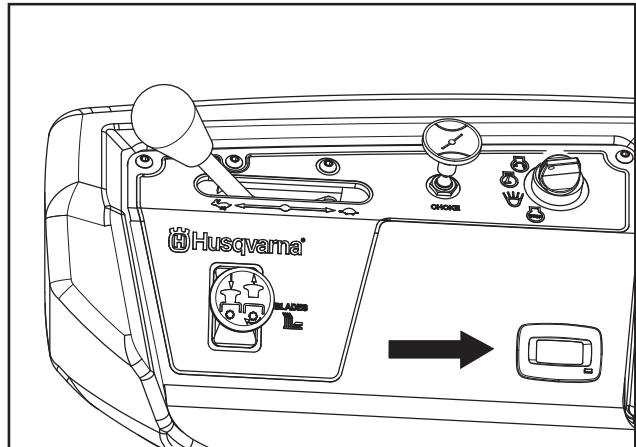

8065-084

Hour meter

Tracking Knob

If the mower is not tracking straight, check the air pressure in both rear tires. Recommended air pressure for the rear tires is 15 psi (1 bar).

1. Tracking adjustments are made using the tracking bolt and tracking knob. The tracking bolt and tracking knob act as limiting devices for the motion control levers when in the full-forward position.
2. For preliminary tracking adjustment, move unit to an open, unobstructed area such as an empty parking lot or open field.
3. Back the tracking bolt out until flush with nut.
4. Loosen tracking knob out until flush with nut.
5. Test operate unit by driving it at full throttle and the full forward position on both motion control levers. Gradually turn in the tracking bolt on the right hand side until the unit noticeably starts drifting right.
6. Drive forward at full throttle with both motion control levers in the full forward position. Gradually turn in the tracking knob (left side) until unit tracks straight.

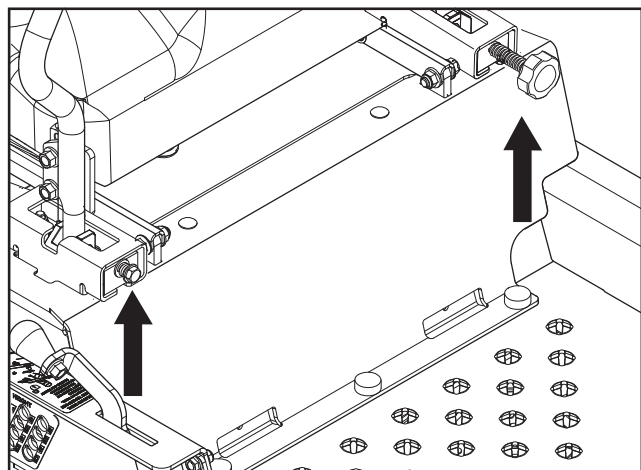

8065-106

Tracking adjustment

CONTROLS

Parking Brake

The parking brake is found on the left of the machine. Pull the lever backward to activate the brake and forward to release it.

IMPORTANT INFORMATION

The machine must stand absolutely still when applying the parking brake. Always set the parking brake before dismounting. Release the parking brake before moving the mower.

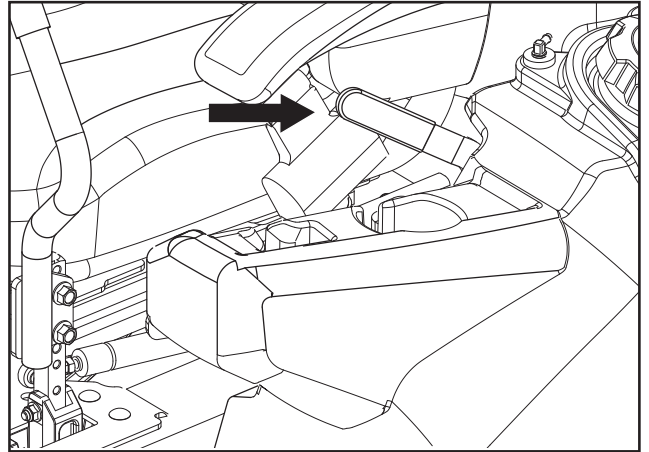

Parking brake

8065-006

Blade Switch

To engage the mower deck, pull the blade switch knob out. The mower blades are disengaged when the knob is pressed down fully.

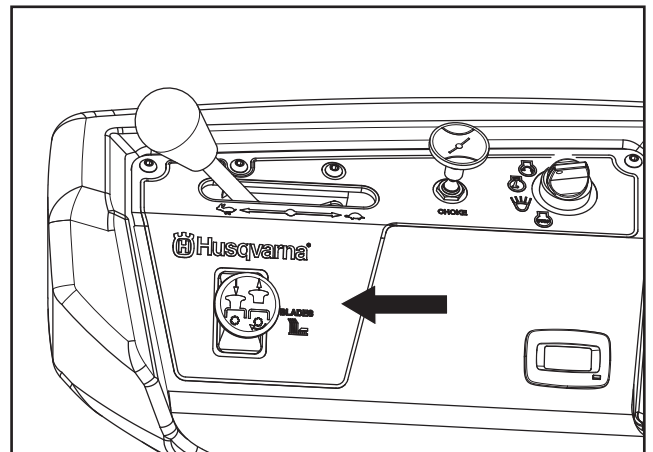

Blade switch

8065-084

Ignition Switch

The ignition switch is placed on the control panel and is used to start and stop the engine.

Push in and turn the key clockwise to start the engine.

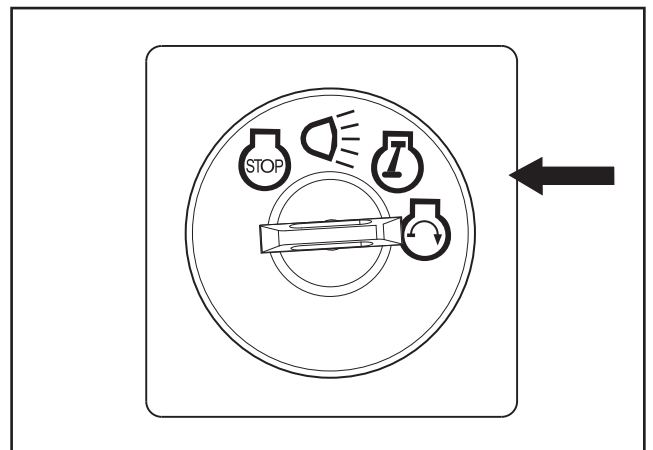

Ignition switch

8050-780

CONTROLS

Release the key to the RUN position when the engine has started.

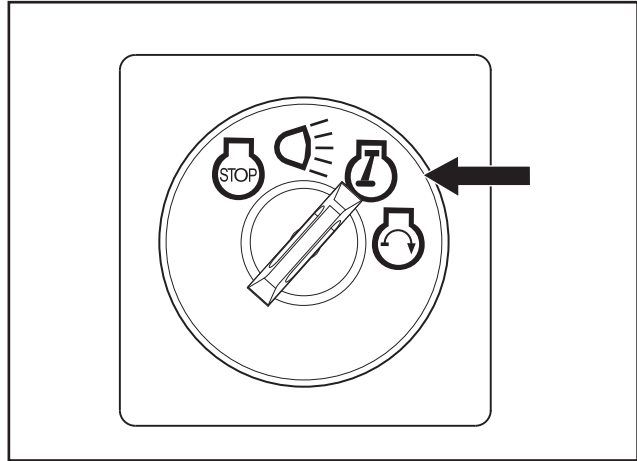

Ignition switch - RUN position

8050-781

On models equipped with headlights, turn the key clockwise to ACCESSORY for headlight use.

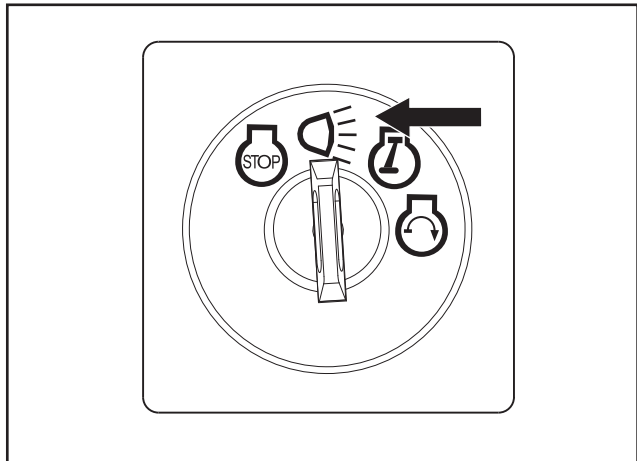

Ignition switch - accessory

8050-848

CONTROLS

Fuses

Fuses are located on the right hand side of the machine. They are accessed by tilting the seat forward. Fuses are flat pin fuses type as used in automobiles.

There are three fuses with ratings and functions:

1. 20 A, Primary fuse.
2. 7.5 A, Mower deck coupling.
3. 10 A, Accessories

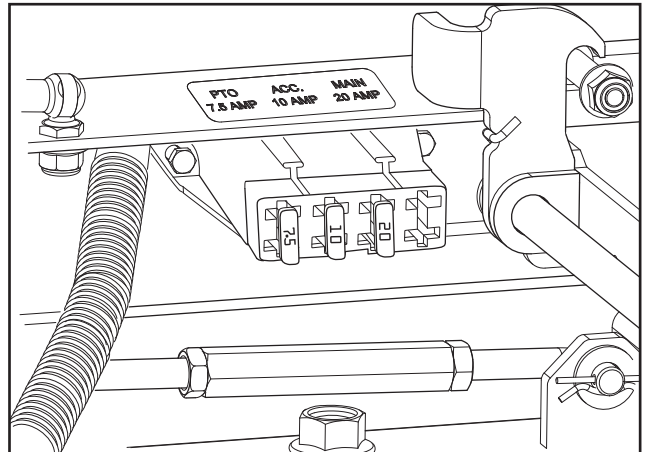

8065-043

Fuses

Choke Control

The choke control is used for cold starts to provide the engine with a richer fuel mixture.

For cold starts the control should be pulled out to its extent.

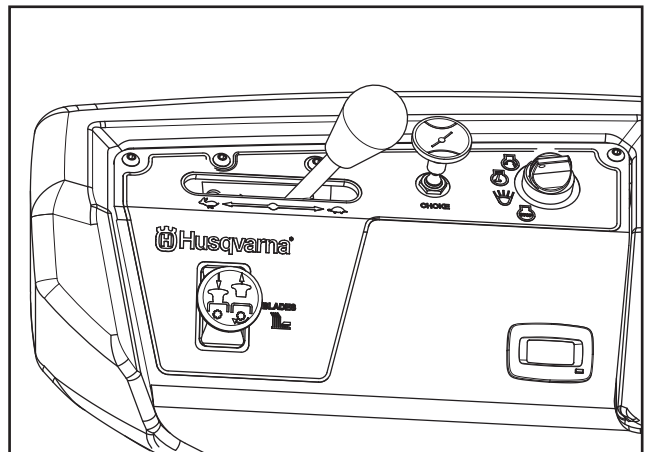

8065-085

Choke control

Cutting Height Controls

The cutting height pedal lifts the deck to allow setting the desired deck height. For transport, push the lift pedal fully forward until the deck lift latches in the transport (highest) position.

To set the deck cutting height, release deck height control by pushing forward on the pedal. Rotate the cutting height pin 180° to remove it and slip the pin into the hole for the desired cutting height. The cutting height can be set from 1"- 5½" (2.5 cm-14 cm).

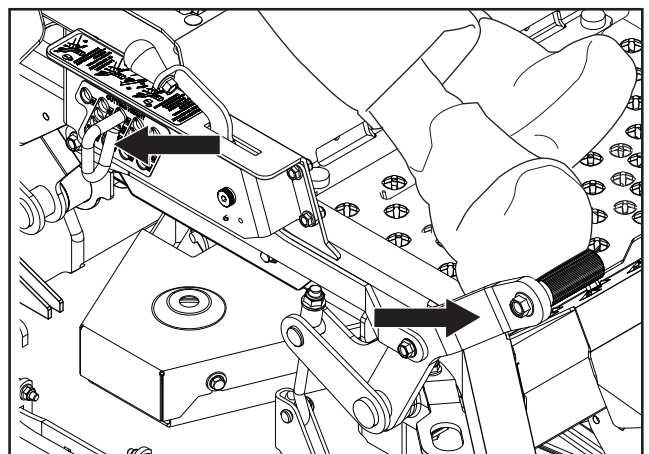

8065-087

Cut height lift pedal

CONTROLS

Seat Adjustment Lever

The seat can be adjusted lengthways. The lever is located under the right side of the seat (as seen by the driver in the seat). When making adjustments the lever is moved to the left.

IMPORTANT INFORMATION

Seat should not be adjusted while unit is in motion.

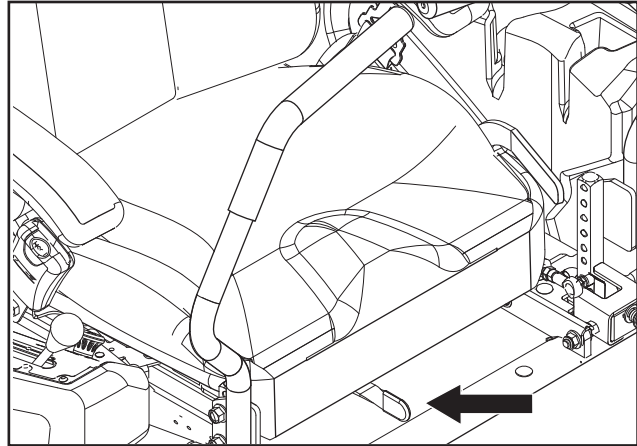

8065-088

Seat adjustment

Fuel Shut Off Valve

The fuel shut off valve is located at the right rear of the seat. The valve has three positions: right tank, left tank and OFF.

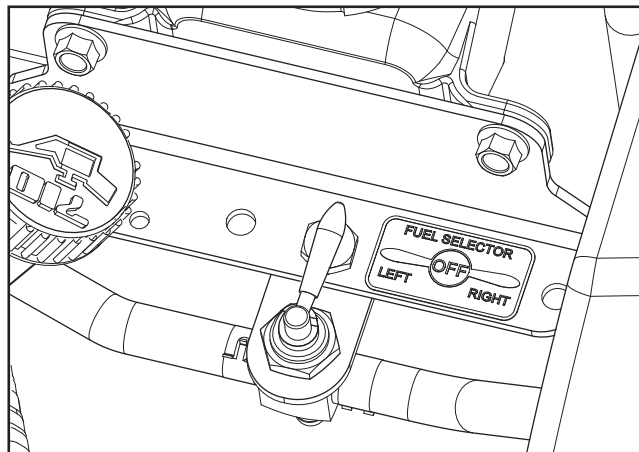

8065-010

Gas model fuel shut off valve in the CLOSED position.

Hydro Release Levers

The levers are located on each side of the rear of the unit below the rear engine plate. The bypass linkage is used when manual pushing or pulling the unit.

See **Moving Machine By Hand** in the **Operation** section.



WARNING!

Bypass linkages are located close to the muffler. To prevent burns, the engine should be shut off and allowed to cool before the bypass linkage levels are handled.

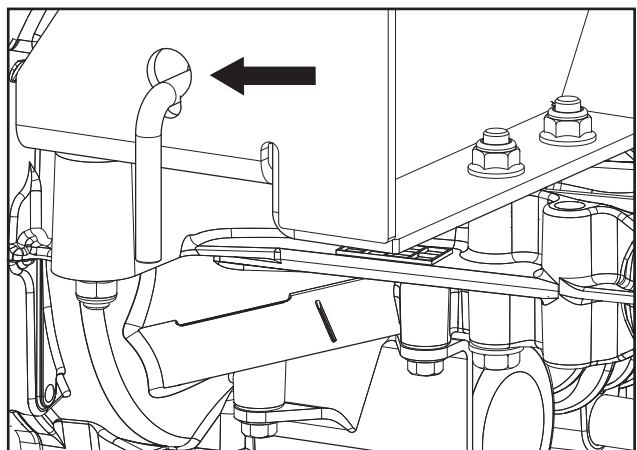

8065-097

Right side, ZT linkage

CONTROLS

Refueling

IMPORTANT INFORMATION

It is recommended that fuel be added to both tanks on initial start up.

Read the safety instructions before refueling. The machine has two fuel tanks, one on each side just behind the seat. The capacity for each tank is 5½ gallons (20.8 liters).

Regularly check the gas cap gasket for damage and keep the cap properly tightened.

The engine will run on a minimum of 87-octane unleaded gasoline (no oil mix). Environmentally adapted alkylate gasoline can be used. See Technical Data concerning ethanol fuel. Methanol fuel is not allowed. Do not use E85 alcohol based fuel. Damage to the engine and components may occur.

When operating in temperatures below 32° F. (0° C.), use fresh, clean winter grade gasoline to help insure good cold weather starting.

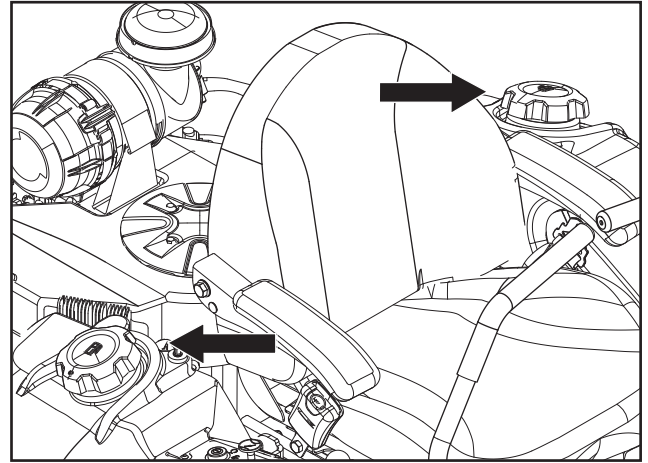

Gasoline fuel tanks

8065-007



WARNING!

Gasoline is highly flammable. Observe caution and fill the tank outdoors (see the safety instruction).



WARNING!

The engine and the exhaust system become very hot during operation. Risk for burns if touched. Allow engine and exhaust system to cool before refueling



WARNING!

Fill to bottom of filler neck. Do not overfill. Wipe off any spilled oil or fuel. Do not store, spill or use gasoline near an open flame.

IMPORTANT INFORMATION

Experience indicates that alcohol blended fuels (called gasohol, ethanol or methanol) can attract moisture which leads to separation and formation of acids during storage. Acidic gas can damage the fuel system of an engine while in storage. To avoid engine problems, the fuel system should be emptied before storage of 30 days or longer. Drain the gas tank, start the engine and let it run until the fuel lines and carburetor are empty. Use fresh fuel the next season. See Storage Instructions for additional information. Never use engine or carburetor cleaners in the fuel tank or permanent damage may occur.

OPERATION

Read the **Safety** section and following pages, if you are unfamiliar with the machine.

Training

Due to unique steering capabilities, zero turn mowers are far more maneuverable than typical riding mowers.

This section should be reviewed in its entirety prior to attempting to move the mower under its own power.

When first operating the mower or until becoming comfortable with controls, use a reduced throttle speed and reduced ground speed. DO NOT move control levers to the furthest forward or reverse positions during initial operation.

First time users should become familiar with the mower's movement on a hard surface, such as concrete or blacktop PRIOR to attempting to operate on turf. Until the operator becomes comfortable with the mower controls and zero turning capability, overly aggressive maneuvers may damage turf.

Steering

To move forward and backward

The direction and speed of the mower's movements are effected by the movement of the control lever(s) on each side of mower. The left control lever controls the left wheel. The right control lever controls the right wheel.

First time users should push the mower (see *Moving Machine By Hand* in the **Operation** section) to an open, flat area without other people, vehicles or obstacles nearby. To move the unit under its own power, the operator must sit in the seat and start the engine (see *Before Starting* in the **Operation** section). Adjust the engine speed to idle, disengage the parking brake but do not engage the blades at this time. Rotate control levers inward. As long as the control levers have not been moved forward or backwards, the mower will not move.

Slowly move both control levers forward slightly. This will allow mower to start moving forward in a straight line. Pull the control levers back to the neutral position and the mower should stop moving.

Pull back slightly on control levers, allowing the mower to move backwards. Push the control levers forward to the neutral position and mower should stop moving.

To turn to the right

While moving in a forward direction, pull the right lever back towards the neutral position while maintaining the position of the left lever, this will slow the rotation of the right wheel and cause the machine to turn in that direction.

To turn to the left

While moving in a forward direction pull the left lever back towards the neutral position while maintaining the position of the right lever, this will slow the rotation of the left wheel and cause the machine to turn in that direction.

To zero turn

While moving in a forward direction, first pull both control levers back until the mower stops or slows dramatically.

Then by alternating one lever slightly to the forward position and the other in the reverse position, complete the turn.

IMPORTANT INFORMATION

When control levers are in the reverse position they return to neutral when released. This may cause the mower to suddenly stop.

OPERATION

Roll Bar and Safety Belt

Operate the unit with the roll bar in the raised and locked position and use the seat belt. There is no rollover protection when the roll bar is down. If it is necessary to lower roll bar, do not wear the seat belt. Raise the roll bar as soon as clearance permits.



WARNING!

The seat belt must be used when the roll bar is in upright position.

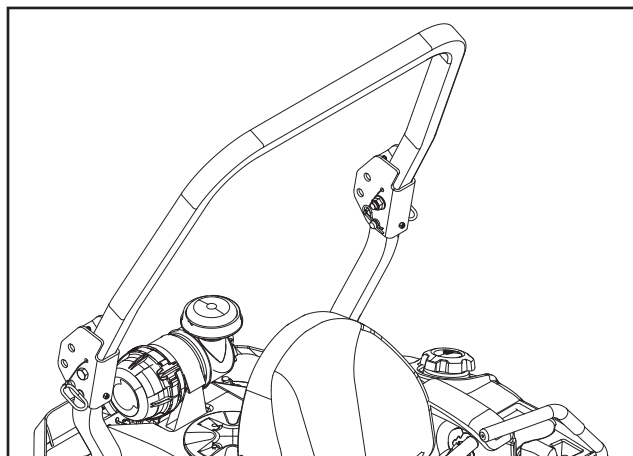

Roll bar in upright position

8065-011

Before Starting

1. Read the sections **Safety** and **Controls** before starting the machine.
2. Perform the daily maintenance before starting. See **Maintenance Schedule** in the **Maintenance** section.
3. Check that there is sufficient fuel in the fuel tank.
4. Adjust the seat to the desired position.

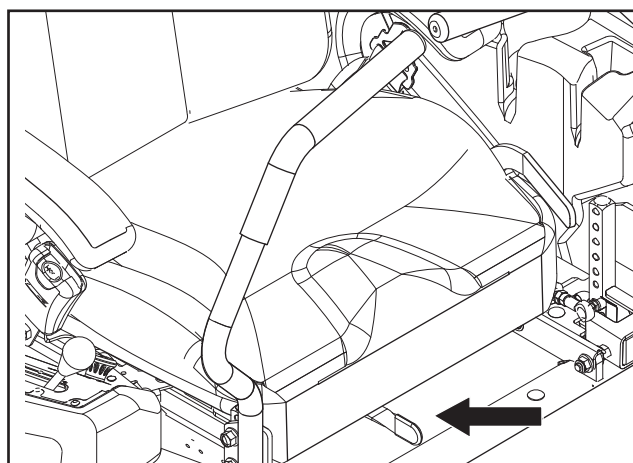

Seat adjustment

8065-088

5. Set the deck cutting height.

The following conditions must be fulfilled before the engine can be started:

- The blade switch for engaging the mower blades must be depressed.
- The parking brake must be on.
- Both steering controls must be in the locked (outer) neutral position.

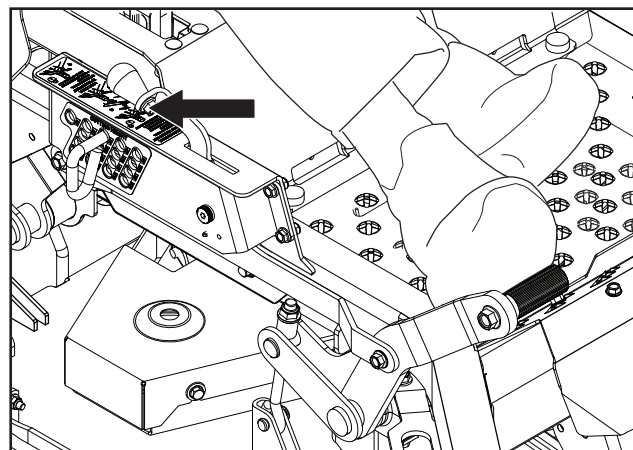

Set deck cutting height

8065-090

OPERATION

Starting the Engine

1. Sit on the seat.
2. Raise the mower deck to the transport position by setting the lift pedal fully forward.
3. Activate the parking brake.

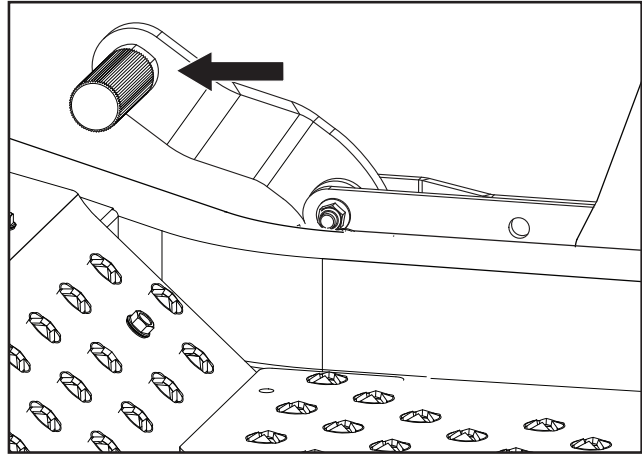

8065-087

Set mower deck to the transport position

4. Disengage the mower blades by pressing the blade switch down.

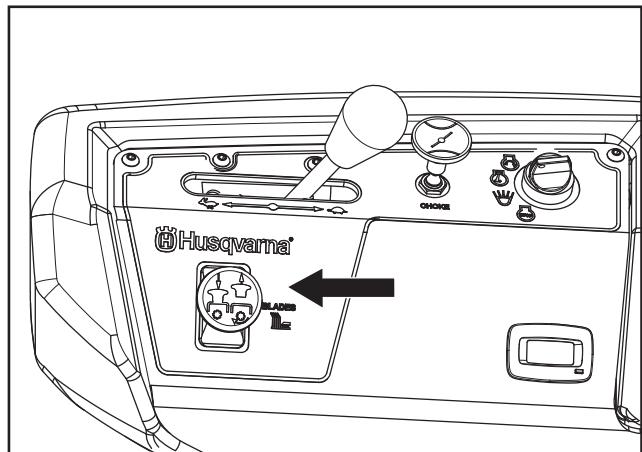

8065-085

Press the control for disengaging the mower deck

5. Move the steering controls outward to the locked (outer) neutral position.

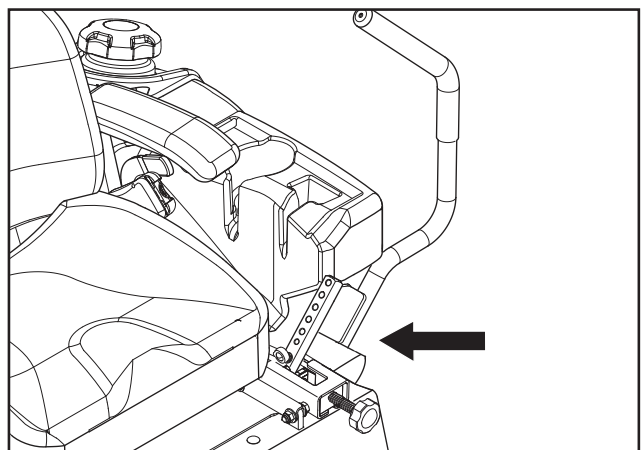

8065-194

Place controls in neutral position

OPERATION

6. Move the throttle to the middle position.
7. If the engine is cold, the choke control should be pulled fully up.



WARNING!

Engine exhaust and certain vehicle components contain or emit chemicals considered to cause cancer, birth defects or other reproductive system damage. The engine exhaust contains carbon monoxide, which is an odorless, colorless, poisonous gas. Do not use the machine in enclosed spaces.

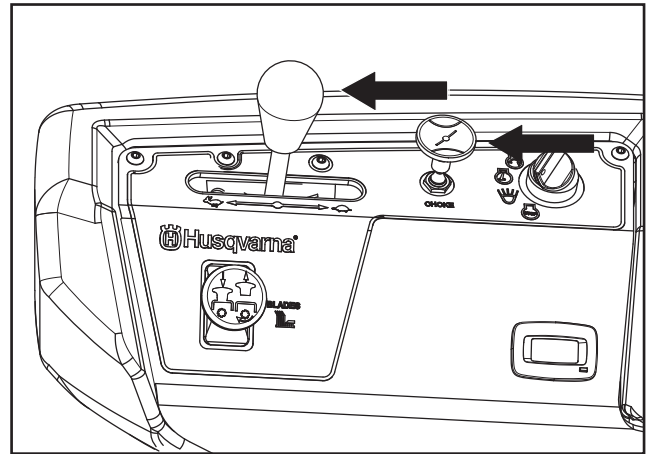

Set the throttle and choke

8065-089

8. Open the fuel tank valve for the selected tank.
9. Press in and turn the ignition key to the start position.

IMPORTANT INFORMATION

Do not run the starter for more than 5 seconds each time. If the engine does not start, wait about 10 seconds before retrying.

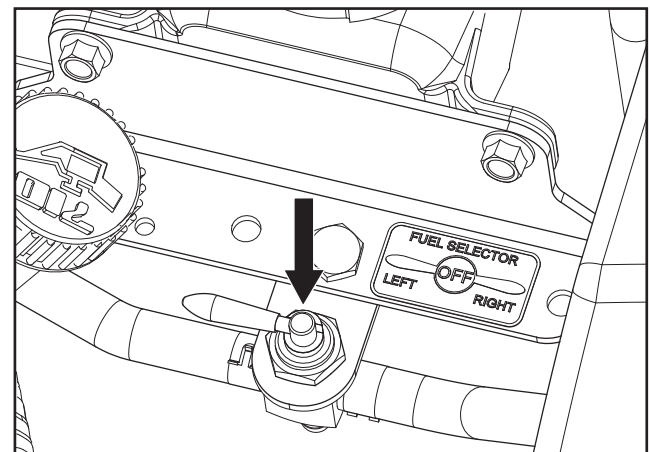

Fuel tank valve OPEN

8065-098

10. When the engine starts, immediately release the ignition key back to the run position.
11. Push the choke control in gradually when the engine has started.
12. Set the engine speed with the throttle. Allow the engine to run at a moderate speed, approximately mid throttle, for 3-5 minutes before loading it too heavily. **USE FULL THROTTLE WHEN MOWING** (no choke).

OPERATION

Weak Battery

If the battery is too weak to start the engine, it should be recharged. (See **Battery** in the *Maintenance* section.)



WARNING!

Lead-acid batteries generate explosive gases. Keep sparks, flame and smoking materials away from batteries. Always wear eye protection when around batteries.



IMPORTANT INFORMATION

The mower is equipped with a 12-volt negative grounded system. The other vehicle must also be a 12-volt negative grounded system. Do not use the mower to start other vehicles.

Jumper Cables Use

1. Connect each end of the RED cable to the POSITIVE (+) terminal on each battery, taking care not to short against chassis.
2. Connect one end of the BLACK cable to the NEGATIVE (-) terminal of the fully charged battery.
3. Connect the other end of the BLACK cable to a good CHASSIS GROUND on the mower with the discharged battery, away from the fuel tank and battery.

To remove cables, reverse order

4. Remove BLACK cable first from chassis and then from the fully charged battery.
5. Remove RED cable last from both batteries.

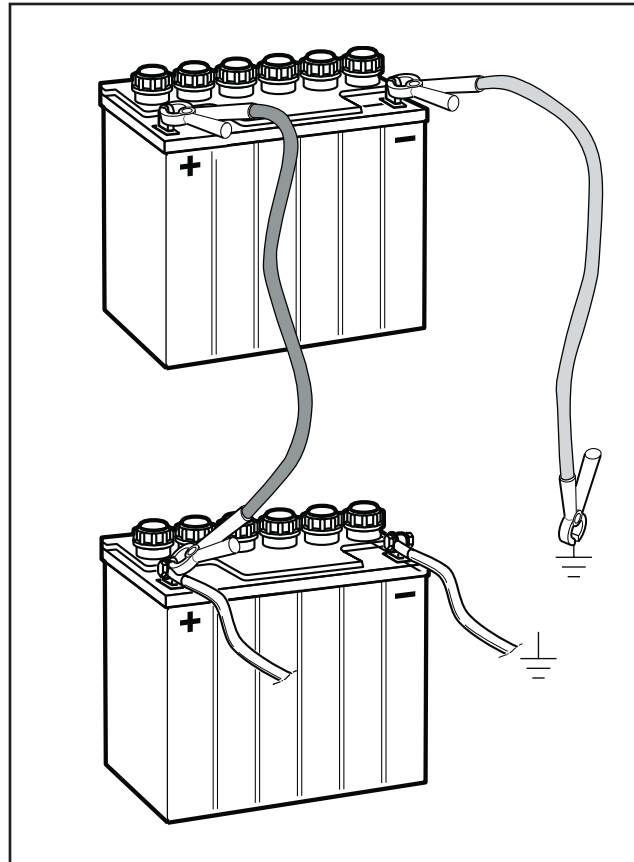

Jumper cable connection

8011-642

OPERATION

Running

1. Release the parking brake by moving the lever downward.
NOTE: The mower is equipped with an operator presence system. When the engine is running, any attempt by the operator to leave the seat without first setting the parking brake will shut off the engine.

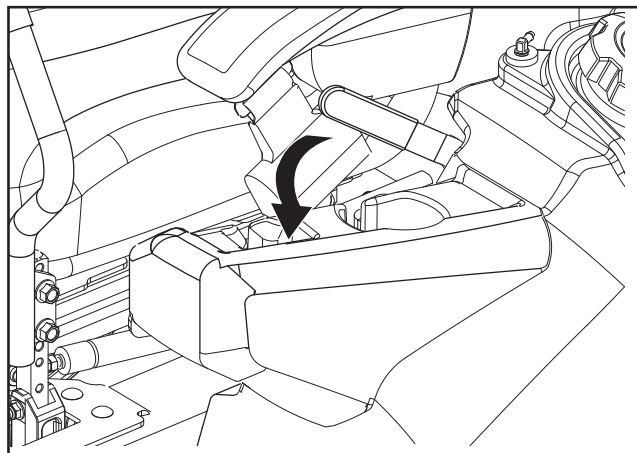

8065-006

Release the parking brake

2. Move the steering controls to the neutral position (N).



WARNING!

Make sure that no one is near mower when engaging blade switch.

Make sure the work area is free from objects that could be thrown by the rotating blades.

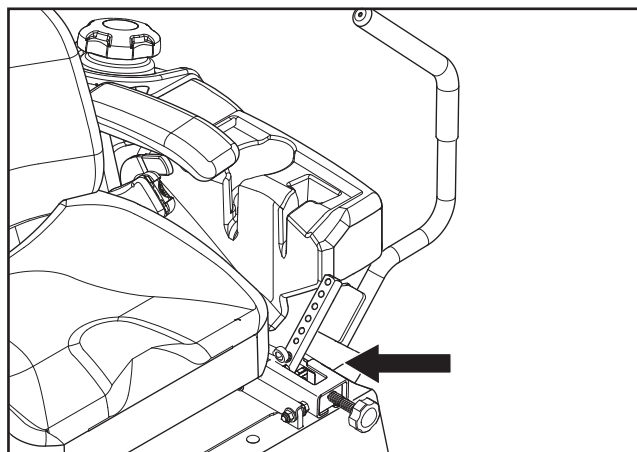

8065-194

Place controls in neutral position

3. Move throttle control to full throttle.
4. Engage the mower deck by pulling out the blade switch.

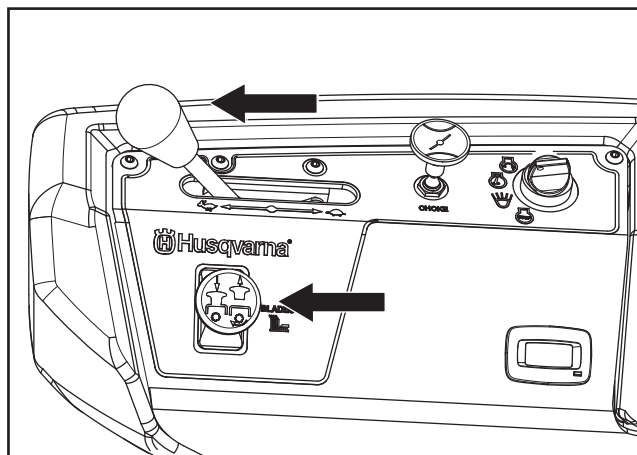

8065-084

Engage the mower deck and move throttle to full.

OPERATION

Operating on Hills

Read the Safety Instructions *Driving on Slopes* in the **Safety Instructions**.



WARNING!

Do not drive up or down hills with slopes greater than 10 degrees. Do not drive across slopes.

- The slowest speed possible should be used before starting up or down hills.
- Avoid stopping or changing speed on hills.
- If stopping is absolutely necessary, pull drive levers into the neutral position and push to the outside of the unit and engage the parking brake.
- To restart movement, release the parking brake.
- Pull the control levers back to the center of the mower and press forward to regain forward motion.
- Make all turns slowly.

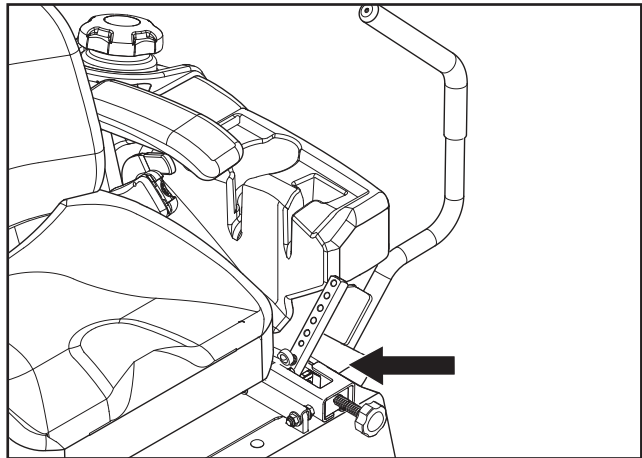

Place controls in neutral position

8065-194

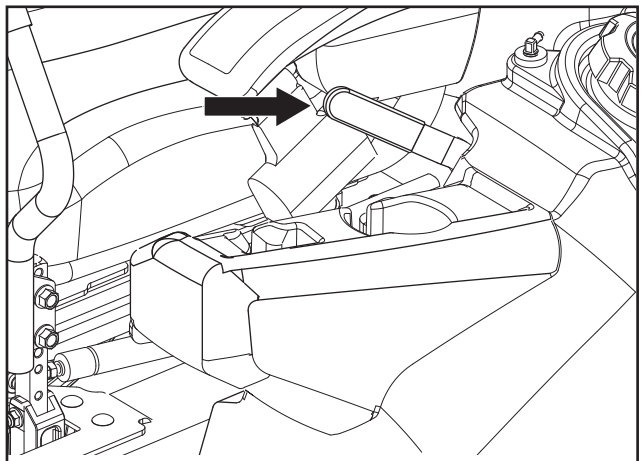

Release the parking brake

8065-006

OPERATION

Stopping the Engine

For all models, move the throttle to the minimum position (tortoise symbol). If the engine has been worked hard, allow it to idle a minute to attain a normal operating temperature before stopping. To prevent fouling the spark plugs, avoid idling the engine for longer periods.

1. Disengage the mower deck by depressing the blade switch.

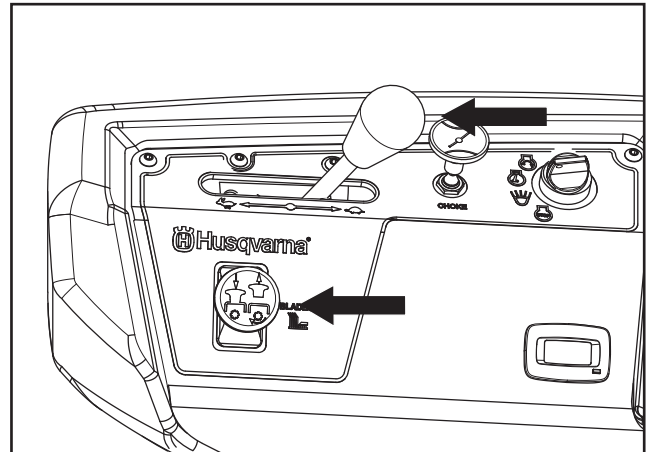

8065-085

Disengage the mower deck and move throttle to minimum

2. Raise the mower deck by pressing the foot pedal forward to the transport position.
3. When the machine is standing still, activate the parking brake by pulling the lever upward.
4. Turn the ignition key to the stop position.
5. Move the steering controls outward.

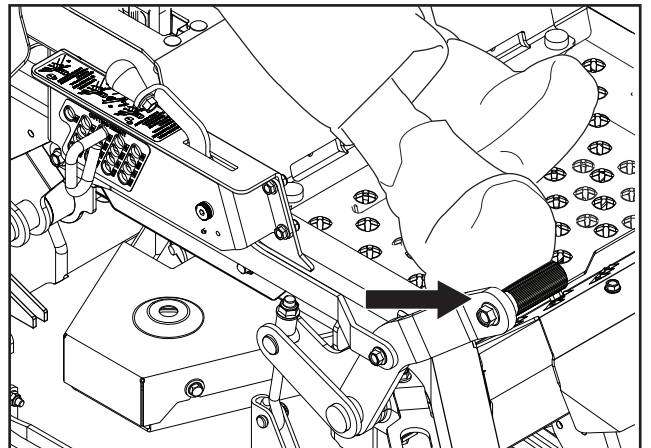

8065-090

Raise deck to transport position

6. Remove ignition key. To prevent unauthorized use, always remove the key when leaving the mower.

IMPORTANT INFORMATION

Leaving the ignition switch in any other position than OFF will cause the battery to be discharged.

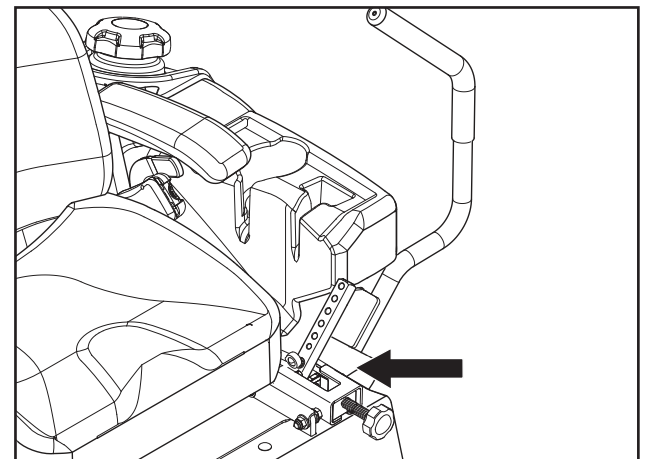

8065-194

Place controls in neutral position to stop

OPERATION

Mowing Tips

- Observe and flag rocks and other fixed objects to avoid collisions.
- Begin with a high cutting height and reduce it until the desired mowing result is attained. The average lawn should be cut to 64 mm (2½") during the cool season and over 76 mm (3") during the hot months. For healthier and better looking lawns, mow often after moderate growth.
- For best cutting performance, grass over 15 cm (6") in height should be mowed twice. Make the first cut relatively high; the second to the desired height.
- The mowing result will be best with a high engine speed (the blades rotate rapidly) and low speed (the rider moves slowly). If the grass is not too long and dense, the driving speed can be increased without negatively affecting the mowing result.
- The finest lawns are obtained by mowing often. The lawn becomes more even and the grass clippings more evenly distributed over the mown area. The total time taken is not increased as a higher operating speed can be used without poor mowing results.
- Avoid mowing wet lawns. The mowing result is poorer because the wheels sink into the soft lawn, clumps build, and the grass clippings fasten under the cowling.
- Hose the mower deck underside with water after each use. When cleaning, the mower deck shall be raised into the transport position. Make sure the mower is cooled and the engine is off.
- Use compressed air to clean top surface of the deck. Avoid flooding water on top surface, engine and electrical components.
- When the mulching kit is used, it is important that the mowing interval is frequent and that the deck is cleaned more often.



WARNING!

Clear the lawn of stones and other objects that can be thrown out by the blades.

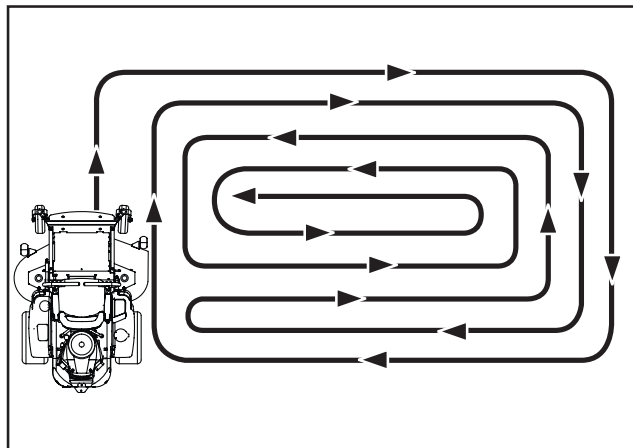

Mowing pattern

8011-603b



WARNING!

Never drive the rider on terrain that slopes more than 10 degrees. Mow slopes up and down, never side to side. Avoid sudden directional changes.

OPERATION

Moving Machine By Hand



WARNING!

No adjustments or maintenance should be carried out unless:

- the engine stopped
- the ignition key removed
- the parking brake activated

When pushing or pulling the mower, engage the bypass linkages with the hydro release levers. The levers are located on each side of the rear of the unit below the engine plate.

Raise the deck to the highest (transport) position.

Pull the bypass linkages up and out of the keyhole slots. Release the lever with the head outside the bracket and held into the bypass setting.

To reengage the hydro to drive, reverse the above procedure.

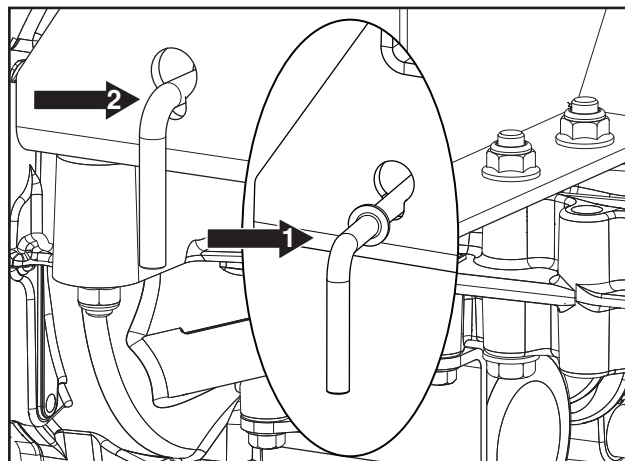

8058-091

1. Release lever locked into the bypass position

2. Release lever, engaged

Right side, ZT-3400 linkage



WARNING!

Bypass linkages are located close to the muffler. To prevent burns, the engine should be shut off and allowed to cool before the bypass linkage levels are handled.

MAINTENANCE

Maintenance Schedule

The following is a list of maintenance procedures that must be performed on the machine. For those points not described in this manual, visit an authorized service workshop. An annual service carried out by

an authorized service workshop is recommended to maintain your machine in the best possible condition and to ensure safe operation.

Read **Maintenance** in the **Safety** section.

MAINTENANCE	Daily		At least once each year	Maintenance interval in hours		
	Before	After		50	250	500
Check the parking brake	●					
Check the engine's oil level (every refueling)	■					
Check the safety system	●					
Check for fuel and oil leakages	◆					
Check/clean the engine's cooling air intake		■				
Check the mower deck		●				
Check for loose hardware (screws, nuts)		●				
Clean under the mower deck		●		●	●	●
Start the engine and blades, listen for unusual sounds		◆				
Check for damage		◆		◆	◆	◆
Thoroughly clean around the engine		◆		◆	◆	◆
Clean around belts, belt pulleys		◆		◆	◆	◆
Check the tire pressures		●		●	●	●
Check battery connections			●	●	●	●
Sharpen ³⁾ / Replace mower blades			●	●	●	●
Clean the engine's cooling air intake ²⁾			■	■	■	■
Clean the air cleaner foam pre-filter ²⁾			■		■	
Clean the air cleaner paper filter cartridge ²⁾			■		■	
Check/adjust the parking brake			●	●	●	●
Inspect muffler/spark arrester			◆	◆	◆	◆

¹⁾ First change after 8-10 hours. When operating with a heavy load or at high ambient temperatures, replace every 50 hours.

²⁾ In dusty conditions, cleaning and replacement are required more often.

³⁾ Performed by authorized service workshop.

● = Described in this manual

◆ = Not described in this manual

■ = Refer to the engine manufacturer's manual

MAINTENANCE

MAINTENANCE	Daily		At least once each year	Maintenance interval in hours		
	Before	After		50	250	500
Check/adjust throttle cable					■	
Check the condition of belts, belt pulleys			●		●	
Change the engine oil ¹⁾			■	■		
Replace the engine oil filter			■		■	
Clean/replace the spark plugs			■		■	
Replace the fuel filter			●		●	
Replace paper air filter ²⁾			■		■	
Check the caster wheels (every 200 hours)			●		●	
Replace the air cleaner foam pre-filter ²⁾			■			
Change the hydraulic oil (every 500 hours)			●			●
Replace the hydraulic oil filter (every 500 hours)			●			●
Dismantle and inspect starter ³⁾ (every 500 hours)						◆
Check/adjust the mower deck			●			●
Check the engine valve clearance ³⁾			◆			◆
Perform the 500-hour service ³⁾			◆			◆

¹⁾ First change after 5-8 hours. When operating with a heavy load or at high ambient temperatures, replace every 50 hours. ²⁾ In dusty conditions, cleaning and replacement are required more often. ³⁾ Performed by authorized service workshop.

● = Described in this manual

◆ = Not described in this manual

■ = Refer to the engine manufacturer's manual



WARNING!

Before performing any service or adjustment checklist:

- Engage the parking brake.
- Place the Blade-switch in the disengaged position.
- Turn the ignition switch to OFF position and remove the key.
- Make sure the blades and all moving parts have completely stopped.
- Disconnect the spark plug wire from all spark plugs and place the wire where it cannot come in contact with the plug.

MAINTENANCE

Battery

The mower is equipped with a maintenance free battery and does not need servicing. However, periodic charging of the battery with an automotive type battery charger will extend its life.

- Keep battery and terminals clean.
- Keep battery bolts tight.
- See chart for charging times.

STANDARD BATTERY	STATE OF CHARGE	APPROXIMATE BATTERY CHARGING TIME* TO FULL CHARGE AT 80°F / 27°C			
		Maximum Rate at:			
		50 Amps	30 Amps	20 Amps	10 Amps
12.6V	100%	- FULL CHARGE -			
12.4V	75%	20 min.	35 min.	48 min.	90 min.
12.2V	50%	45 min.	75 min.	95 min.	180 min.
12.0V	25%	65 min.	115 min.	145 min.	280 min.
11.8V	0%	85 min.	150 min.	195 min.	370 min.

*Charging time depends on battery capacity, condition, age, temperature and efficiency of charger



WARNING!

Always wear eye protection when around batteries.

Battery Removal

Corrosion and dirt on the battery and terminals can cause the battery to lose power.

1. Lift the seat and rotate fully forward until supported by the seat rod.
2. Loosen the two wingnuts attached to the side "J" bolts just enough that the battery mount bracket slides down off the battery.
3. Using two ½" wrenches disconnect BLACK battery cable then RED battery cable.
4. Carefully remove the battery from the mower.

Cleaning

5. Rinse the battery with plain water and dry.
6. Clean terminals and battery cable ends with a wire brush until shiny.

IMPORTANT INFORMATION

Do not attempt to open or remove caps or covers. Adding or checking level of electrolyte is not necessary.

Always use two wrenches for the terminal screws.



WARNING!

Do not short battery terminals by allowing a wrench or any other object to contact both terminals at the same time. Before connecting battery, remove metal bracelets, wristwatch bands, rings, etc.

Positive terminal must be connected first to prevent sparks from accidental grounding.

Replacing

7. Install the new battery with terminals in the same position as the old battery.
8. Connect RED battery cable first to positive (+) battery terminal.
9. Connect BLACK grounding cable to negative (-) battery terminal.
10. Slide mount bracket back up over battery and retighten wingnuts.
11. Lower seat.

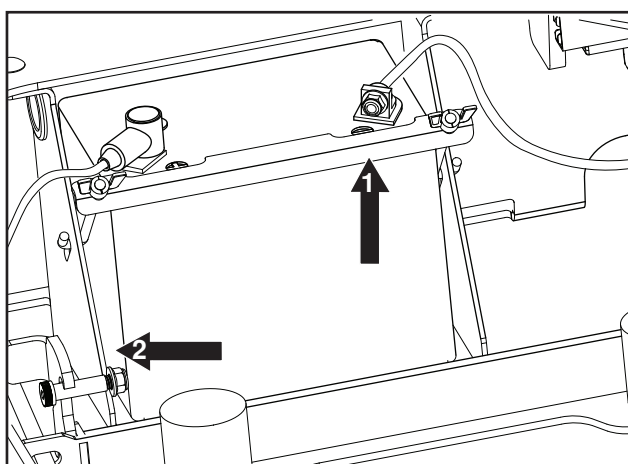

1. Mount bracket
2. Battery bracket

Battery cleaning and installation

8065-020

MAINTENANCE

Safety System

This machine is equipped with a safety system that prevents starting or driving under the following conditions.

The engine can only be started when:

- The mower deck is disengaged.
- The steering controls are in the outer, locked neutral position.
- The parking brake is on.

Make daily inspections to ensure that the safety system works by attempting to start the engine when one of the conditions is not met. Change the conditions and try again.

If the machine starts when one of these conditions is not met, turn the machine off and repair the safety system before using the machine again.

Make sure the engine stops when the park brake is not engaged and the operator leaves the seated position.

Check that the engine stops if the mower blades are engaged and the driver temporarily moves off the driver's seat.

Tire Pressures

Fill tire pressures to 15 psi / 103 kPa / 1 bar.

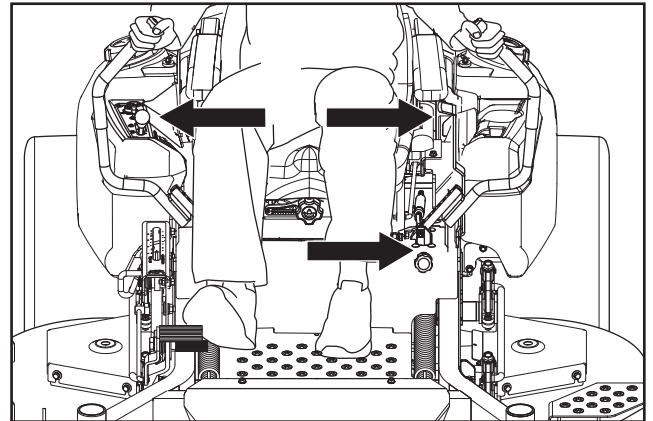

8065-021

Conditions for starting

IMPORTANT INFORMATION

To be able to drive, the driver must sit in the seat and release the parking brake before the steering controls can be moved into the neutral position, otherwise the engine will stop.

IMPORTANT INFORMATION

DO NOT add any type of tire liner or foam fill material to the drive tires. Excessive loads created by foam filled tires will cause premature failures.
Only use O.E.M. specified tires.

Parking Brake

Visually check that no damage is found on the lever, links, or switch belonging to the parking brake. Perform a standstill test and check that there is sufficient braking action.



WARNING!

Faulty adjustment result in reduced braking ability and can cause an accident.

IMPORTANT INFORMATION

The machine must be standing still when applying the parking brake.

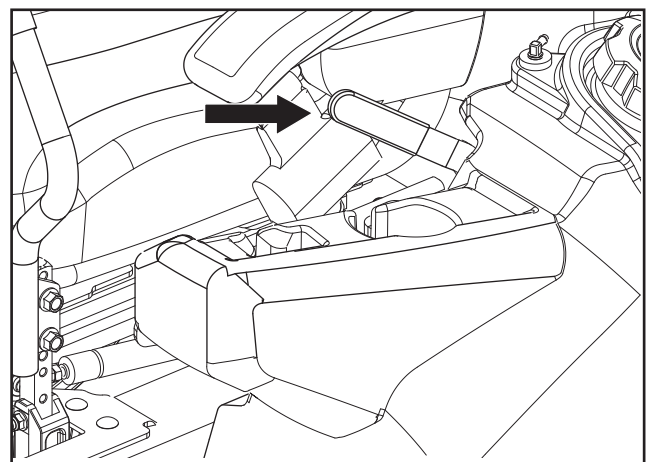

8065-006

Parking brake

MAINTENANCE

Deck Belt

Deck Belt Removal

Park on a level surface. Apply park brake. Lower the deck into the lowest cutting position.

1. Remove foot plate and belt shields.
2. Remove any dirt or grass that may have accumulated around the cutter housings and entire deck surface.
3. With a ½" breaker bar and using the square opening in the idler arm, shift the arm counter clockwise to relieve the tension on the belt.
4. Carefully roll the belt over the top of the cutter housing pulleys.
5. Remove the belt guide hardware with a ½" wrench and set belt guide aside.
6. Remove the belt from around the electric clutch on the engine shaft.

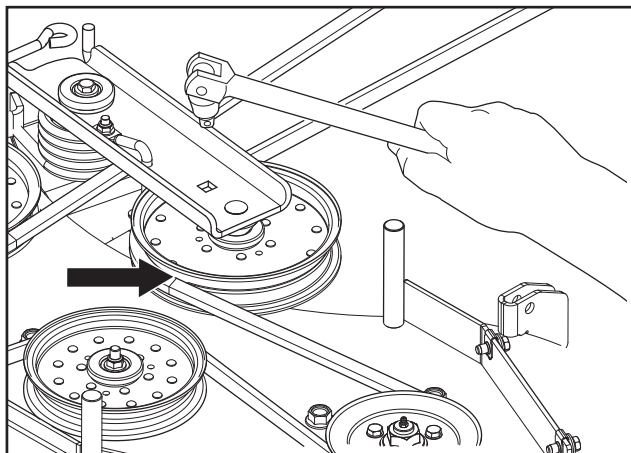

8065-040

Release the belt tension

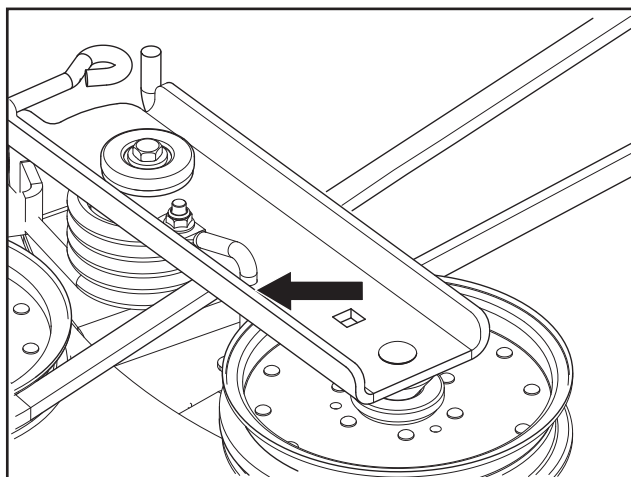

8065-046

Remove belt guide

Deck Belt Installation

NOTE: For ease in installing the deck belt, refer to the routing decal on the cutting deck.

1. Place the belt around all the pulleys except the center spindle pulley.
2. With a ½" breaker bar, shift the idler arm counter clockwise. When there is enough slack, slip the belt onto the center spindle pulley.
3. Reinstall the belt guide removed in Step 5 above.
4. Double check belt routing to make sure it matches the routing decal, and that the belt does not have any twist. Correct if needed.

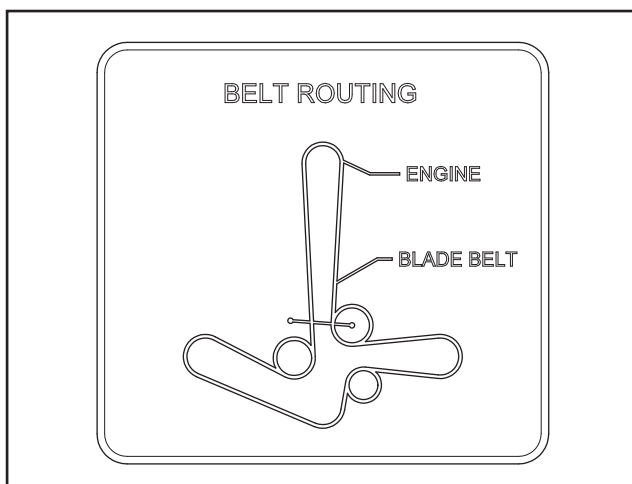

8065-047

Refer to belt routing decal

MAINTENANCE

5. Adjust belt tension by turning the eyebolt until there is approximately 2.2 cm - 2.5 cm ($\frac{7}{8}$ " - 1") of threads showing outside the nut.
6. Belt tension should be set to 81.3 - 95 Nm (60-70 lbs).
7. Replace belt shields on both mandrel housings and secure with fasteners.

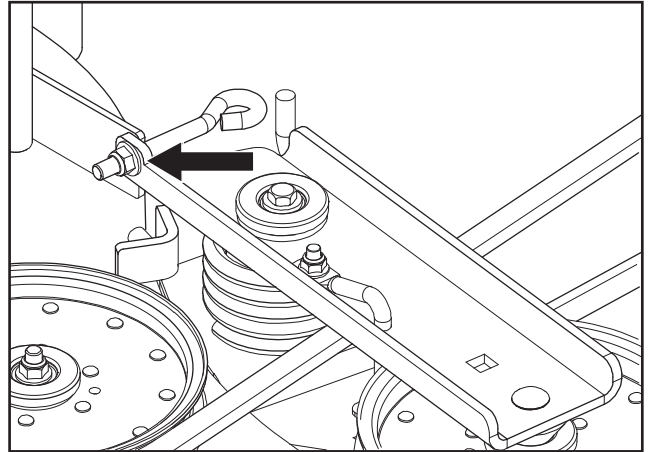

8065-054

Adjust belt tension

Pump Belt

The belts are not adjustable. Replace belts if they begin to slip from wear.

Replacing Pump Belt

Park the mower on a level surface. Engage the parking brake.

Belt Removal

1. Remove the deck belt (see *Deck Belt Removal* in this section of the manual).
2. Remove clutch stop to access the belt.
3. Disconnect clutch wire.
4. With a $\frac{1}{2}$ " breaker bar and using the square opening in the idler arm, shift the arm to create slack in the belt.
5. Remove belt from the engine and pump pulleys.

Belt Installation

1. Wrap the belt around the engine pulley.
2. Wrap the belt around the left pump pulley.
3. Route the belt around the inside of the idler pulley.
4. With a $\frac{1}{2}$ " breaker bar and using the square opening in the idler arm, shift the arm to create slack in the belt.
While holding the idler back with the breaker bar, wrap the belt around the right pump pulley.
5. Replace and secure clutch stop.
6. Reinstall the deck belt. (See *Deck Belt Installation* in this section of the manual).

V-belts

Check every 100 hours of operation. Check for severe cracking and large nicks.

NOTE: The belt will show some small cracks in normal operation.

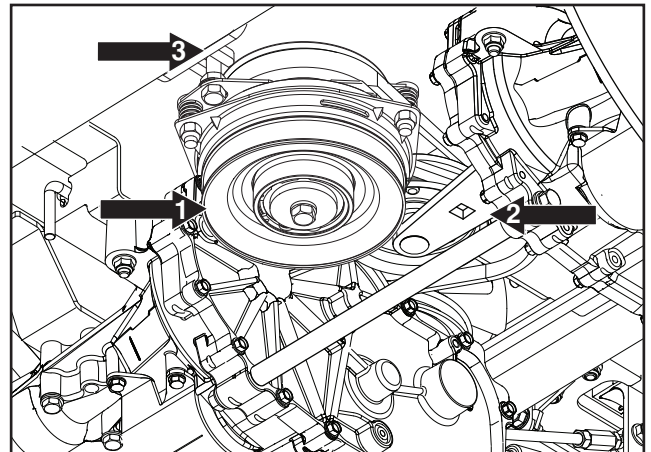

8068-092

1. Electric clutch
2. Idler release placement
3. Clutch stop

Pump belt removal

MAINTENANCE

Cutting Blades

To attain the best mowing effect, it is important that blades are well sharpened and not damaged.

Replace blades that have been bent or cracked when hitting obstacles.

Let the service workshop decide whether a blade with large nicks can be repaired/ground or must be replaced. Balance the blades after sharpening.

Check the blade mounts.

Blade Replacement



WARNING!

Blades are sharp. Protect your hands with gloves and/or wrap blades with a heavy cloth when handling.



1. Remove blade bolt by turning counterclockwise.
2. Install new or resharpened blade with stamped GRASS SIDE facing towards ground/grass (down) or THIS SIDE UP facing deck and spindle housing.
3. Install and tighten blade bolt securely.
4. Torque blade bolt to 122 Nm (90 ft-lbs).

IMPORTANT INFORMATION

Special blade bolt is heat treated.

Replace with a Husqvarna bolt if required.

Do not use lower grade hardware than specified.

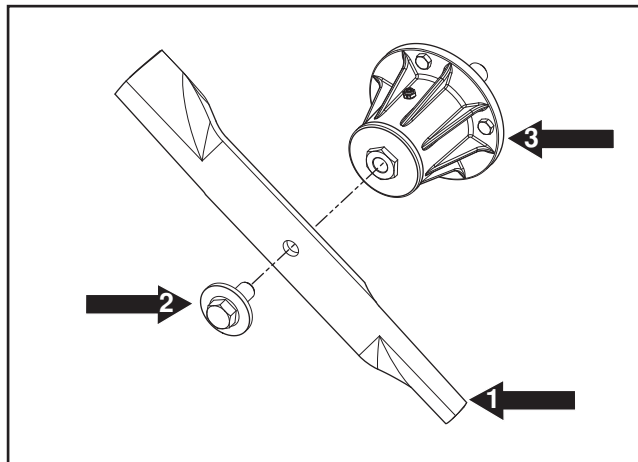

8058-013

1. Blade
 2. Blade bolt (special)
 3. Spindle housing
- Blade attachment*

IMPORTANT INFORMATION

The sharpening of blades should be carried out by an authorized service workshop.

MAINTENANCE

Adjusting the Mower Deck

Leveling Deck

Adjust the deck while the mower is on a level surface. Make sure the tires are inflated to the correct pressure. See *Tire Pressures* in **Maintenance** section. If tires are under or over inflated, the deck cannot be properly adjusted. Faulty mower deck adjustments will cause an uneven mowing result.

Four bolts control the height and pitch of the mower deck. The deck should be adjusted slightly higher in the rear.

NOTE: To insure accuracy of leveling procedure, mower deck drive belt must be installed prior to leveling the deck.

1. Wear heavy gloves. Turn each outer blade tip to align the deck in a side-to-side manner.
2. Measure from the floor surface up to the bottom of the blade tip on the discharge side of the mower deck. Record this measurement. Move to the opposite side; check that measurement is the same. If adjustment is required, use the nuts to adjust the right and left side eyebolts up or down until both side-to-side measurements are equal. Record measurement.
3. Turn both outer blades to align with the deck in front-to-rear manner. Reposition rear mounting eyebolts up or down until rear blade tips are positioned 0.32 cm - 0.95 cm ($\frac{1}{8}$ " to $\frac{3}{8}$ ") higher in the rear than the front blade tips.
4. Confirm measurements once again. The blade tip height should be equal side-to-side. In the rear, blade tips should be 0.32 cm - 0.95 cm ($\frac{1}{8}$ " to $\frac{3}{8}$ ") higher than the front measurement. In the front, blade tips should be equal from side-to-side.

NOTE: This will place the mower deck in a standard measurement position. Additional adjustment may be required to achieve desired cut for the type of grass or conditions being mowed.



WARNING!

Blades are sharp. Protect your hands with gloves and/or wrap blades with a heavy cloth when handling.

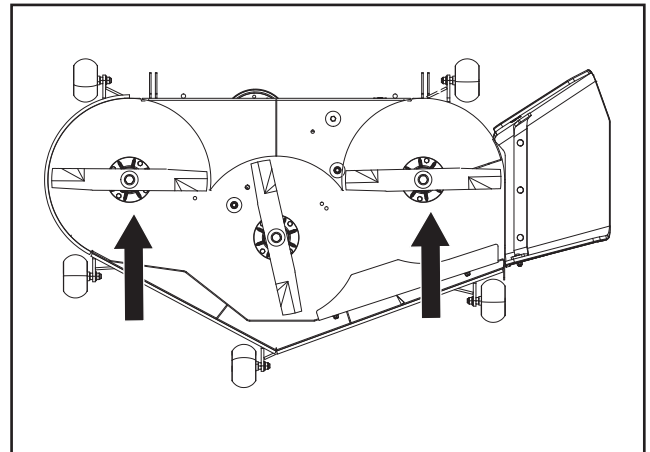

8065-093

Align blades side-to-side to begin measurements

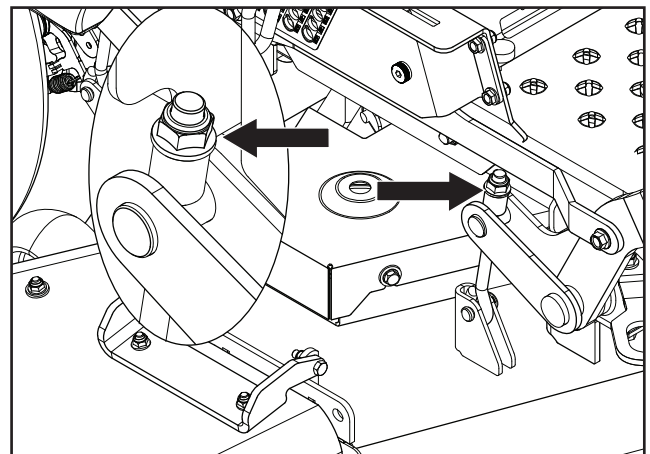

8065-100

Level the mower deck

MAINTENANCE

Anti-scalp Rollers

Anti-scalp rollers keep the deck in the proper position to help prevent scalping in most terrain conditions. Do not adjust the rollers to support the deck.

Rollers are properly adjusted when they are just slightly off of the ground when the deck is at the

IMPORTANT INFORMATION

Adjust anti-scalp rollers with the mower on a flat level surface.

desired cutting height in the operating position.

The anti-scalp rollers can be set in three positions:

- Upper position 25 to 63 mm (1 to 2½") grass.
- Middle position 63 to 102 mm (2½" to 4") grass.
- Lower position 102 to 127 mm (4" to 5") grass.

The rollers should be approximately 6.5 mm (¼") from ground. Do not adjust the rollers to support the deck.

IMPORTANT INFORMATION

To avoid deck damage, the anti-scalp rollers must not be adjusted to support the deck.

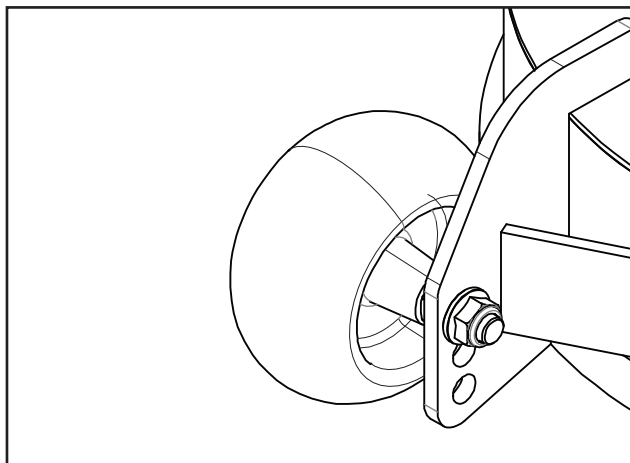

8065-094

Anti-scalp rollers

Caster Wheels

Check every 200 hours. Check that wheels rotate freely.

Removal and Installation

Remove nut and caster bolt. Pull the wheel out of the fork. Install in reverse order. Tighten caster bolt. Torque to 61 Nm (45 ft-lbs), then back nut off ½ turn.

NOTE: Tire should rotate freely but axle spacers should not. If wheels do not rotate freely take the unit to the dealer for service.

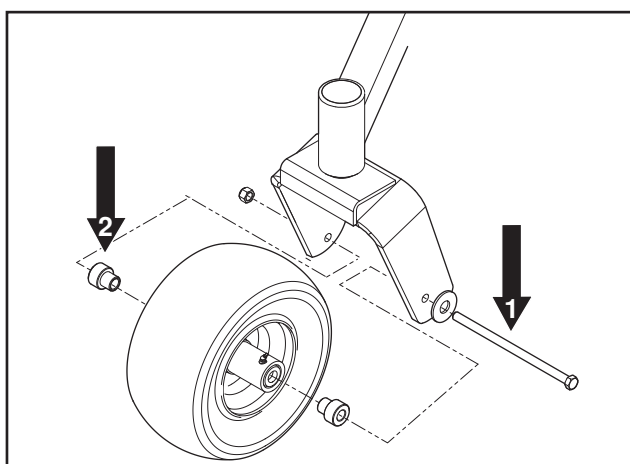

8065-030

1. Caster bolt
2. Axle spacer
Caster wheel

MAINTENANCE

Hardware

Check daily. Inspect the entire machine for loose or missing hardware.

Cleaning

Regular cleaning and washing, especially under the mower deck, will increase the machine's life-span. Make it a habit to clean the machine directly after use (after it is cooled), before the dirt sticks.

Do not spray water on the top of the mower deck. Use compressed air to clean the top side of mower deck. Regularly clean deck and underside of the deck with normal water pressure. Do not use a high pressure washer or steam cleaner. Avoid spraying engine and electrical components with water.

Do not rinse hot surfaces with cold water. Let unit cool before washing.



CAUTION

Use protective glasses when cleaning and washing.

ZT-3400 Powertrain

IMPORTANT INFORMATION

Any servicing dealer attempting a warranty repair must have prior approval before conducting maintenance of a Hydro-Gear® product, unless the servicing dealer is a current Authorized Hydro-Gear Service Center.

Regular external maintenance of the ZT-3400 Powertrain™ should include the following:

1. Check oil level in expansion tanks. When the engine is cold, the tanks should be at the FULL COLD level.
2. Inspect the vehicle drive belt, idler pulley(s), and idler spring(s). Insure that no belt slippage can occur. Slippage can cause low input speed to the transmission.
3. Inspect the transmission cooling fan for broken or bent blades. Remove any obstructions such as grass clippings, leaves or dirt.
4. Inspect the parking brake and vehicle linkage to insure proper action and adjustment of the parking brake.
5. Inspect the vehicle control linkage to the directional control arm on the transaxle. Also, make sure the control arm is securely fastened to the trunnion arm of the transaxle.
6. Inspect the bypass mechanism on the transaxle and unit linkage to make sure it rotates and releases fully.

LUBRICATION

Lubrication Schedule

12/12	1/52	1/365		50h	250h	500h	
				5			
				6			
				*			

8065-095

12/12 Every year 1/52 Every Week 1/365 Every day	Lubricate with grease gun	Filter change
	Oil change	Level check

* Change hydraulic drive filters.

▲ Change engine oil every 50 hours.

General

Remove the ignition key to prevent unintentional movements during lubrication.

When lubricating with an oil can, it must be filled with engine oil.

When lubricating with grease, unless otherwise stated, use high grade molybdenum disulphide grease.

For daily use, the machine should be lubricated twice weekly.

Wipe away excess grease after lubrication.

It is important to avoid getting lubricant on the belts or the drive surfaces on the belt pulleys. Should this happen, attempt to clean them with spirits. If the belt continues to slip after cleaning, it must be replaced. Gasoline or other petroleum products must not be used to clean belts.

LUBRICATION

Wheel and Deck Zerks

Use only good quality bearing grease. Grease from well-known brand names (petrochemical companies, etc.) usually maintains a good quality.

Front Wheel Mount

Remove dust cap to expose zerk. Lubricate with a grease gun until the grease is forced out around the top washer.

Front Wheel Bearings

Lubricate 3-4 strokes with a grease gun on each set of wheel bearings.

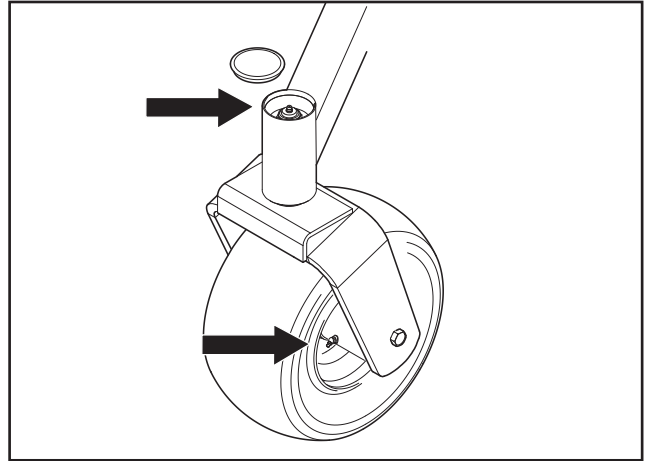

8065-032

Lubricating front wheels

Deck Spindle

Lower the cutting deck completely. If a grease gun without rubber hose is used, the foot plate must be removed. Lubricate with a grease gun, 2-3 strokes per spindle.

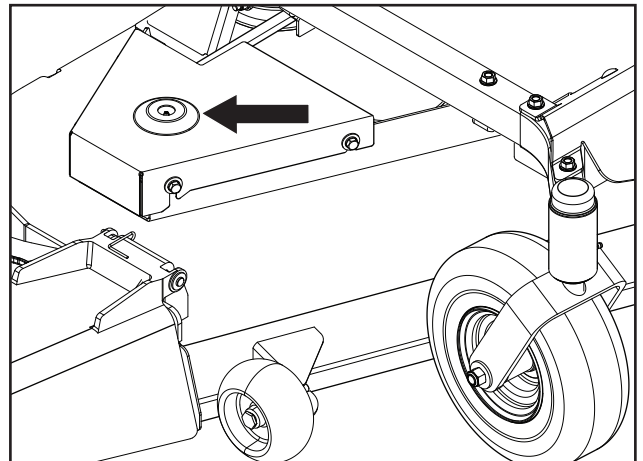

8058-131

Deck spindle

LUBRICATION

Transaxle Fluid Change

This transaxle is designed with an external filter for ease of maintenance. To ensure constant fluid quality levels and longer life, an oil filter change interval of every 200 hours is recommended.

The following procedure is performed with the transaxles installed in the mower and the mower on level ground. Apply the pump release valve for each transaxle and set the parking brake.

1. Remove the three filter guard screws and filter guard. Clean any loose debris from around the perimeter of the filter. See illustration.
2. Place an oil drain pan beneath the oil filter that is 31 cm (12") or more in diameter and has an optimal 7.5 liter (8 qt.) capacity. Remove the oil filter from the transaxle.

Drain old oil filters of all free-flowing oil prior to disposal. Place used oil in appropriate containers and dispose of it in accordance with laws in your area.

3. After the oil has drained, wipe the filter base surface and apply a film of new oil to the gasket of the replacement filter.
4. Install the new filter by hand, turning it three-quarters to one full turn after the filter gasket contacts the filter base surface.
5. Reinstall the filter guard. Torque screws to 7.3 Nm (65 in./lbs.) each.
6. Repeat steps on the opposite side.
7. Drain old oil filters of all free flowing oil prior to disposal. Place used oil in appropriate containers and dispose of it in accordance with laws in your area.
8. Remove the top port plug (see illustration) from the left side and right side of the transaxles prior to filling with oil. This will allow the transaxles to vent during oil fill.
9. Remove the cap from the transaxles' expansion tank located on the vehicle frame.

10. Fill with SAE 20W-50 motor oil until oil appears just at the bottom of each transaxles' top port (approximately 2 quarts per transaxle, 4 quarts total). Install the top port lug into each transaxle as the oil level reaches the port.
11. Install and torque the top port plugs to 20.3 Nm (180 in./lbs).
12. Continue to fill the transaxles through the expansion tank until the FULL COLD line is reached. This will take approximately 0.68 additional liters (23 ounces).
13. Reinstall the expansion tank cap by hand. Do not overtighten.

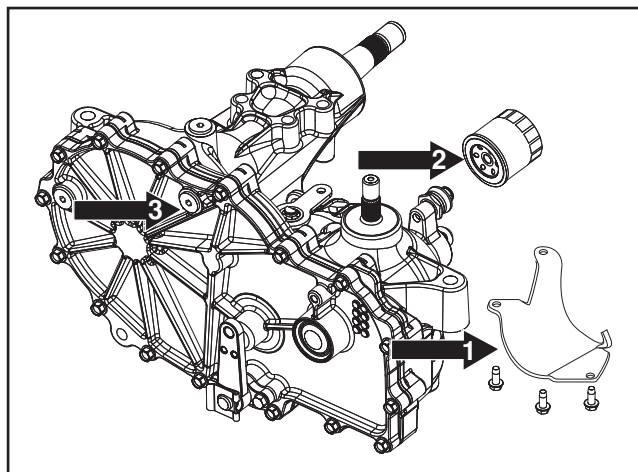

8019-010

1. Filter guard
 2. Transaxle filter
 3. Top port plug
- ZT-3400 filter change*

TROUBLESHOOTING GUIDE

Problem / Cause

Engine will not start

- Blade switch is engaged
 - Steering controls are not locked in the neutral position
 - Parking brake is not activated
 - Battery is dead
 - Contamination in the carburetor or fuel line
 - Fuel supply is closed or the tap for the fuel tank is in the wrong position
 - Clogged fuel filter or fuel line
 - Faulty ignition system
-

Starter does not turn the engine over

- Dead battery
 - Poor contacts on the battery terminal cable connections
 - Fuse blown
 - Ignition system faulty
 - Fault in the starter safety circuit See **Safety System** in the **Maintenance** section
-

Engine runs rough

- Faulty carburetor
 - Choke control is pulled out with warm engine
 - Clogged fuel filter or jet
 - Clogged ventilation valve on the fuel cap
 - Fuel tank nearly empty
 - Fouled spark plug
 - Spark plug is loose
 - Rich fuel mixture or fuel-air mixture
 - Water in the fuel (gasoline)
 - Clogged air filter
-

Engine seems weak

- Clogged air filter
- Fouled spark plugs
- Carburetor incorrectly adjusted

TROUBLESHOOTING GUIDE

Problem / Cause

Machine vibrates

- Blades are loose
 - Blades are incorrectly balanced
 - Engine is loose
-

Engine overheats

- Clogged air intake or cooling fins
 - Engine overloaded
 - Poor ventilation around engine
 - Defective engine speed regulator
 - Too little or no oil in the engine
 - Fouled spark plug
-

Battery not charging

- Poor contact with battery terminal cable connectors
 - Charging lead is disconnected
-

Machine moves slowly, unevenly, or not at all

- Parking brake on
 - Bypass valve on pump open
 - Drive belt for the transmission gears slack or has come off
 - Air in hydraulic system
-

Mower deck not engaging

- Drive belt for the mower deck has come loose
 - Contact for the electromagnetic coupling has loosened
 - Blade switch is faulty or has come loose, from the cable contact
 - Fuse has blown
 - Carburetor incorrectly adjusted
-

Hydraulic drive leaks oil

- Damaged seals, housing, or gaskets
 - Air trapped in hydraulic system
-

Uneven mowing results

- Unequal tire pressure on the left and right sides
- Bent blades
- Suspension for the mower deck is uneven
- Blades are dull
- Driving speed too high
- Grass is too long
- Grass collected under the mower deck

STORAGE

Winter Storage

The machine should be readied for storage at the end of the mowing season, or if it will not be in use for more than 30 days.

Fuel allowed to stand for long periods of time (30 days or more) can leave sticky residues that can plug the carburetor and disrupt engine function.

Fuel stabilizers are an acceptable option as regards to the sticky residues that can occur during storage.

Add stabilizer to the fuel in the tank or in the storage container. Always use the mixing ratios specified by the manufacturer of the stabilizer. Run the engine for at least 10 minutes after adding the stabilizer so that it reaches the carburetor. Do not empty the fuel tank and the carburetor if a stabilizer has been added.



WARNING!

Never store an engine with fuel in the tank indoors or in poorly ventilated spaces where fuel vapor can come in contact with open flames, sparks, or a pilot light such as in a boiler, hot water tank, clothes drier, etc. Handle the fuel with care. It is very flammable and can cause serious personal injury and property damage. Drain the fuel outdoors, into an approved container. Store the fuel away from open flame or any source of ignition. Never use gasoline for cleaning. Use a degreaser and warm water.

To ready the machine for storage, follow these steps:

1. Thoroughly clean the machine, especially under the mower deck. Touch up damage to the paint and spray a thin layer of oil on the underside of the mower deck to avoid corrosion.
2. Inspect the machine for worn or damaged parts and tighten any nuts or screws that may have become loose.
3. Change the engine oil; dispose of properly.
4. Empty the fuel tanks or add a fuel stabilizer. Start the engine and allow it to run until the carburetor is drained of fuel or the stabilizer has reached the carburetor.
5. Remove the spark plug and pour about a tablespoon of engine oil into the cylinder. Turn over the engine so that the oil is evenly distributed and then refit the spark plug.
6. Lubricate all grease zerks, joints, and axles.
7. Remove the battery. Clean, charge, and store the battery in a cool place, but protect it from direct cold.
8. Store the machine in a clean, dry place and cover it for extra protection.

Service

When ordering spare parts, please specify the purchase year, model, type, and serial number.

Always use genuine Husqvarna spare parts.

An annual checkup at an authorized service workshop is a good way to ensure that the machine performs its best the following season.

WIRING DIAGRAM

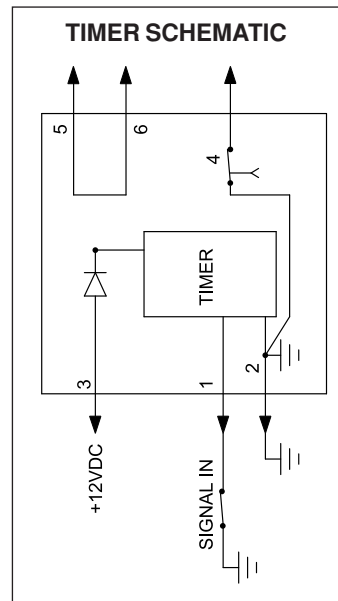
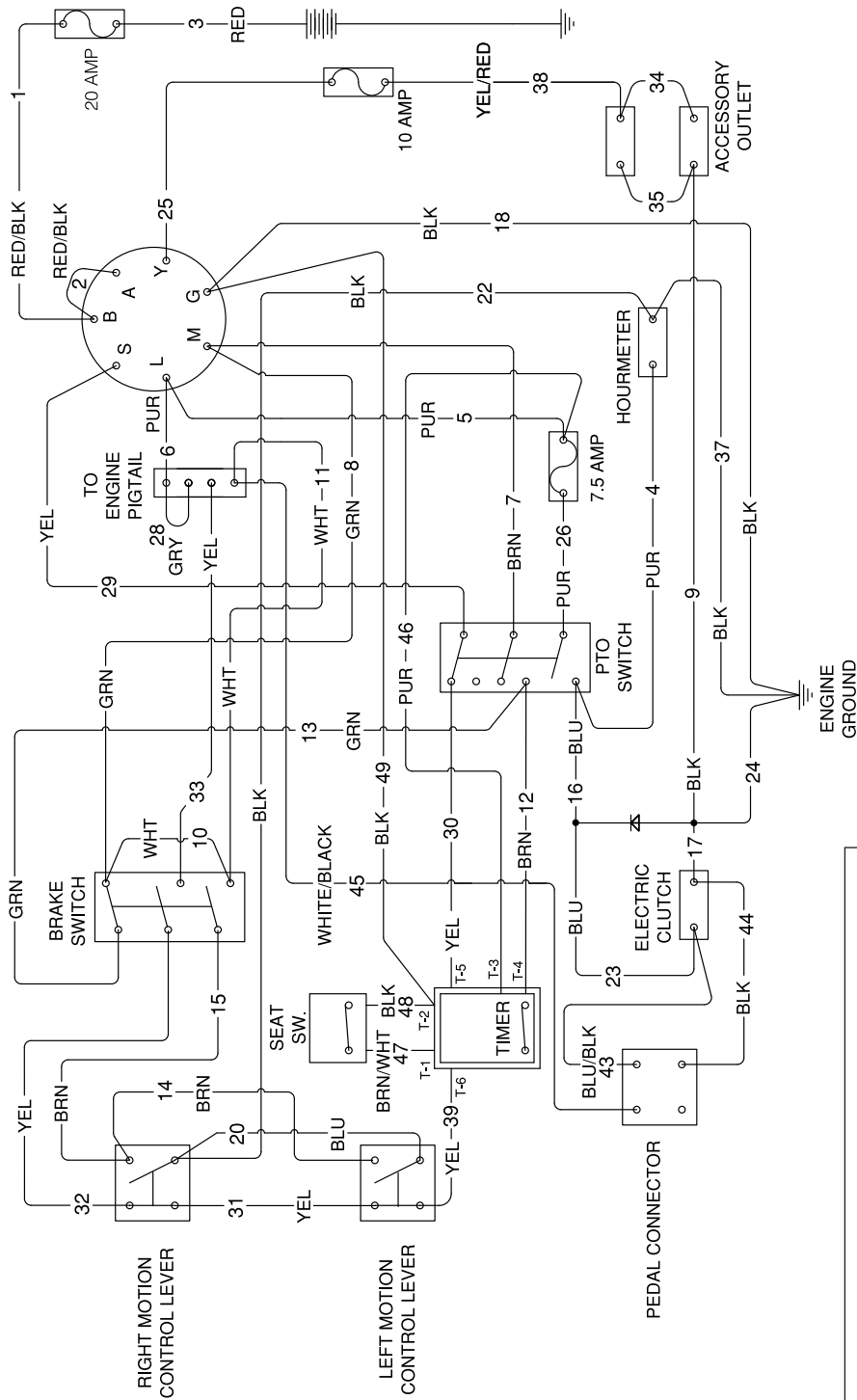

TECHNICAL DATA

Torque Specifications

Engine crankshaft bolt	50 ft/lb (67 Nm)	Standard $\frac{5}{16}$ " fasteners	18 ft/lb (25 Nm)
Deck pulley bolts	150 ft/lb (203 Nm)	Standard $\frac{3}{8}$ " fasteners	33 ft/lb (44 Nm)
Blade bolt	90 ft/lb (122 Nm)	Standard $\frac{7}{16}$ " fasteners	52 ft/lb (70 Nm)
Standard $\frac{1}{4}$ " fasteners	9 ft/lb (12 Nm)	Standard $\frac{1}{2}$ " fasteners	80 ft/lb (110 Nm)

Hex Head Cap Screws

The torque values shown should be used as a general guideline when specific torque values are not given.

U.S. Standard Hardware

Shank Size (Diameter in inches, fine or coarse thread)	Grade	SAE Grade 5		SAE Grade 8		Flangelock Screw w/Flangelock Nut	
	Size	ft./lbs	Nm	ft./lbs	Nm	ft./lbs	Nm
	$\frac{1}{4}$	9	12	13	18		
	$\frac{5}{16}$	18	24	28	38	24	33
	$\frac{3}{8}$	31	42	46	62	40	54
	$\frac{7}{16}$	50	68	75	108		
	$\frac{1}{2}$	75	102	115	156		
	$\frac{9}{16}$	110	150	165	224		
	$\frac{5}{8}$	150	203	225	305		
	$\frac{3}{4}$	250	339	370	502		
	$\frac{7}{8}$	378	513	591	801		
	$1\frac{1}{8}$	782	1060	1410	1912		

** Grade 5 - Minimum commercial quality (lower quality not recommended)

Metric Standard Hardware

Shank Size (Diameter in millimeters, fine or coarse thread)	Grade	Grade 8.8		Grade 10.9		Grade 12.9	
	Size	ft./lbs	Nm	ft./lbs	Nm	ft./lbs	Nm
	M4	1.5	2	2.2	3	2.7	3.6
	M5	3	4	4.5	6	5.2	7
	M6	5.2	7	7.5	10	8.2	11
	M7	8.2	11	12	16	15	20
	M8	13.5	18	18.8	25	21.8	29
	M10	24	32	35.2	47	43.5	58
	M12	43.5	58	62.2	83	75	100
	M14	70.5	94	100	133	119	159
	M16	108	144	147	196	176	235
	M18	142	190	202	269	242	323
	M20	195	260	275	366	330	440
	M22	276	368	390	520	471	628
	M24	353	470	498	664	596	794
M27	530	707	474	996	904	1205	

TECHNICAL DATA

P-ZT26 CE / 966791901	
Engine	
Manufacturer	Kawasaki ¹⁾
Type	FX730V
Power	26 HP ²⁾
Lubrication	Pressure w/ Oil Filter
Fuel	Min 87 octane unleaded (Max ethyl alcohol 10%, Max MTBE 15%)
Fuel tanks capacity	41.6 liters / 11 gallons
Cooling	Air cooled
Air filter	Heavy duty canister
Alternator	12v 15 amp @ 3600 rpm
Starter	Electric
Transmission	
Transmission	ZT-3400
Speed and direction controls	Dual levers, foam gripped
Speed forward	0-10 mph - 0-16.1 Km/h
Speed reverse	0-5 mph - 0-8 Km/h
Brakes	Internal Cog
Front caster tires, smooth tread	13 x 6.5-6
Rear tires, turf pneumatic	23 x 10.5-12
Tire pressures	15 PSI / 103 kPa / 1 bar

¹⁾ See the Engine Manufacturer's manual for engine specifications.

²⁾ The power rating of the engines indicated is the average net power output (at specified rpm) of a typical production engine for the engine model measured to SAE standard J1349/ISO1585. Mass production engines may differ from this value. Actual power output for the engine installed in the final machine will depend on the operating speed, environmental conditions and other variables.

TECHNICAL DATA

P-ZT26 CE / 966791901	130 cm Combi Deck	132 cm Deck	155 cm Deck
Frame			
Cutting Width	132 cm / 52"	132 cm / 52"	155 cm / 61"
Cutting Height	2.5-14 cm / 1"-5½"	2.5-14 cm / 1"-5½"	2.5-14 cm / 1"-5½"
Uncut Circle	0	0	0
Number of Blades	3	3	3
Blade Length	41.3 cm / 16¼"	46 cm / 18"	53 cm / 21"
Anti-scalp Rollers	4 adjustable	5 adjustable	5 adjustable
Sprung Seat	Suspension	Suspension	Suspension
Hinged Arm Rests	Yes	Yes	Yes
Hour Meter	Yes	Yes	Yes
Blade Engagement	Ogura 150	Ogura 150	Ogura 150
Deck Construction	11 gauge	11 gauge	11 gauge
Productivity	15,783 m ² /h 3.9 acres/h	16,997 m ² /h 4.2 acres/h	19,830 m ² /h 4.9 acres/h
Dimension			
Weight	472 kg / 1040 lbs	486 kg / 1070 lbs	500 kg / 1100 lbs
Base Machine Length	205 cm / 81"	205 cm / 81"	205 cm / 81"
Base Machine Height	127 cm / 50"	127 cm / 50"	127 cm / 50"
Base Machine Width	119 cm / 47"	130 cm / 51"	130 cm / 51"
Overall Width	138 cm / 54½"	136 cm" / 53½"	159 cm / 62½"
Overall Width, Chute Down	-	166 cm / 65½"	189 cm / 74½"
Overall Height, ROPS Up	184 cm / 72½"	184 cm / 72½"	184 cm / 72½"
Vibrations ¹⁾			
Steering Lever	2.60 m/s ²	2.12 m/s ²	2.73 m/s ²
Seat	0.11 m/s ²	0.16 m/s ²	0.15 m/s ²
Noise Emissions ²⁾			
Sound Lever at Operator's Ear	101 dB(A)	100 dB(A)	102 dB(A)
Guaranteed Noise Level	105 dB(A)	105 dB(A)	105 dB(A)
Measured Noise Level	103 dB(A)	105 dB(A)	102 dB(A)

¹⁾ *Vibration level according to EN 836. Reported data for vibration level has a typical statistical dispersion (standard deviation) of 0.2 m/s² (steering levers) and 0.8 m/s² (seat).*

²⁾ *Sound pressure level according to EN 836. Reported data for noise pressure level has a typical statistical dispersion (standard) of .08 dB(A). If the machine can be equipped with different cutting decks, the noise pressure levels are stated in order starting from the cutting deck with the smallest cutting width.*

CONFORMITY CERTIFICATES

Conformity Certificates For Model:

**966791901 / P-ZT26 CE Zero Turn
Rider**

USA requirements

Labels are placed on the engine and/or in the engine compartment stating that the machine will fulfill the requirements. This is also applicable to special requirements for any of the states, (California emission rules etc.). Do not remove any of these labels. Certificates can also be supplied with the machine at delivery or written in the Engine manual. Take care of them as they are valuable documents.

EU Declaration of Conformity Information

Only applicable to European versions

See the Declaration of Conformity Certificate for additional information.

Husqvarna AB, Orangeburg, SC, USA declares under sole responsibility that the machine types stated on page 1 of this manual, from 2012's serial numbers and onwards (the year is clearly stated in plain text on the rating plate with subsequent serial number), complies with the requirements of the COUNCIL'S DIRECTIVES:

- of May 17, 2006 "relating to machinery" 2006/42/EC, annex IIA.
- of December 15, 2004 "relating to electromagnetic compatibility" 2004/108/EC, and applicable supplements.
- of May 8, 2000 "relating to the emission of noise to surroundings" 2000/14/EC.

The following harmonised standards have been applied: EN ISO 12100-2, EN836.

Business Name and Address:

Husqvarna
172 Old Ellore Rd
Orangeburg, SC 29115 USA

Notified Body:

SNCH, 11 Route de Luxembourg, L-5230 Sandweiler, has issued reports regarding the assessment of conformity according annex VI of the COUNCIL'S DIRECTIVE of May 8, 2000 "relating to the noise emissions in the environment" 2000/14EC.

SERVICE JOURNAL

Action	Date, mtr reading, stamp, sign
Delivery Service	
Charge and connect the battery	<input type="checkbox"/>
Adjust the tire pressure of all wheels to 15 PSI (1 bar)	<input type="checkbox"/>
Connect the contact box to the cable for the seat's safety switch	<input type="checkbox"/>
Check hydraulic oil level	<input type="checkbox"/>
Check hydraulic hoses for kinking or leaks	<input type="checkbox"/>
Check neutral position	<input type="checkbox"/>
Fill with fuel and open the fuel shut off valve	<input type="checkbox"/>
Start the engine	<input type="checkbox"/>
Check that there is drive to both wheels	<input type="checkbox"/>
Check mower deck pitch and adjustment	<input type="checkbox"/>
Check:	
Safety switch for the parking brake	<input type="checkbox"/>
Safety switch for the mower deck	<input type="checkbox"/>
Safety switch in the seat	<input type="checkbox"/>
Safety switch in the steering controls	<input type="checkbox"/>
Parking brake functionality and adjustment	<input type="checkbox"/>
Driving forward	<input type="checkbox"/>
Driving backward	<input type="checkbox"/>
Engaging the blades	<input type="checkbox"/>
Check the idle speed	<input type="checkbox"/>
Check the engine high idle speed	<input type="checkbox"/>
Inform the customer about:	
The need and advantages of following the service schedule	<input type="checkbox"/>
The need and advantages of leaving the machine for service	<input type="checkbox"/>
The effects of service and maintaining a service journal on the machine's resale value	<input type="checkbox"/>
Application areas for mulching	<input type="checkbox"/>
Fill in the sales papers, etc.	
Delivery service has been carried out No remaining notes Certified:	

SERVICE JOURNAL

Action	Date, mtr reading, stamp, sign
After 10 hours	
Change the engine oil	<input type="checkbox"/>
Change the oil filter	<input type="checkbox"/>
Inspect hydraulic hoses	<input type="checkbox"/>
Inspect hydraulic belt	<input type="checkbox"/>
Inspect hydraulic filter	<input type="checkbox"/>
Check neutral position	<input type="checkbox"/>
Check safety system	<input type="checkbox"/>
Check seat belt	<input type="checkbox"/>
Check ROPS	<input type="checkbox"/>
Check fuel system for leaks	<input type="checkbox"/>
Inspect safety guards and shields	<input type="checkbox"/>
Check brake adjustment	<input type="checkbox"/>

SERVICE JOURNAL

Action	Date, mtr reading, stamp, sign
Daily Service	
Clean debris from mower	<input type="checkbox"/>
Check engine oil level	<input type="checkbox"/>
Check the tire pressures	<input type="checkbox"/>
Check underside of deck	<input type="checkbox"/>
Inspect deck pulleys	<input type="checkbox"/>
Check/clean the engine's cooling air intake	<input type="checkbox"/>
Check safety system	<input type="checkbox"/>
Check seat belt	<input type="checkbox"/>
Check ROPS	<input type="checkbox"/>
Check fuel system for leaks	<input type="checkbox"/>
Inspect safety guards and shields	<input type="checkbox"/>
Check brake adjustment	<input type="checkbox"/>

SERVICE JOURNAL

Action	Date, mtr reading, stamp, sign
50-Hour Service	
Clean debris from mower	<input type="checkbox"/>
Check engine oil level	<input type="checkbox"/>
Check the tire pressures	<input type="checkbox"/>
Check underside of deck	<input type="checkbox"/>
Inspect deck pulleys	<input type="checkbox"/>
Check/clean the engine's cooling air intake	<input type="checkbox"/>
Check safety system	<input type="checkbox"/>
Check seat belt	<input type="checkbox"/>
Check ROPS	<input type="checkbox"/>
Check fuel system for leaks	<input type="checkbox"/>
Inspect safety guards and shields	<input type="checkbox"/>
Check brake adjustment	<input type="checkbox"/>

SERVICE JOURNAL

Action	Date, mtr reading, stamp, sign
250-Hour Service	
Grease fittings (caster pivots and caster wheels)	<input type="checkbox"/>
Inspect dampers	<input type="checkbox"/>
Inspect frame	<input type="checkbox"/>
Inspect throttle and choke cables	<input type="checkbox"/>
Inspect hardware	<input type="checkbox"/>
Check the tire pressures	<input type="checkbox"/>
Change the engine oil and filter	<input type="checkbox"/>
Change air filter	<input type="checkbox"/>
Inspect spark plug	<input type="checkbox"/>
Inspect fuel filter	<input type="checkbox"/>
Check engine RPM	<input type="checkbox"/>
Clean underside of deck	<input type="checkbox"/>
Check blade pitch	<input type="checkbox"/>
Grease blade spindles	<input type="checkbox"/>
Inspect spindle bearings	<input type="checkbox"/>
Inspect deck belt and blades	<input type="checkbox"/>
Inspect idler arm bearings	<input type="checkbox"/>
Inspect deck idler pulleys	<input type="checkbox"/>
Inspect hydraulic filter	<input type="checkbox"/>
Inspect hydraulic drive belt	<input type="checkbox"/>
Inspect hydraulic hoses	<input type="checkbox"/>
Check neutral position	<input type="checkbox"/>
Inspect battery connections	<input type="checkbox"/>
Check safety system	<input type="checkbox"/>
Check seat belt	<input type="checkbox"/>
Check ROPS	<input type="checkbox"/>
Check fuel system for leaks	<input type="checkbox"/>
Inspect safety guards and shields	<input type="checkbox"/>
Check brake adjustment	<input type="checkbox"/>

SERVICE JOURNAL

Action	Date, mtr reading, stamp, sign
500-Hour Service	
Grease fittings (caster pivots and caster wheels)	<input type="checkbox"/>
Inspect dampers	<input type="checkbox"/>
Inspect frame	<input type="checkbox"/>
Inspect throttle and choke cables	<input type="checkbox"/>
Inspect hardware	<input type="checkbox"/>
Check the tire pressures	<input type="checkbox"/>
Change the engine oil and filter	<input type="checkbox"/>
Change air filter	<input type="checkbox"/>
Inspect spark plug	<input type="checkbox"/>
Inspect fuel filter	<input type="checkbox"/>
Check engine RPM	<input type="checkbox"/>
Clean underside of deck	<input type="checkbox"/>
Check blade pitch	<input type="checkbox"/>
Grease blade spindles	<input type="checkbox"/>
Inspect spindle bearings	<input type="checkbox"/>
Inspect deck belt and blades	<input type="checkbox"/>
Inspect idler arm bearings	<input type="checkbox"/>
Inspect deck idler pulleys	<input type="checkbox"/>
Change hydraulic oil level	<input type="checkbox"/>
Change hydraulic filter	<input type="checkbox"/>
Replace hydraulic drive belt	<input type="checkbox"/>
Inspect hydraulic hoses	<input type="checkbox"/>
Check neutral position	<input type="checkbox"/>
Inspect battery connections	<input type="checkbox"/>
Load test battery	<input type="checkbox"/>
Clean electrical connections	<input type="checkbox"/>
Inspect the clutch	<input type="checkbox"/>
Check safety system	<input type="checkbox"/>
Check seat belt	<input type="checkbox"/>
Check ROPS	<input type="checkbox"/>
Check fuel system for leaks	<input type="checkbox"/>
Inspect safety guards and shields	<input type="checkbox"/>
Check brake adjustment	<input type="checkbox"/>

SERVICE JOURNAL

Action	Date, mtr reading, stamp, sign
<p>At Least Once Each Year</p> <p>Clean the engine's cooling air intake</p> <p>Replace the air cleaner's pre-filter (foam)</p> <p>Replace the air filter's paper cartridge</p> <p>Change the engine oil</p> <p>Replace the engine oil filter</p> <p>Check/adjust the cutting height</p> <p>Check/adjust the parking brake</p> <p>Clean/Change the spark plugs</p> <p>Inspect spark plug</p> <p>Check the engine valve clearance</p>	<p><input type="checkbox"/></p> <p><input type="checkbox"/></p> <p><input type="checkbox"/></p> <p><input type="checkbox"/></p> <p><input type="checkbox"/></p> <p><input type="checkbox"/></p> <p><input type="checkbox"/></p> <p><input type="checkbox"/></p> <p><input type="checkbox"/></p> <p><input type="checkbox"/></p>



Original Instructions
115 46 25-26

2012-03-26