

Operator Manual

SG13B / 966042601 / 2009-03

Please read the operator's manual carefully and make sure you understand the instructions before using the machine.

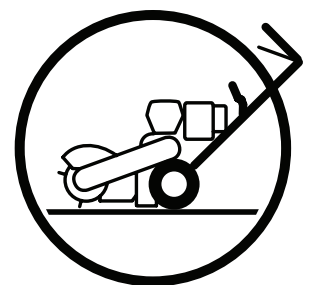

CONTENTS

INTRODUCTION.....	4	OPERATION	26
Good Service.....	4	Preparation	26
Serial Number.....	4	Starting The Engine.....	27
SYMBOLS AND DECALS	5	Handle Engine Switch.....	28
SAFETY	7	OP Grip Bar	28
General use	7	Starter Handle.....	28
Preparations	9	Throttle.....	28
Operating.....	10	Procedure	29
Movement/Transport.....	11	Operating On Hills	31
Storage	11	Transport	31
Children	11	Normal Shutdown	32
Fuel System.....	12	Emergency Shutdown.....	32
Maintenance	13	MAINTENANCE	33
PROTECTION EQUIPMENT	14	Maintenance Schedule	33
Personal Protection Equipment	14	Cyclone Filter.....	34
SET-UP	15	Air Filter	35
CONTROLS	18	Sludge Reservoir	36
Engine.....	19	Idle Adjustment	37
Speed Control Lever.....	19	Ignition System	38
Starter	20	Drive Belt	39
Starter Handle.....	20	Removing/Refitting Wheels	41
Fuel Valve.....	20	Brake Adjustment.....	41
Choke Control.....	20	Two Minute Rule	42
Air Filter	21	Cleaning.....	42
Spark Plug	21	LUBRICATION	43
Muffler.....	21	Engine Oil	44
Oil Dipstick.....	22	Throttle cable.....	45
Oil Drain.....	22	TROUBLESHOOTING	46
Fuel Tank	23	STORAGE.....	48
Fueling.....	23	Winter Storage.....	48
Centrifugal Clutch	23	Service.....	48
Operator Presence (OP) Grip Bar	24	TECHNICAL DATA.....	49
Throttle.....	24		
Control Panel On/Off Engine Switch.....	24		
Brake	25		
Handle Adjustment Bar	25		

INTRODUCTION

Congratulations

Thank you for purchasing a Husqvarna stump grinder. Through your confidence in us, you have chosen an exceptionally high quality product.

This manual is a valuable document. It describes your new Husqvarna machine. Read the manual carefully before attempting to use the machine. Following the instructions (use, service, maintenance, etc.) can considerably increase the life-span of your machine and even increase its resale value. Please contact your dealer for more information.

If you sell your Husqvarna machine, make sure to give the operator's manual to the new owner.

Use

The stump grinder is used to remove tree stumps. By moving the blade in lateral sweeping movements over the top and front of the stump, it is gradually chipped away. Read the chapter "Safety instructions" before you use the machine for the first time.

Insure your machine

Contact your insurance company to check on insurance coverage for your new machine. You should have all-inclusive insurance for liability, fire, damage and theft.

Good Service

Husqvarna's products are sold all over the world and only in specialized retail trade with complete service. This ensures that you as a customer receive only the best support and service. Before the machine was delivered it underwent inspection and was adjusted by your dealer. When you need spare parts or support in service questions, guarantee issues, etc., please consult the following professional:

This Operator's Manual belongs to machine with serial number:	Engine number:

Serial Number

The serial number can be found on the printed plate attached to the frame in front of engine. The plate includes the following information:

- The machine's type designation (MODEL).
- The machine's serial number (S/N).

Please state the type designation and serial number when ordering spare parts.

The engine's serial number is punched in the crankcase under the oil level guard.

The engine type is specified on the crankcase to the right of the oil level guard but also appears on the decal on the starter.

Please state these when ordering spare engine parts.

SYMBOLS AND DECALS

 **WARNING!**
Xxxx xxx xxxx xx xxxx x xxxx.

IMPORTANT INFORMATION
Xxxx xxx xxxx xx xxxx x xxxx.

Used in this publication to notify the reader of a risk of personal injury, particularly if the reader DOES NOT follow the instructions given in the manual.

Used in this publication to notify the reader of a risk of material damage, particularly if the reader DOES NOT follow the instructions given in the manual. Used also when there is a potential for misuse or misassembly.

Decals and machine-mounted instructions

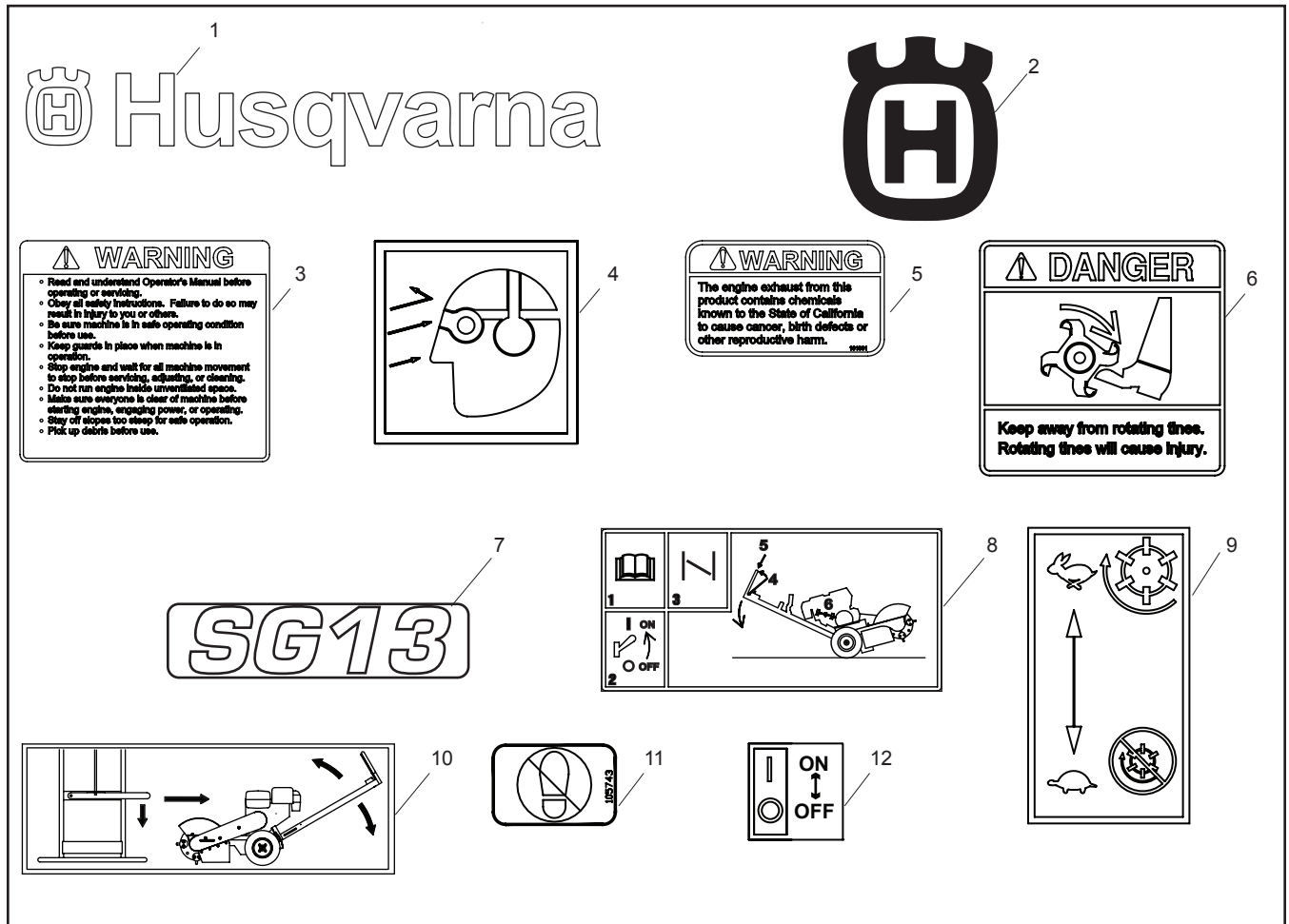

Missing or illegible decals must be replaced before using the machine.

- | | | | |
|----|--|-----|----------------------|
| 1. | Husqvarna logo | 7. | Model designation |
| 2. | Husqvarna Crown logo | 8. | Starting procedure |
| 3. | General precautions | 9. | Throttle |
| 4. | Use ear and eye protection | 10. | Handle adjustment |
| 5. | Exhaust warnings | 11. | No step |
| 6. | DANGER risk for injury from cutter blade | 12. | Handle engine switch |

SYMBOLS AND DECALS

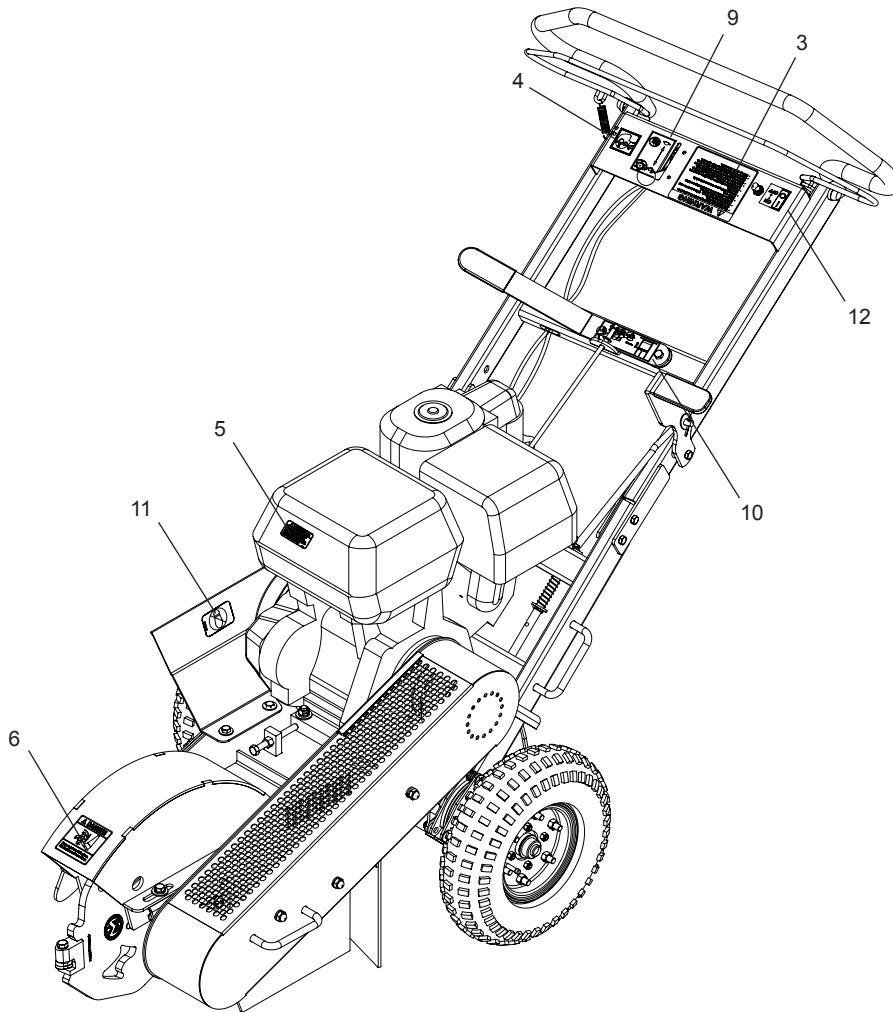

Decal 3

Important information

Read and make sure you understand the Operator's Manual before use or maintenance.

To obtain a replacement manual, contact your dealer.

Observe all safety instructions; otherwise you may injure yourself or others.

Make sure the machine is in serviceable condition prior to use.

Stop the engine and wait until all machine movement comes to a standstill before service, adjustment or cleaning.

Do not run the engine in poorly ventilated spaces.

Make sure nobody is in the vicinity of the machine before starting and during use.

Avoid slopes that are too steep to use the machine safely.

Clear any debris prior to use.

Decal 4

Wear goggles or safety glasses and ear protection when using the unit.

Decal 5

Warning

Engine exhaust, some of its constituents and certain vehicle components contain or emit chemicals considered by the State of California to cause cancer, birth defects or other reproductive harm. The engine emits carbon monoxide, which is a colorless, poisonous gas. **DO NOT** use the machine in enclosed spaces.

Decal 6

There is DANGER to your feet from the cutting blades.

Decal 9

Rabbit = Fast engage clutch.

Turtle = Slow disengage clutch.

Decal 10

Handle adjustment.

Decal 11

No step.

Decal 12

O = off, I = on

SAFETY

General use

This manual is a valuable document. Read the contents carefully before using or servicing the machine. The following of instructions (use, service, maintenance, etc.) by all who operate this machine is important for the safety of the operator and others.

It can also considerably increase the life span of the machine and increase its resale value.

Read the manual carefully and make sure you understand it before using the machine or performing any maintenance. If the user cannot read this manual, it is the responsibility of the machine owner to explain the contents to the user.

If after reading the operator's manual you are still unsure about the safety risks associated with use of the machine, you should not use the machine. Please contact your dealer for more information.

These safety instructions only address the basics for safe use. It would be impossible in the safety instructions to describe all possible risk situations that could arise when using the machine. You can, however, prevent accidents by always using common sense.

To obtain extra copies of the operator's manual, please contact your dealer.

IMPORTANT INFORMATION

Do not use the machine until you have read the operator's manual carefully and understand the instructions given. All maintenance work or adjustments not described in this manual must be performed by an authorized Husqvarna service workshop.



WARNING!

Under no circumstances may the original design of the machine be modified without written approval from the manufacturer. Such modifications not only affect the performance and durability of the machine but may even pose a safety risk for users and those in the vicinity. Unauthorized modifications to the design of the machine may absolve the manufacturer from liability for any resulting personal injury or property damage. Modifying the machine without written approval from the manufacturer may void the guarantee.

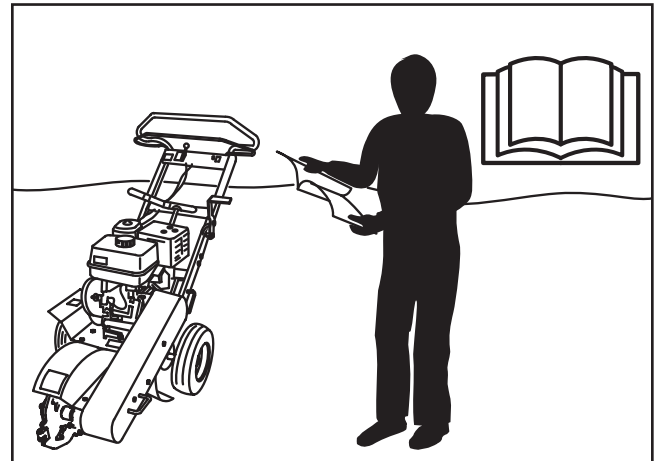

8011-208c

Read this manual carefully before starting the machine.



WARNING!

The stump grinder can be dangerous if used improperly or without due care. This can lead to serious accidents or, in the worst cases, even fatal accidents. It is very important to read this operator's manual and understand the instructions before attempting to use the machine.

SAFETY

- Follow all safety instructions. Failure to do so may result in injury to yourself or others.
- Accident prevention regulations, other general safety regulations, occupational safety rules and traffic regulations must be followed without fail.
- All users shall be trained in use of the machine. The owner is responsible for training users.
- Engage an authorized Husqvarna workshop for all service and repairs not described in this manual.
- Husqvarna original spare parts are designed and specified to maintain high quality and correct fit for optimal durability and life-span. From a safety point of view, use only Husqvarna original spare parts.
- Learn how to use the machine and its controls safely and learn to recognize the safety decals.
- Only use the machine for removing tree stumps. It is not intended for any other use.
- Check that the machine is in serviceable condition prior to use; see Maintenance.
- Only use the machine in daylight or in other well-lit conditions. Keep the machine a safe distance from holes or other irregularities in the ground. Pay attention to other possible risks.
- Only allow the machine to be used by adults who are familiar with its use.
- Never allow persons not trained in the use of the machine to service it.
- Never allow persons or children not trained in the use of the machine to operate it. Local laws may regulate the age of the user.
- People and animals can cause distractions and cause loss of control of the machine. Always concentrate and focus on the task.
- Never leave the machine unsupervised with the engine running.
- Make sure that other people are nearby when you are using the machine so that you can call for help should an emergency arise.
- The machine is tested and approved only with the equipment originally provided or recommended by the manufacturer.



WARNING!

The engine can become very hot. To avoid being burned, you must turn off the engine and wait until all parts have cooled before touching the engine.



WARNING!

Overexposure to vibration may lead to circulatory or nerve damage, particularly in people who have impaired circulation.

Contact your doctor if you experience symptoms that could have been caused by overexposure to vibration. Examples of common symptoms include numbness, pain, muscle weakness, change of skin color or an uncomfortable feeling of tingling. These symptoms appear most frequently in the fingers, hands or wrists.

IMPORTANT INFORMATION

Never use a stump grinder that is damaged or incorrectly adjusted. Never use the stump grinder if any component is missing or if it is not properly assembled. Check that the cutting tools stop rotating when you reduce the throttle. If you find yourself in a situation where you are not sure what to do, always seek expert assistance. DO NOT try to resolve problems you are not qualified for.

SAFETY

Preparations

- Make sure that you always have first aid equipment at hand when using the machine.
- Make sure nobody else is in the vicinity of the machine when you start the engine, engage the drive or run the machine.
- Make sure animals and people maintain a safe distance from the machine.
- Check that the dead man's grip and all guards are fitted and functioning. DO NOT use the machine if it is not working properly.
- Make sure no clothing, long hair or jewelry can catch in moving machine parts.
- Check that all safety decals are in place. See the chapter "Location of decals".
- Use face protection, protective gloves with good grip and protective clothing which you can move unrestricted. Also use leg protection to protect from sparks and the cutting tools.
- Never use the machine when barefoot. Always wear anti-slip protective shoes or protective boots preferably with steel toes.
- Use a helmet with a full face visor or a mesh visor and protective glasses. Wear approved ear-protection when running the machine. Ask your dealer about approved protective glasses, ear protection and recommended helmets.

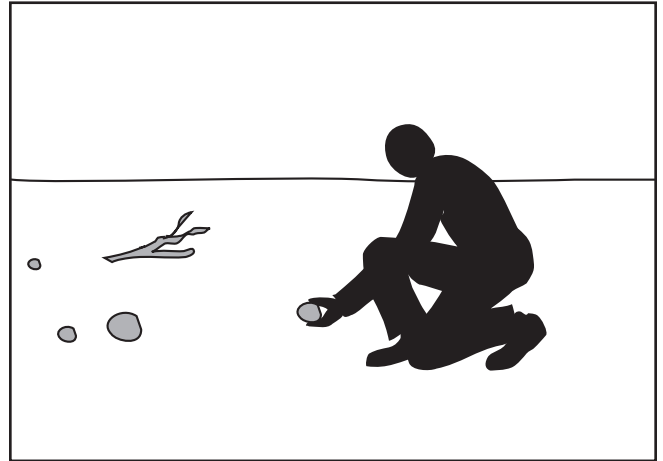

8011-198

Clear the work area before beginning work.

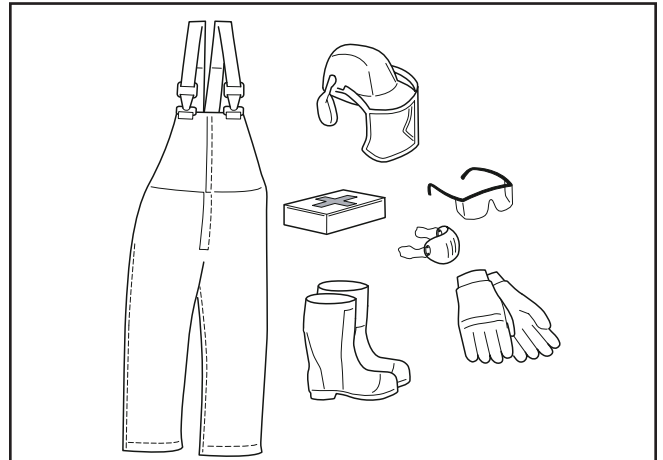

8011-189

Use appropriate equipment.



WARNING!

Always use approved protective clothing and approved protective equipment when using the machine. Protective clothing and protective equipment cannot eliminate the risk of accidents, but wearing proper clothing and the correct equipment will reduce the degree of injury should an accident occur. Ask your dealer about approved protective clothing and approved protective equipment recommended by Husqvarna.

SAFETY

Operating

- Do not use the machine on grades of more than 10°.
- Do not use the machine if you are tired, if you have consumed alcohol, or if you are taking other drugs or medication that can affect your vision, judgment or coordination.
- Never use the machine indoors or in spaces lacking proper ventilation.
- Make sure you have a proper foothold when using the machine, particularly when backing. Walk, don't run. Never work on wet grass. Poor traction may cause you to slip.
- Keep your hands and feet away from moving parts.
- Keep your hands and feet away from the work tools.
- Do not use your feet or other parts of your body to gain greater bearing pressure against the stump.
- Smoking, open flames or sparks in the vicinity of the machine are strictly forbidden. Gasoline is extremely flammable and carelessness in handling can result in personal injury or fire.
- Never use a machine with a defective muffler.
- In very warm and dry climates, stump grinder operation poses a risk of forest fires.
- Stop and inspect the equipment if you run over or into anything. If necessary, make repairs before beginning again.
- Whatever happens, you should always park the machine on even ground, disengage the drive, activate the parking, turn off the engine and wait until all moving parts have stopped before leaving the operating position behind the machine.



WARNING!

Engine exhaust, some of its constituents and certain vehicle components contain or emit chemicals considered to cause cancer, birth defects or other reproductive harm. The engine emits carbon monoxide, which is a colorless, poisonous gas. Do not use the machine in enclosed spaces.

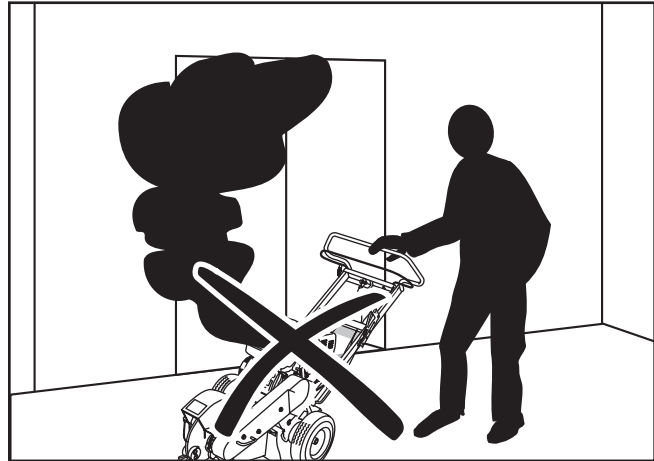

8011-209b

The engine exhaust is poisonous. Never run the engine indoors.



8011-091

Make sure you keep your hands and feet away from moving parts.

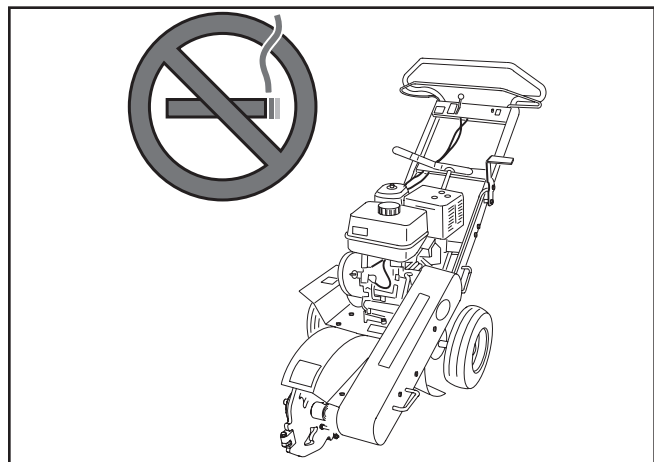

8011-291c

*Smoking near the machine is **strictly** prohibited.*

SAFETY

Movement/Transport

- To turn and steer the machine, press down on the handle and turn on the back wheels.
- Turn off the engine and allow it to cool at least two minutes before transport.
- Fold the handle down if the machine is equipped with a collapsible handle.
- Use safe lifting and moving techniques when loading/unloading the machine.
- It is recommended that two people lift the machine.
- Activate the parking brake during transport.
- Fasten the machine properly in place with approved fasteners, such as tension belts, chains or straps. Always check for compliance with applicable traffic regulations before transporting the machine.

Storage

- Allow the engine to cool before storing the machine. Never store the machine near a open flame.
- Store the machine with the fuel valve closed.
- Store the machine and fuel in such a way that there is no risk that leaking fuel or fumes can come in contact with flames or sparks from electrical machines, electric engines, relays, switches, boilers or similar.
- Store the machine in a locked space away from children and adults untrained in its use.

Children

Serious accidents can occur if you fail to be on guard for children in the vicinity of the machine. Never assume that children will stay where you last saw them.

- Keep children away from the machine.
- Keep children away from the work area and under close supervision by another adult.
- Shut off the machine if children enter the work area.
- Never allow children to operate the machine.
- Be particularly careful near corners, bushes, trees or other objects that obstruct view.

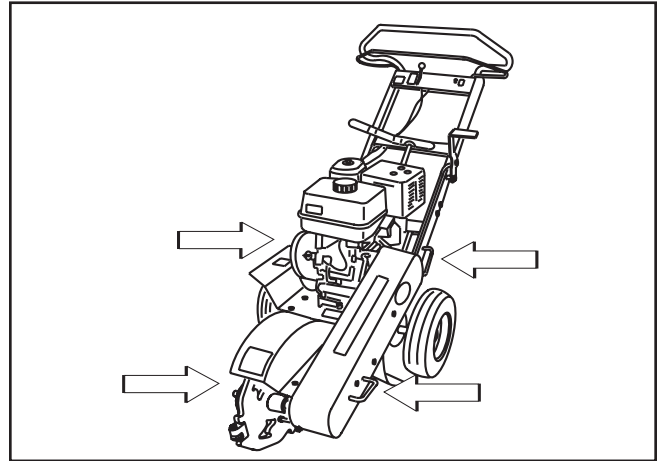

8011-278b

Lift the machine with the side handles.

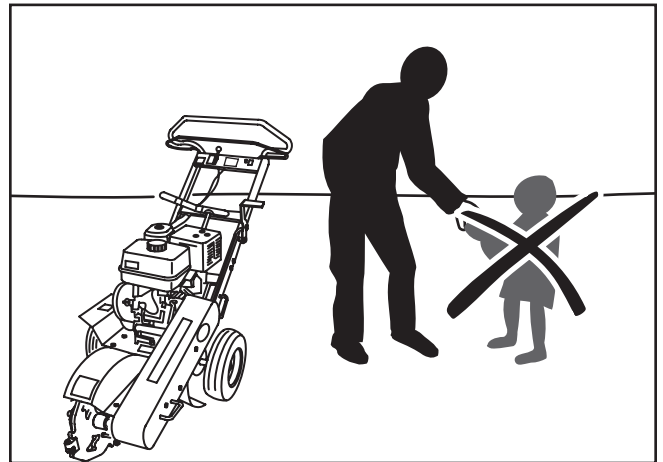

8011-207c

Keep children away from the machine.

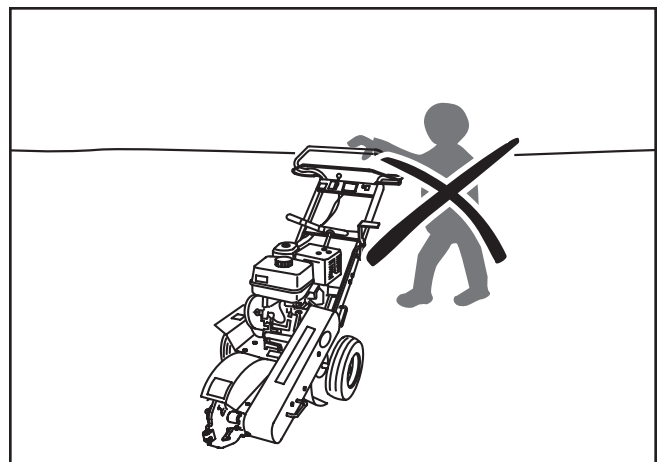

8011-206b

Never allow children to operate the machine.

SAFETY



WARNING!

Gasoline and gasoline fumes are poisonous and extremely flammable. Be especially careful when handling gasoline, as carelessness can result in personal injury or fire.

Fuel System

- Store fuel only in containers approved for that purpose.
- Never remove the fuel cap and fill the fuel tank when the engine is running.
- Always stop the engine when refueling.
- Do not smoke when filling the gasoline tank and do not pour gasoline in the vicinity of sparks or open flame.
- Never fill the fuel tank indoors.
- Before starting the machine after refueling, it should be moved at least 10 feet (3 M) from the location where it was filled.
- Turn off the fuel supply for storage or transport.
- If leaks arise in the fuel system, the engine must not be started until the problem has been resolved.
- Check the fuel level before each use and leave space for the fuel to expand. Heat from the engine and sun can cause the fuel to expand and overflow.
- Avoid overfilling. If you spill gasoline on the machine, wipe up the spill and wait until it has evaporated before starting the engine. Change garments if gasoline is spilled on clothing.

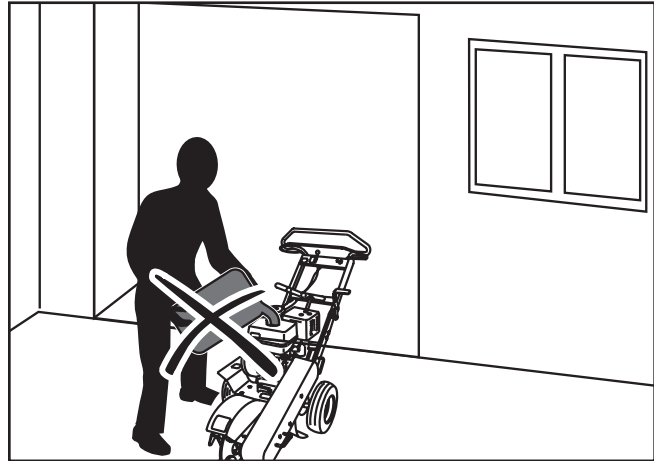

8011-205b

Never fill the fuel tank indoors.

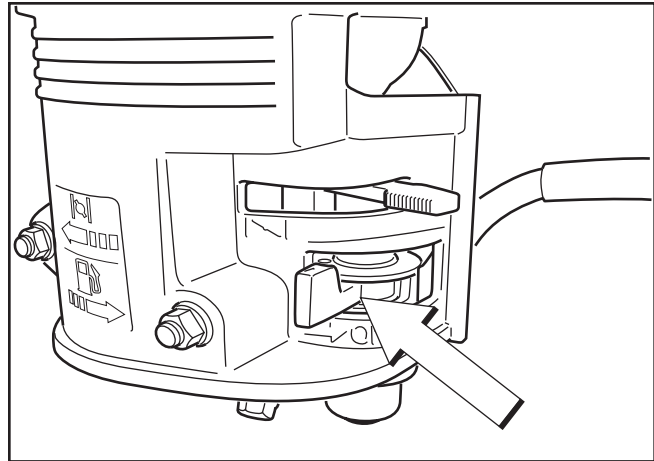

8061-024

Close the fuel valve.

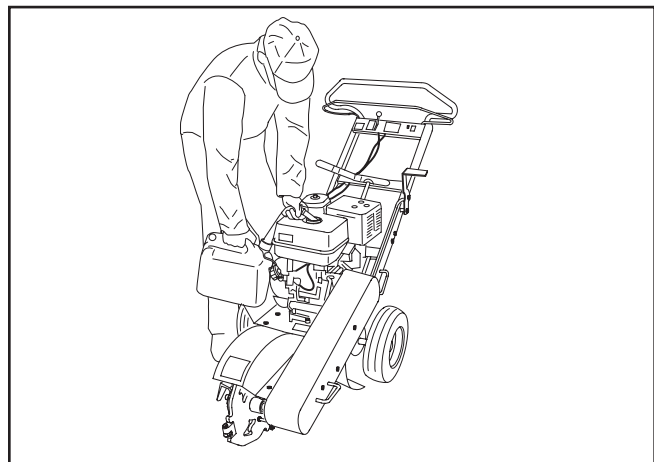

8011-222b

Fueling always poses an element of risk

SAFETY

Maintenance

- Never make adjustments with the engine running.
- Disengage the drive units, shut off the engine and wait until all moving parts come to a complete stop before making adjustments, performing maintenance or cleaning the machine.
- Disconnect the spark plug cable before beginning repair work.
- Keep all components in serviceable condition and make sure all nuts, bolts and other hardware are tight. Replace worn or damaged decals.
- Be careful when checking work tools. Use gloves when performing maintenance work.
- Never allow persons not trained in the use of the machine to perform service on it.
- Always park the machine on even ground before performing maintenance or making adjustments.
- Do not disassemble the engine. This can invalidate the engine warranty. Contact the dealer for questions regarding service or guarantee matters. Follow all maintenance instructions.
- Do not change the setting of governors and avoid running the engine with overly high RPM. If the engine is run too fast, damage to the machine components can occur.
- Do not modify safety equipment. Check regularly to be sure it works properly. The machine must not be run with defective or disassembled safety equipment.
- The muffler is designed to maintain sound levels at an approved level and keep direct exhaust away from the user. Exhaust gases from the engine are extremely hot and may contain sparks that can cause fires or burn the user.
- Never use a machine with a defective muffler.
- Reduce the risk of fire by removing grass, leaves and other debris that may have caught in the machine.

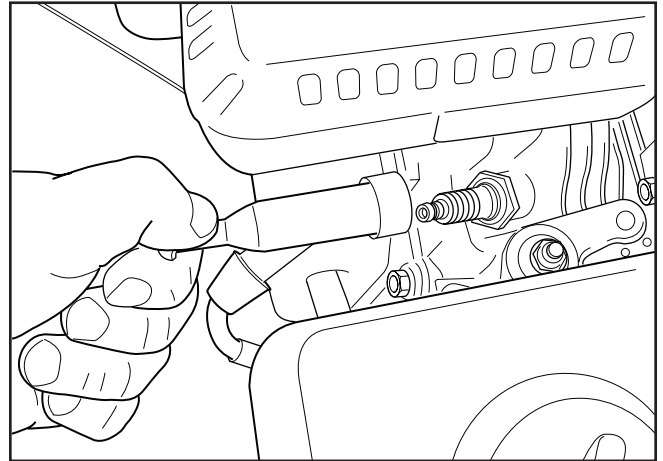

8011-027

Remove the spark plug cable.



WARNING!

Wait until all moving parts are completely still before performing maintenance on the machine. Turn off the engine and remove the spark plug cable.

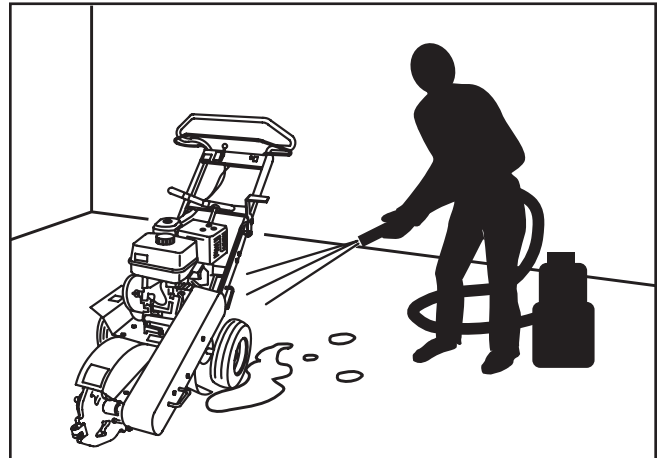

8011-210c

Keep the machine clean.

PROTECTION EQUIPMENT

Personal Protection Equipment

Consult your Husqvarna dealer when selecting protective equipment. Dealers have a broad assortment of equipment for professionals (such as forestry workers) and knowledge about occupational environment requirements and protective levels.

Before using the stump grinder, you may need to cut back the object with a power saw. It is therefore practical to use personal protective equipment that fulfils requirements for working with both stump grinders and power saws.

The main difference is that you should wear protective glasses when operating the stump grinder while the wire mesh visor is sufficient when using a power saw. Thus when using the stump grinder, it is recommended to use both a wire mesh visor to protect your face and protective glasses. A Plexiglas face guard is an alternative, but has been found to scratch easily and is susceptible to soiling and fogging.

You require the following personal protective equipment:

1. Protective helmet (hard hat)
2. Ear protection
3. Face guard
4. Protective trousers
5. Protective glasses
6. Breathing protection (dusty work environment)
7. Protective gloves
8. First aid kit
9. Protective boots or steel-toed shoes

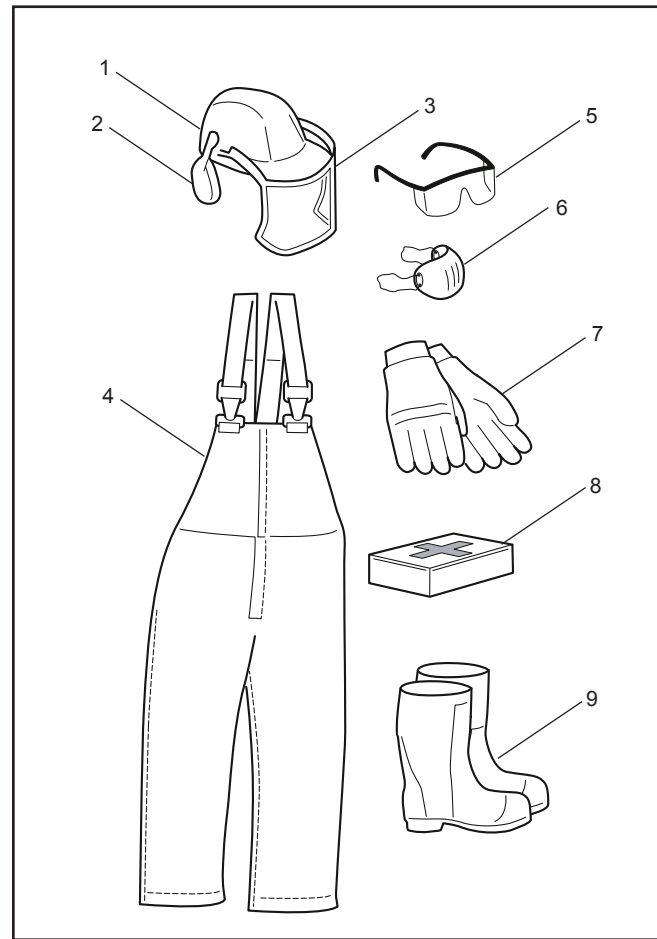

Personal protection equipment

8011-189

SET-UP

1. Remove crate top and sides.
2. Remove upper handle bar assembly and lay aside.
3. Open bag containing loose hardware.
4. Using four (4) screws, flat washers and nuts attach the upper handle bar assembly to lower handle bar assembly.

NOTE: Handle fit is tight. When aligning holes use a tapered type pilot to help align holes (i.e. punch or phillips style screw driver).

5. Attach the position adjusting rod to bracket on the upper handle bar assembly with the washers and cotter pins placed above the rod bracket. Attach the lower adjustment bar to the unit and secure with cotter pin.

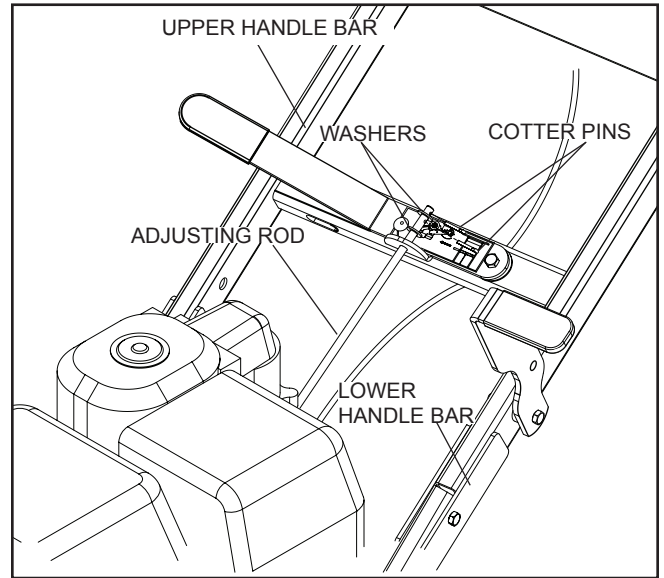

6. Assemble the compression spring, two (2) flat washers and yoke to brake rod assembly.
7. Screw yoke onto the rod assembly until rod is even or through threaded portion of yoke about $\frac{1}{4}$ " (6.35 mm).

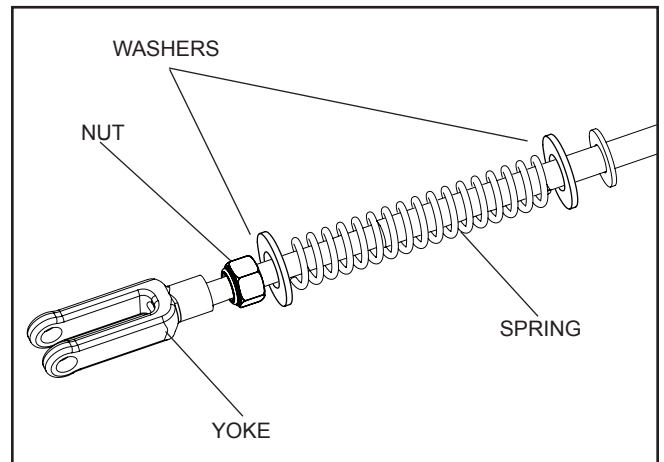

8. Attach brake rod assembly to brake handle on the upper handle bar assembly.

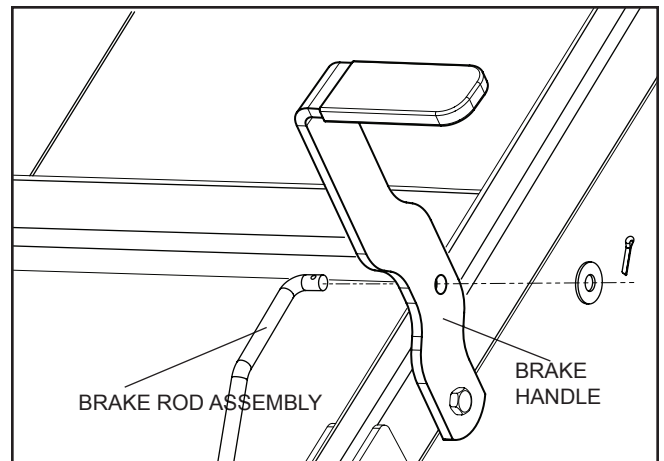

SET-UP

7. Set the brake rod assembly into the brake bracket. The brake rod assembly needs to be adjusted before connecting the yoke to the brake. Turning the yoke clockwise shortens the rod, tightening the grip on the brake disc by the brake pads. Counterclockwise loosens the clamping force.
 8. After adjustment, attach the yoke to the brake's top mounting hole using the clevis pin and cotter pin.
 9. Turn the adjustment nut against the spring and washer until the spring set snugly against the brake bracket and has a small amount of tension. With proper brake adjustment, the wheel will slide, but not turn, when the handle is over center. To engage brake, pull back on the handle until brake rod assembly goes "over center" and locks the brake ON. Test for proper tension and grip.
-
10. Remove air cleaner and double wire clamp from engine.

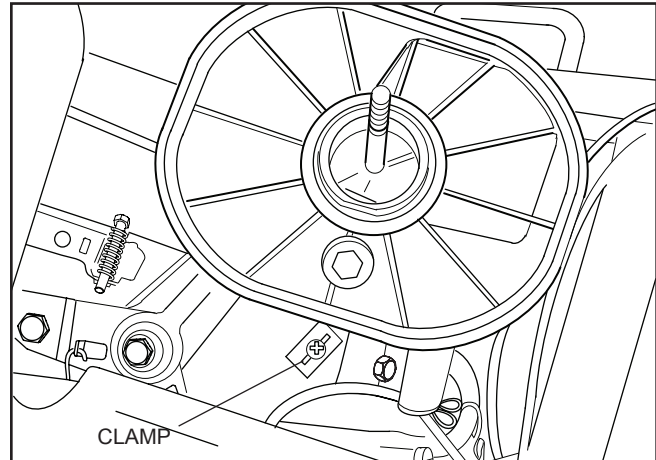
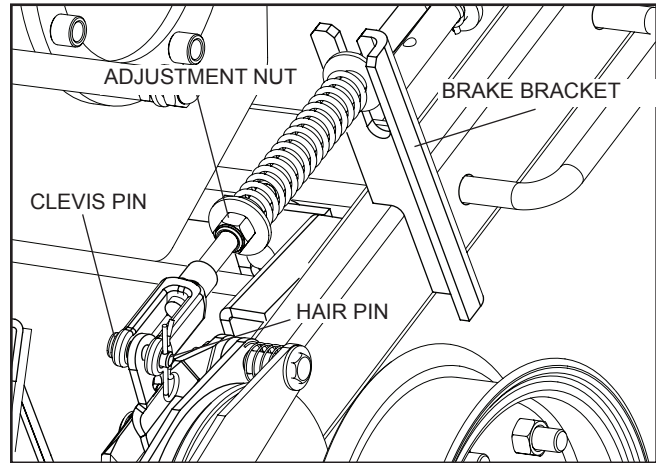

11. Route the wire harness from engine and the throttle cable through guide and handle crossmember.
12. Connect upper and lower wire harness together, yellow to yellow—black to black.

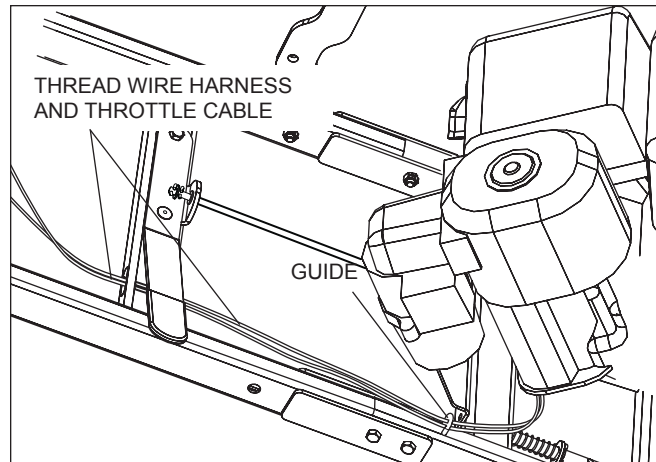

SET-UP

13. Push throttle control lever on console forward to full extent. Pull throttle control lever on engine back as far as possible. Insert "L" end of throttle cable into the outside hole of the engine throttle control lever.
14. Attach the throttle cable to the engine using the double wire clamp removed previously.

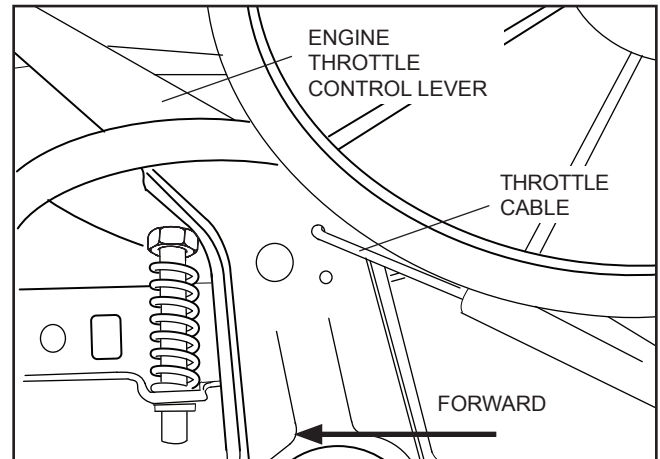

15. Test throttle control by pulling back throttle handle on console. Throttle arm on engine should be pushed completely forward. Cable should not slip in clamp when doing this test.
16. Test proper wire length by pulling on the handle adjustment lever and raising and lowering the handle to maximum position without any pull on harness.
17. Reattach air cleaner to engine.
18. Remove unit from pallet.

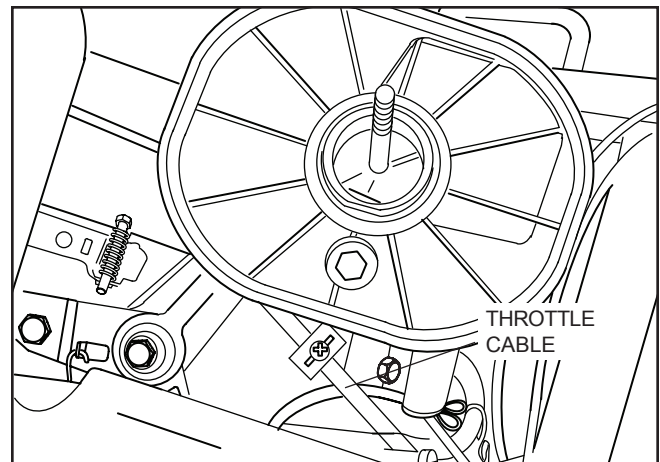

CONTROLS

Main Components and Controls

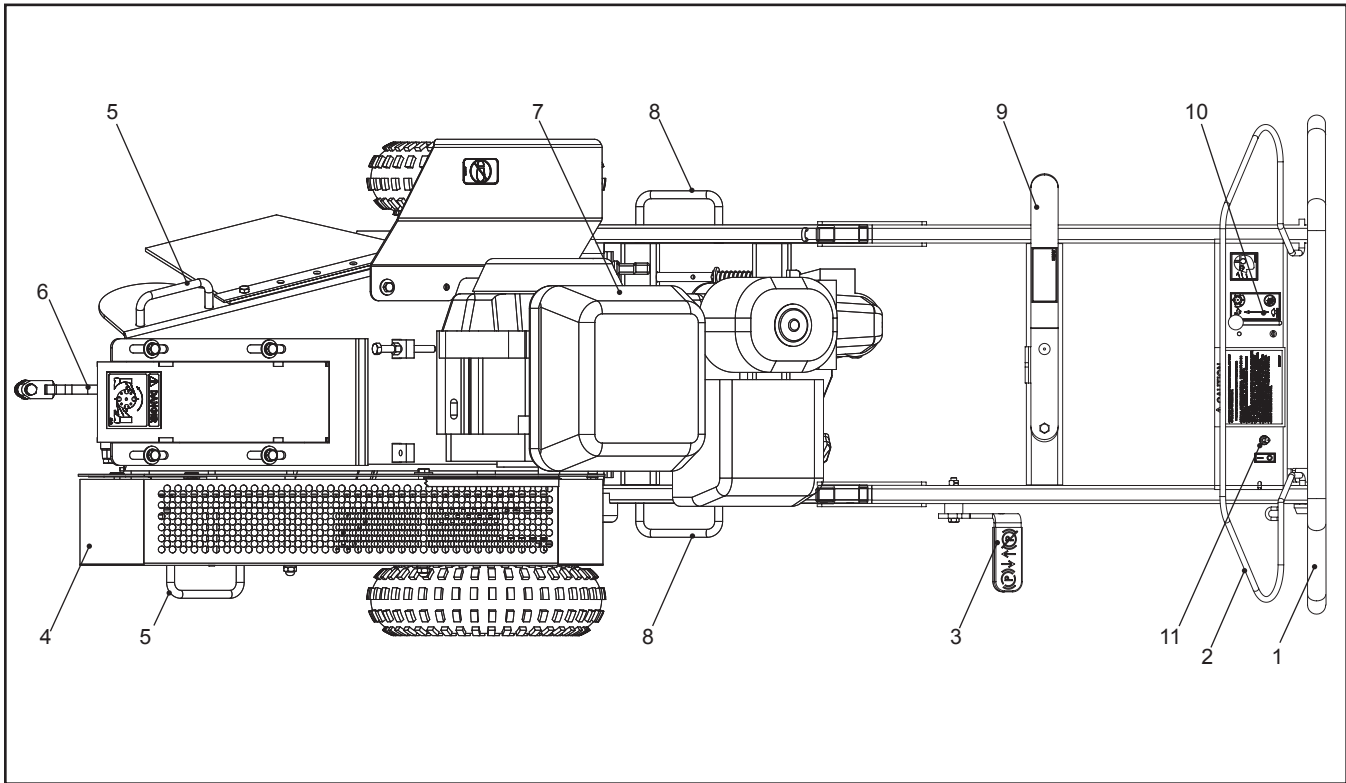

8064-005

- | | |
|-------------------------------|--------------------------|
| 1. Handle | 7. Engine |
| 2. Operator Presence Grip Bar | 8. Rear Lifting Handles |
| 3. Brake Lever | 9. Handle Adjustment Bar |
| 4. Cutter Drive Belt Guard | 10. Throttle |
| 5. Front Lifting Handles | 11. Engine Switch |
| 6. Cutting Wheel | |

CONTROLS

Engine

Exterior engine components and controls.

1. Speed control lever
2. Starter handle
3. Air filter
4. Muffler
5. Fuel Valve
6. Choke control
7. Oil drainage

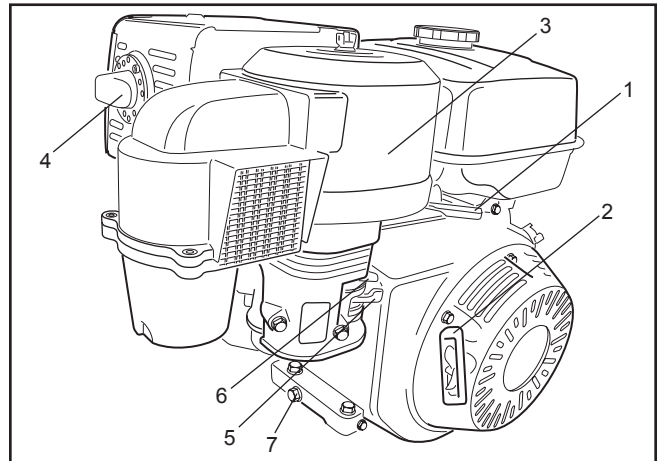

8011-126

8. Oil dipstick
9. Oil level guard
10. Fuel tank
11. Fuel filler cap

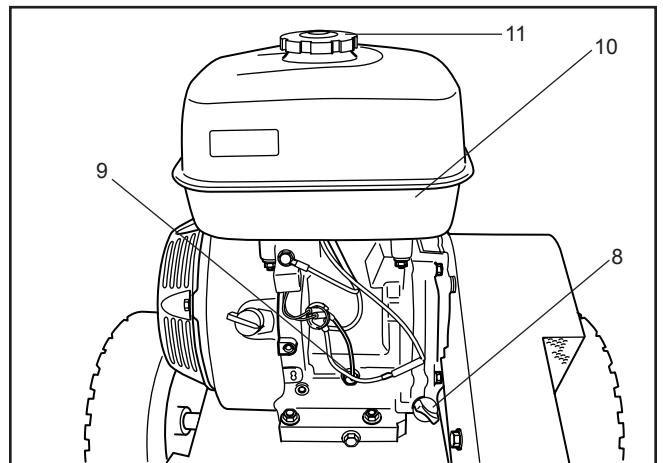

8011-273

Speed Control Lever

The speed control lever on the engine is normally not used. It is connected to the throttle on the handle. If the cable should bind or break, you can reduce the throttle with the lever on the engine as an emergency measure to slow the engine speed to an idle and stop the cutting wheel.

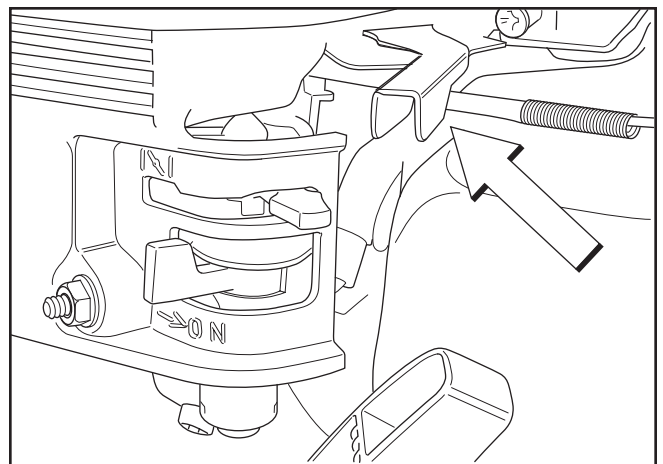

8011-034

CONTROLS

Starter

The magnapull-type starter has spring return. To replace the return spring or starter cord, contact an authorized service workshop.

IMPORTANT INFORMATION

Do not let the recoil cord snap back by itself. This may damage the cord or the recoil starter assembly.

Starter Handle

Misuse of the starter handle can damage the starter. Do not twist the starter cord around your hand.

Pull out the handle slowly until the gears mesh. Do not pull out the starter cord completely and do not let go of the starter handle when extended.

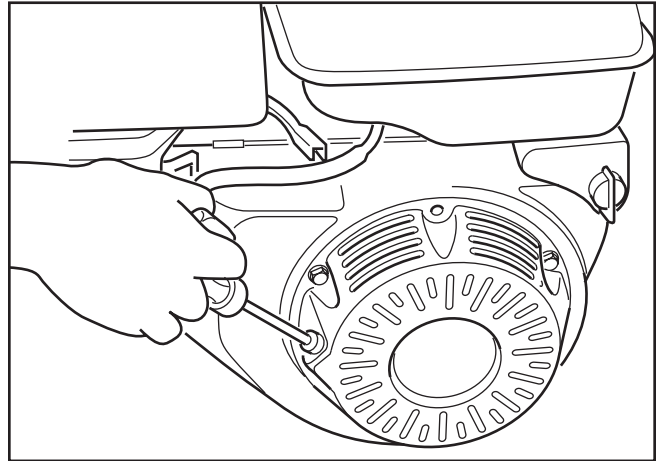

8011-127

Fuel Valve

The fuel valve opens and closes the connection between the tank and the carburetor. The illustration shows the tank valve closed; to open, turn the lever completely to the right. There is no middle position.

Turn off the valve when the machine is not in use to avoid flooding the carburetor. The fuel valve is combined with a sludge reservoir.

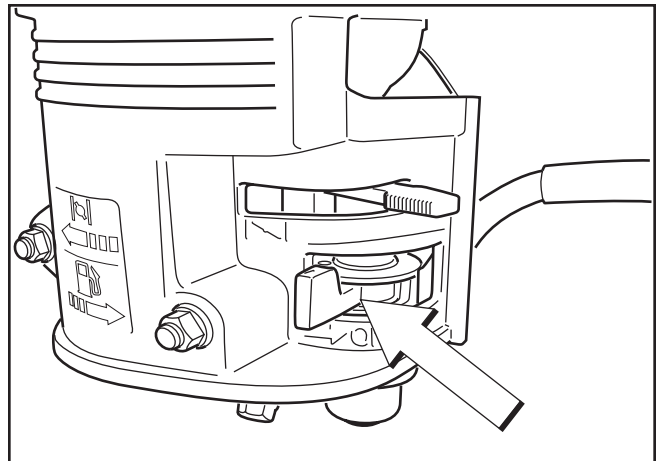

8060-024



WARNING!

Do not run the engine indoors, in enclosed or poorly ventilated spaces. Engine exhaust fumes contain poisonous carbon monoxide.

Choke Control

The choke control opens and closes the choke valve in the carburetor. This is only used to start a cold engine. If the engine is warm, the control should be in the far right position.

If the engine is cold, place the lever completely or partly to the left. Move the lever back to the right once the engine starts. Forgetting the choke is evident if the engine runs roughly and produces black smoke.

This also results in increased fuel consumption.

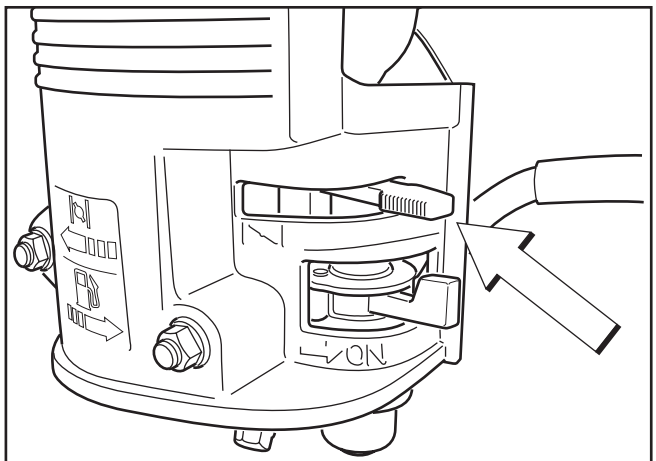

8060-024

CONTROLS

Air Filter

The engine air filter consists of a cyclone filter and a fine filter.

Air is drawn in through the screen (1) on the cyclone filter and coarser pollutants collect in the container (2).

The fine filter, consisting of a foam rubber pre-filter and a paper filter cartridge, is located under the cowling (3). The cowling and the cyclone filter can be removed by removing the wing nut (4).

See Replacing the Air Filter in the Maintenance section for cleaning instructions.

Running the machine with a dirty air filter will cause the engine to run on partial choke and show the same symptoms as a closed choke described above. It can also be difficult to start.

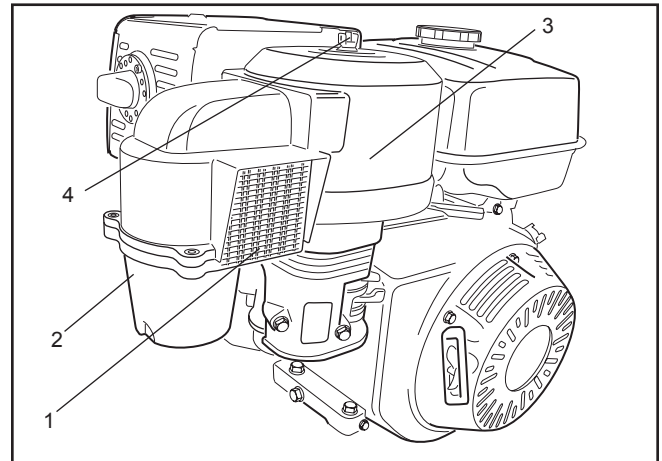

8011-126

Spark Plug

The engine spark plug is hidden under the ignition cable boot. When performing service, it is important that the engine cannot start accidentally. For this reason, always remove the ignition cable boot from the spark plug. To avoid pulling the cable, the cable boot is equipped with a special handle; see the illustration. See *Technical Data* for replacement specifications.

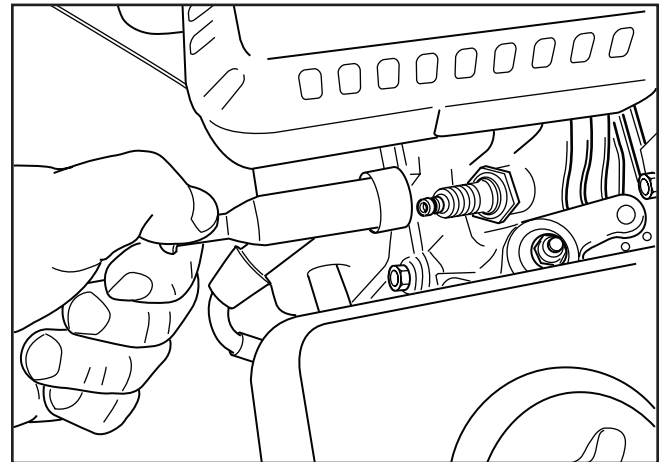

8011-027

Muffler



WARNING!

The engine and the exhaust system, become very hot during operation.

Risk for burns if touched.

Allow engine and exhaust system to cool at least two (2) minutes before refueling

The engine muffler is equipped with a heat protective cowling but still becomes hot when the engine is running. Avoid touching the muffler when it is warm. There is a risk for burns.

CONTROLS

Oil Dipstick

The dipstick for the crankcase oil reservoir is located on the front of the engine. Refill the engine oil in the hole where the dipstick fits.

When checking the oil level, the dipstick should not be screwed in. The machine should be parked on even ground with the engine stopped. Never run the engine without the dipstick in place. The engine has an electronic oil level guard. It stops and cannot be started if the level becomes too low. Yet you should not rely entirely on the level guard; rather you should check the oil using the dipstick.

For normal use, SAE 10W-30 weight engine oil service SF-SG is recommended; see also Lubrication.

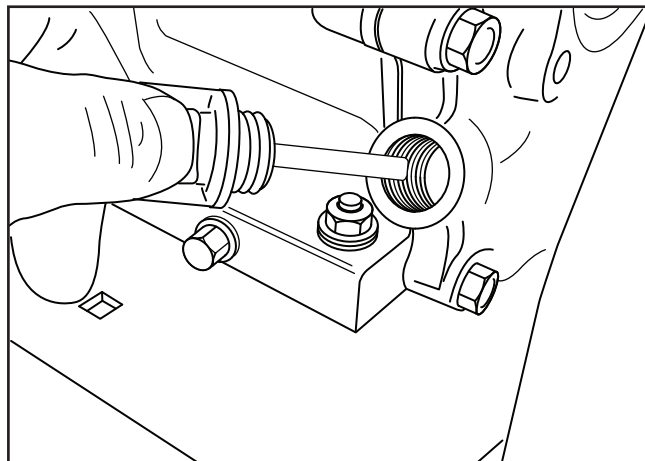

8011-020

Oil Drain

The drainage screw for the crankcase oil reservoir is located on the back of the engine.

IMPORTANT INFORMATION

Used engine oil is a health hazard and legislation prohibits disposal on the ground or in nature; it should always be disposed of at a workshop or appropriate disposal location. Avoid skin contact; wash with soap and water in case of spills.

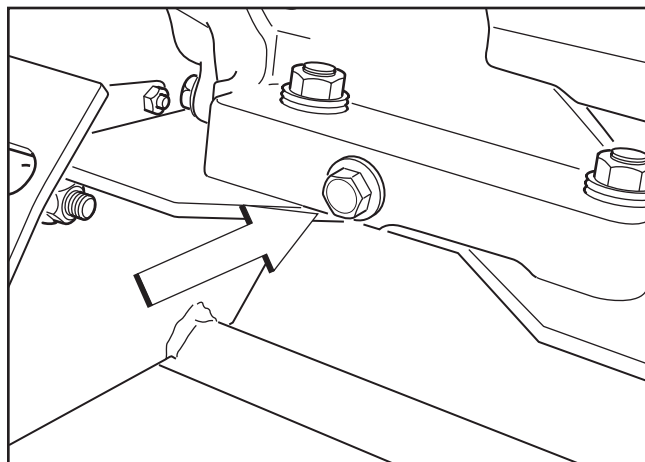

8011-187

CONTROLS

Fuel Tank

Underneath the tank, there is a fuel filter combined with the fuel valve. Tank capacity is 1.72 gallons (6.5 liters)

Fueling

Read the safety instructions before fueling.

Keep the fuel and fuel tank clean. Avoid filling the machine with dirty fuel. Make sure the fuel cap is properly tightened and the gasket is not damaged, particularly before washing the machine.

Use unleaded gasoline with minimum 86 octane rating. Never use gasoline mixed with two-cycle oil. For ethanol and methanol fuel, the following applies:

Maximum allowable ethanol 10% (volume).

Maximum allowable methanol 5% (volume).

Maximum allowable MTBE (Methyl Tertiary Butyl Ether) 15% (volume).

If the engine jerks at normal load it can be damaged. Change the fuel. If this does not help, contact an authorized service workshop.

Do not fill the tank completely; leave space for the fuel to expand as it warms up.

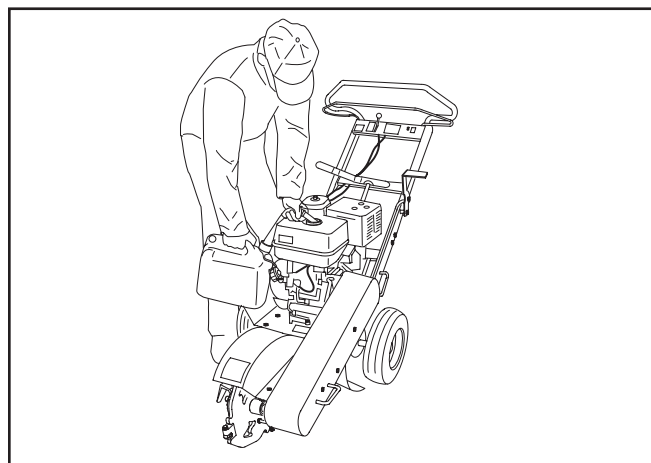

8011-222b

Use clean, fresh fuel



WARNING!

Gasoline is highly flammable. Observe caution and fill the tank outdoors (see the safety instruction).

Centrifugal Clutch

The engine is equipped with a centrifugal clutch that is connected to the crankshaft. When the engine speed increases, the drive for the cutting wheel engages automatically. The centrifugal clutch is maintenance-free; it is not possible for the user to make adjustments.

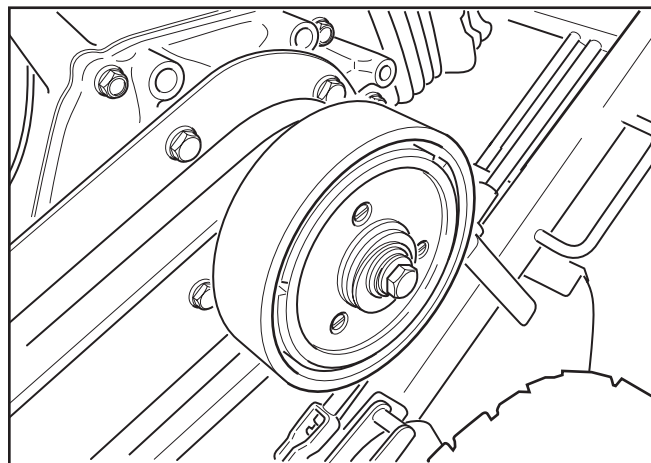

8011-247

CONTROLS

Operator Presence (OP) Grip Bar

The bar must be held against the handle for the engine to run. If the grip is released, the ignition system short-circuits and the engine stops.



WARNING!

Do not over-ride the safety system by binding the bar to the handle.

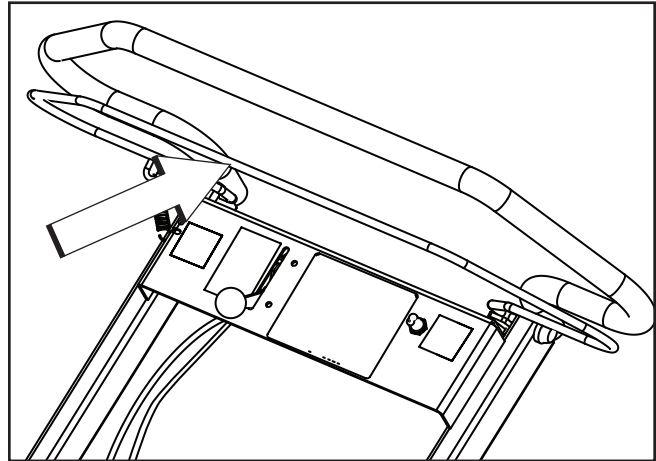

Throttle

The lever controls engine speed.

With the lever down, the engine runs at idle and functions as start position.

When the engine speed increases, the centrifugal clutch drive automatically engages the cutting wheel.

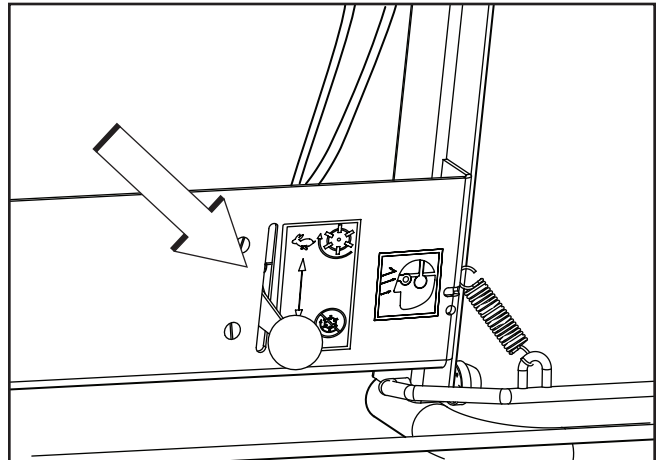

Control Panel On/Off Engine Switch

The ON/OFF engine switch can be used to stop the engine. The illustration shows the toggle switch in the OFF position (short circuited electrical system).

A second switch with the same function is activated by the OP grip bar.

To start the engine, the control panel switch must be set to the ON position and the OP grip bar must be held in.

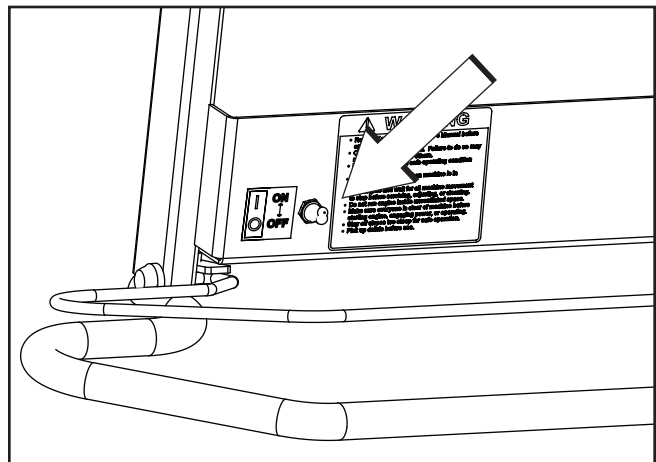

CONTROLS

Brake

The lever activates a disk brake on the left wheel when it is pulled backwards. The brake should always be activated when the grinder is parked, is being transported or when it is in operation



WARNING!

NEVER operate a machine with a defective brake.



WARNING!

To avoid the risk of losing control of the machine, **DO NOT** pull out the adjustment bar when the cutting wheel is rotating.

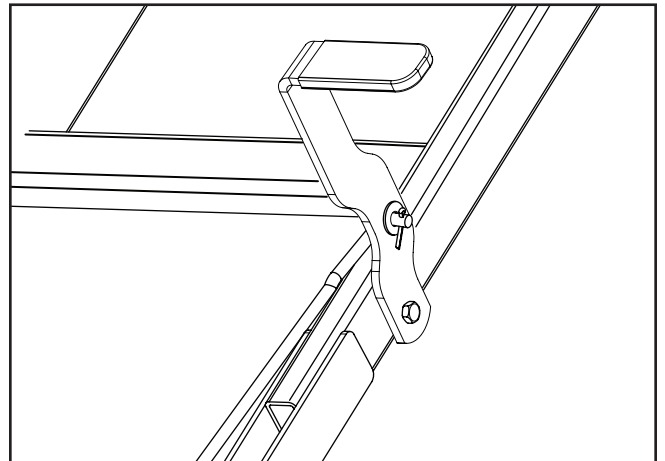

Handle Adjustment Bar

As the tree stump is ground away, the handle position will need to be adjusted. Pull the handle backwards and set the handle at a suitable working height. Engagement rods are spring loaded to insure positive locking when released, but always make sure bolts are locked into place after adjustments are made.

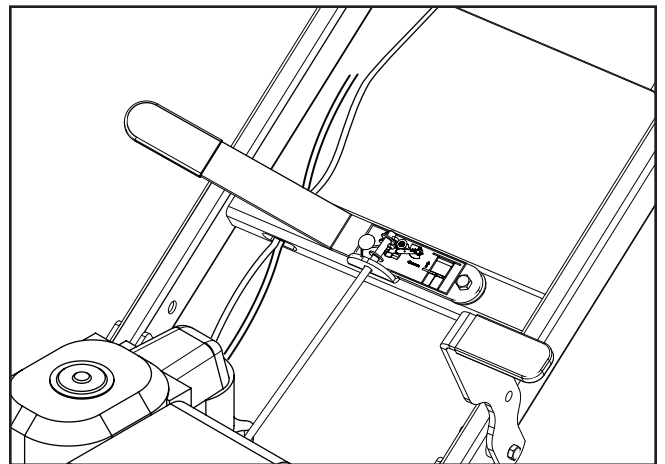

OPERATION

Preparation

- Dig away the earth and remove any stones near the tree stump that may interfere with your work. Check that the ground is free of foreign objects, such as electrical cables, barbed wire, etc.
- Cut or trim the stump as necessary using a power saw.
- Review all of the machine's safety decals.



8011-141

- Use a hard hat, ear and eye protection. A mesh visor alone does not provide sufficient eye protection; supplement with protective glasses.

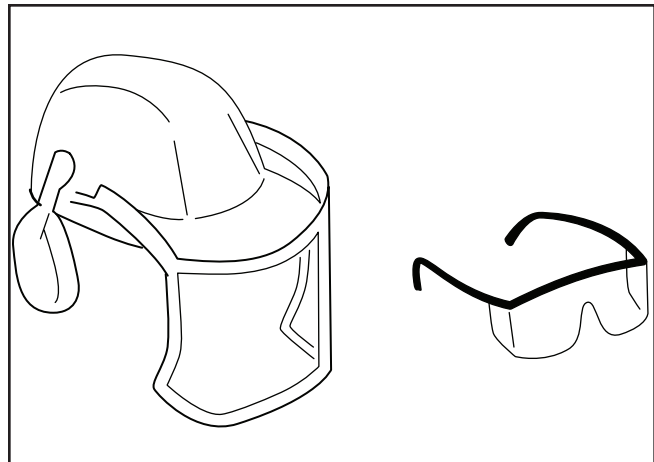

8011-191

- Make sure that you are familiar with safety regulations and shutdown procedures described previously in the operator's manual.
- Make sure that all guards are in place and in good condition.
- Make sure that the blades and cutters are in place and in good condition.
- Make sure that the work area and cutter in particular are free from metallic objects such as wire, nails, etc. that could be thrown out and injure persons in the vicinity and damage the equipment.
- Make sure that everyone, including children and animals, maintains a distance of at least 50 feet (15 M) from the machine. Debris can be thrown out and injure people and animals.

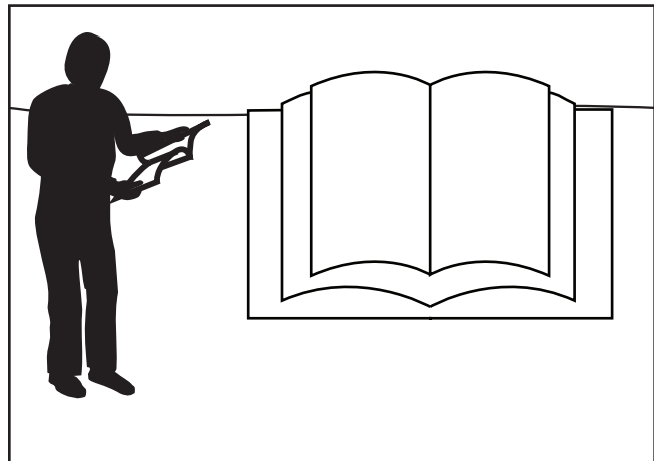

8011-193

OPERATION

Starting The Engine

Check that all daily maintenance as described in the maintenance schedule has been performed. Check that there is sufficient fuel in the tank.

Fuel valve

Open the fuel valve. Push the lever fully to the right.

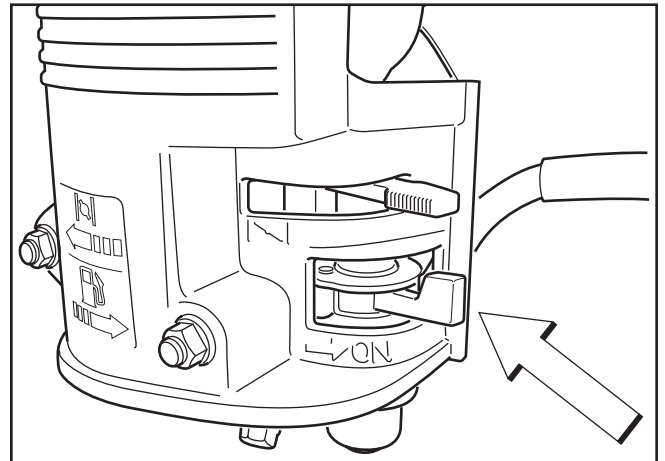

8060-024

Choke control

When starting the engine warm, the lever should be in the right position; see the illustration.

When starting the engine cold or partially warm, place the lever completely or partly to the left. Move the lever back to the right once the engine starts. When the engine is cold, it may be best to move the lever back in several stages. Find the position where the engine runs smoothly.

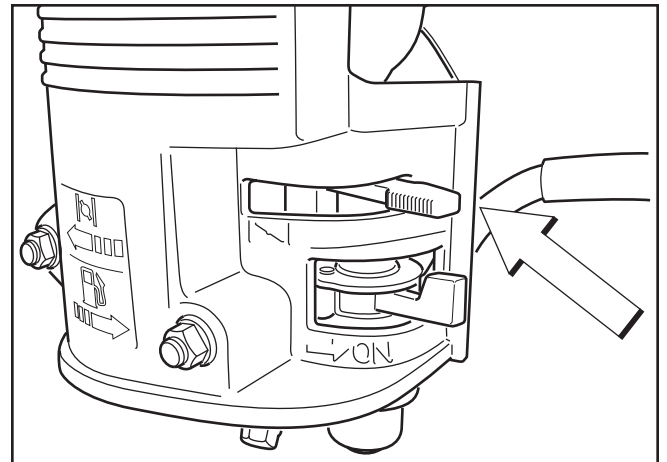

8060-024

Throttle

Set the throttle on the handle to the SLOW (START) / DISENGAGE position.

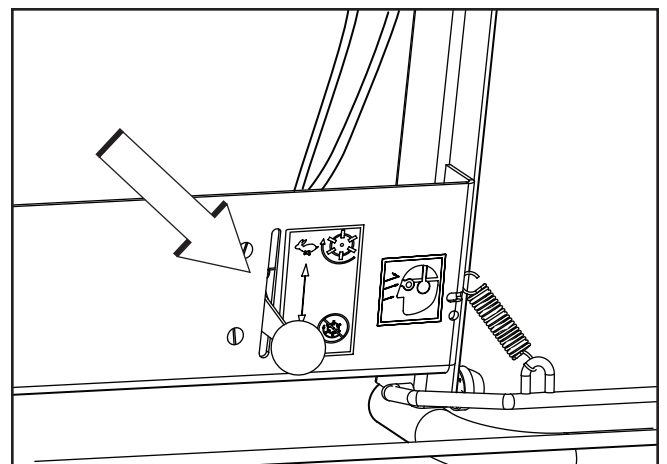

HUSQVARNA-27

OPERATION

Handle Engine Switch

Set the toggle switch to ON.

Engine ON/OFF Switch

The switch on the engine is disconnected. Use the Handle Engine Switch.

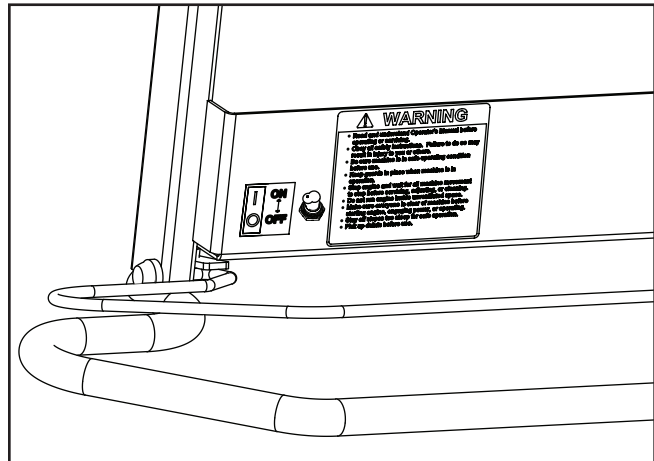

8060-026

OP Grip Bar

Hold in the bar for the OP grip bar against the handle.

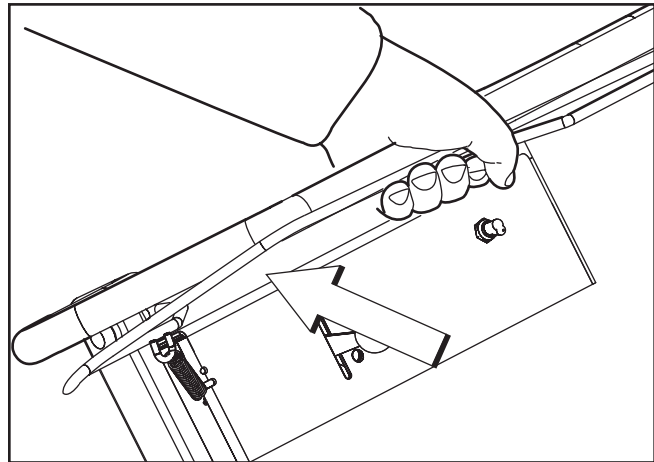

8060-029

Starter Handle

The OP grip bar must be held against the handle when starting the engine.

Misuse of the starter handle can damage the starter. DO NOT twist the starter cord around your hand.

Pull out the handle slowly until the gears mesh. Then give a sharp pull on the starter handle. DO NOT pull out the starter cord completely and DO NOT let go of the starter handle when extended. Return the handle to the recoil position.

Throttle

Keep the throttle at idle. When the throttle is increased, the cutting wheel will begin rotating.

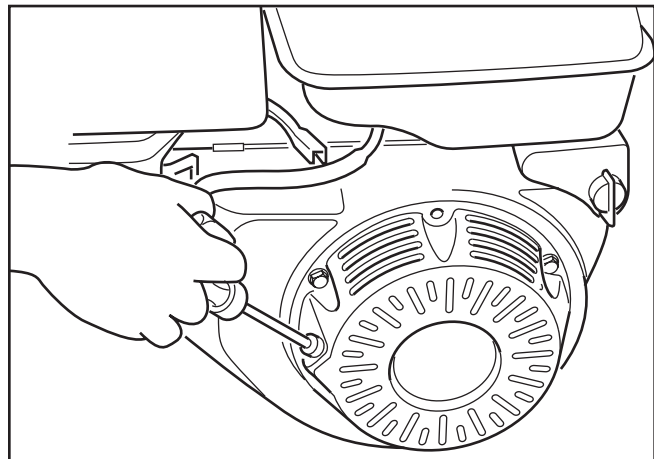

8011-127

OPERATION

Procedure



WARNING!

NEVER allow the blade to touch the ground until it has stopped turning

1. Place the cutting blade near the top front edge of the tree stump.
2. Set the brake to lock position.

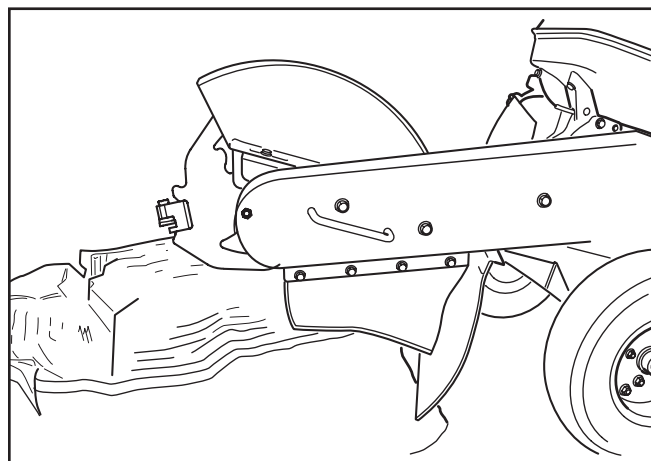

8011-201c

3. Set the throttle to SLOW (START) DISENGAGE.

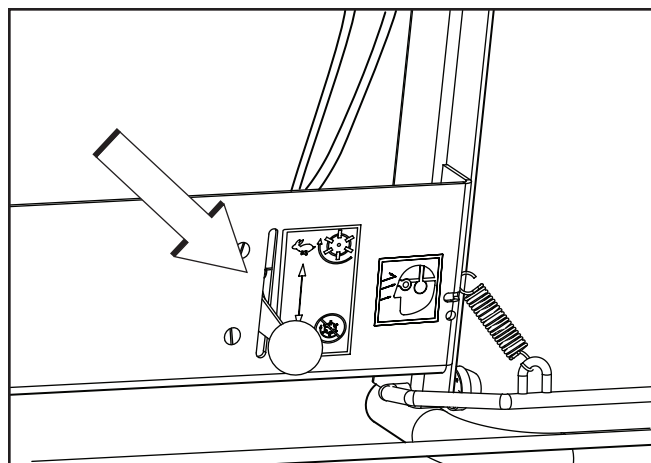

4. Set engine switch on handlebar to ON.

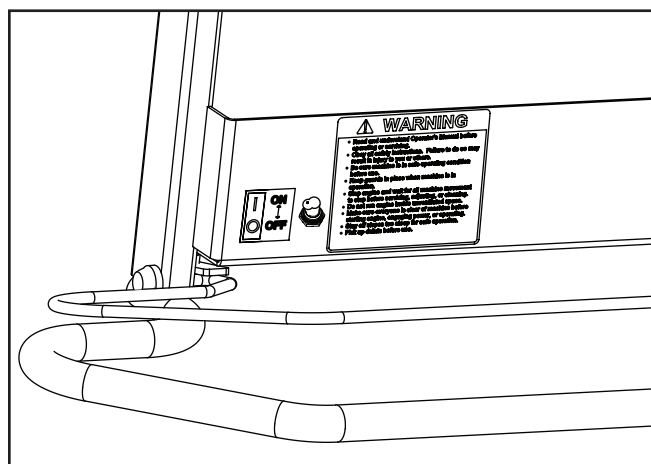

8060-026

OPERATION

5. Tilt the machine on its wheels, lifting the cutting wheel off the ground.
6. Hold in the OP grip bar and start the engine.
7. Allow the engine to warm up for two minutes at idle before grinding.

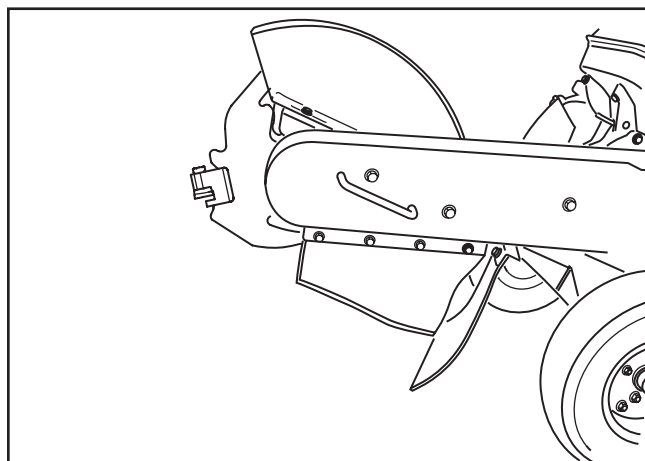

8060-200

8. Set the handle throttle to FAST to engage clutch.

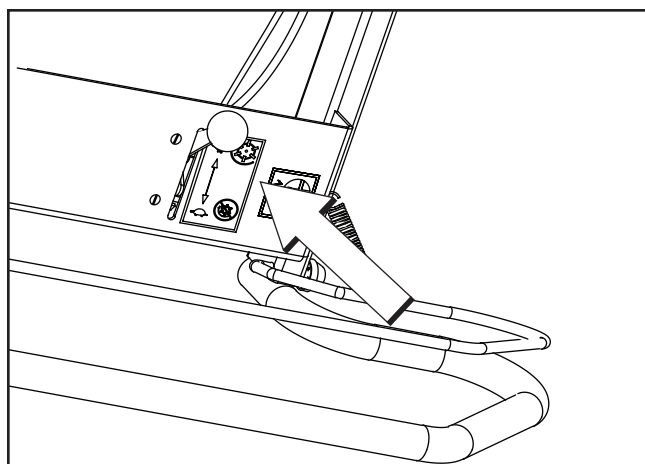

8060-027

9. Place the middle of the cutting wheel approximately 1" (2.5 cm) above and $\frac{3}{4}$ " to 1 $\frac{1}{2}$ " (2-4 cm) into the stump.
10. Place the cutting wheel in the upper front edge of the stump. Swing the cutting wheel from side to side while lowering it about 1" (2.5 cm) after each pass until the front edge of the stump is gone.

IMPORTANT INFORMATION

If the cutting wheel is too low, the machine may start to "climb" over the stump and become unstable.

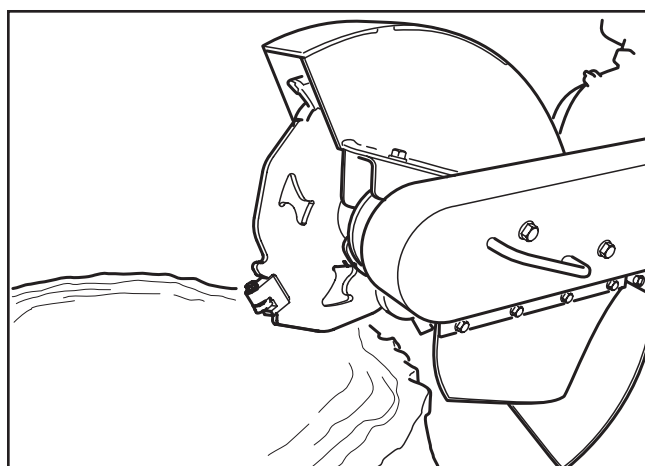

8011-203a

OPERATION

11. Before moving the machine forwards, you should ensure that the cutting wheel is above the ground and located on either side of the stump. Move the machine forward by releasing the brake, pushing it forward, activating the brake again and repeating Steps 9 and 10.
12. Repeat Steps 9 through 11 until the upper portion of the stump has been removed. **DO NOT** cut deeper than ground level at this stage.
13. Set the throttle to SLOW/(START) DISENGAGE and wait until the cutting wheel stops rotating.
14. Release the brake and pull the machine away from the stump.
15. It may be necessary to clear wood chips from the area around the stump.
16. If you want to grind below the ground level, it may become necessary to adjust the handle position to achieve a better hand and arm work position. Pull the handle control lever and adjust the handle to the desired position.
17. Repeat Steps 6 through 10 until you reach the desired depth.
18. Shut off the machine when you are done.

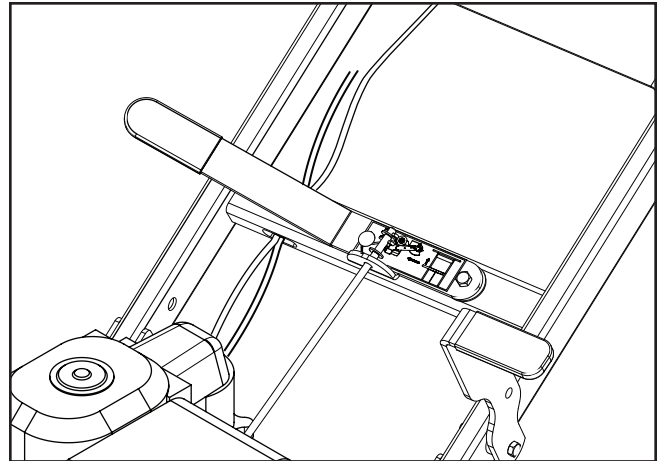
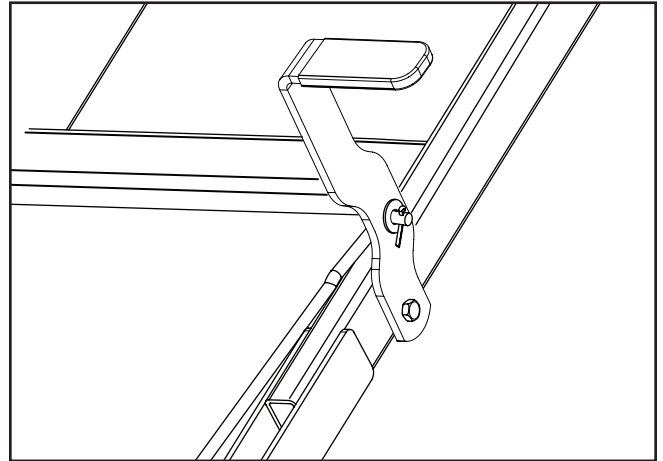

Operating On Hills

Be very careful when operating the stump grinder on hills because the machine can slip or move unexpectedly.

NEVER use the machine on grades of 10° or steeper.

Transport

The Husqvarna stump grinder can be transported in a truck, trailer, van or a large SUV (Sport Utility Vehicle). The stump grinder is equipped with four lifting handles (two on each side) so that two people can lift the machine if necessary.

DO NOT attempt to lift the machine alone. Use safe lifting techniques and **DO NOT** exceed your physical limitations.

Secure the machine with tensioning belts, chains or other approved materials.

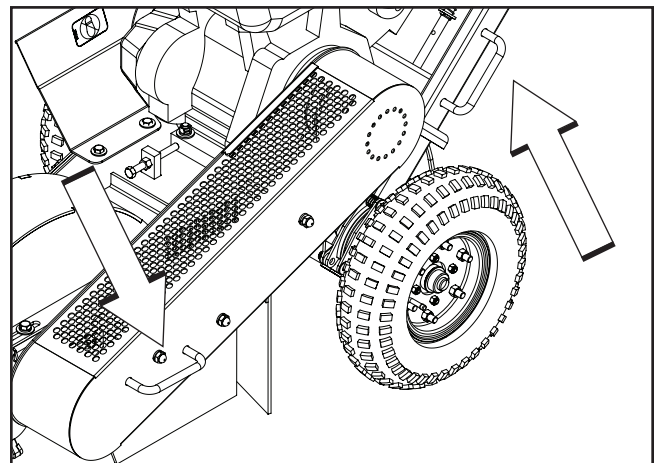

The lifting handles can also be used to secure the machine for transport.

OPERATION

Normal Shutdown

Throttle

Set the throttle to SLOW/DISENGAGE.

If the engine has been running full out, let it run easily for about 30 seconds to 1 minute at low speed.

DO NOT let front of unit touch ground until you are sure cutting wheel has stopped turning.

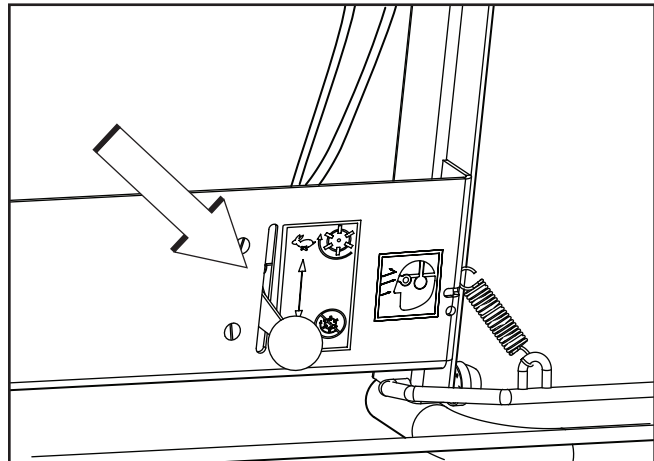

Engine switch

Wait at least 20 seconds, until the blade has stopped.

Set the toggle switch to OFF.

Make sure that the blade is resting against the ground and has stopped completely before doing anything.

Brake

Activate the brake by pulling the lever backwards.

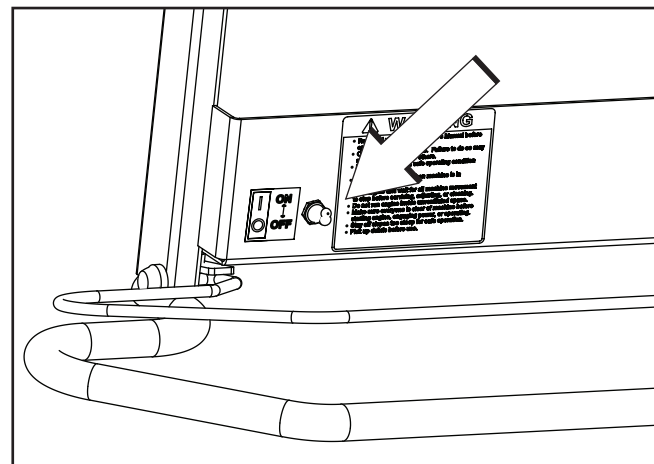

Fuel valve

Close the fuel valve. Turn the lever all the way to the left.

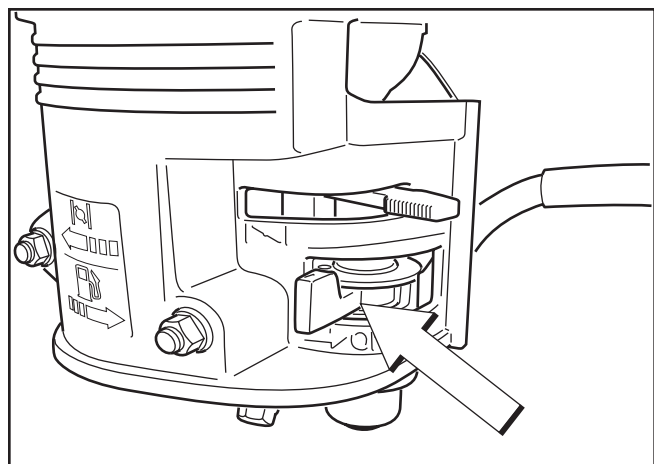

Emergency Shutdown

Release the OP grip bar. Wait until the blade stops.

Make sure that the blade is resting against the ground and has stopped completely before continuing.

8060-024

MAINTENANCE

Maintenance Schedule

The following is a list of maintenance procedures that **MUST** be performed on the machine. For those points not described in this manual, visit an authorized service workshop.



WARNING!

No service operations may be performed on the engine or unit unless:

The engine is stopped.

The ignition cable has been removed from the spark plug.

The machine is securely parked where it will not tip or begin rolling.

MAINTENANCE INTERVALS - MONTHS/HRS

	Daily	-/10	1/25	3/50	6/100	12/300
MAINTENANCE						
Check engine oil level	■					
Change engine oil ¹⁾			■			
Check air filter	■					
Clean air filter ²⁾				■		
Replace air filter cartridge ²⁾						■
Clean sludge reservoir for fuel system					■	
Check and clean spark plug					■	
Replace spark plug						■
Check engine switch function ³⁾	■					
Check idle speed						■
Check and adjust play in valves ⁴⁾						■
Clean fuel tank ⁴⁾						■
Check, replace fuel lines as necessary ^{4, 5)}						■
Check throttle and cable ³⁾	■					
Check blade and cutter ³⁾	■					
Check decals and warning signs ³⁾	■					
Check wear and tension on belts ³⁾	■					
Check chassis, bolts and set screws		■				
Grease the blade bearings (use high temperature grease such as Mobilith SHC 220 or equal) ⁶⁾	■					
Grease the wheels (standard lithium base)				■		
Check tire air pressure (25 psi max)	■					

¹⁾First change after 20 hours. ²⁾In dusty conditions maintenance is required at shorter intervals. ³⁾Before each use.

⁴⁾Performed by authorized service workshop. ⁵⁾Performed every second year. ⁶⁾Grease every 4 hours.

MAINTENANCE

Cyclone Filter

The cyclone filter collects the largest contaminant particles, which collect in the container. When you can see a layer of dirt at the bottom of the container, the cyclone housing (1), air channels and air intake screen (2) must be cleaned.

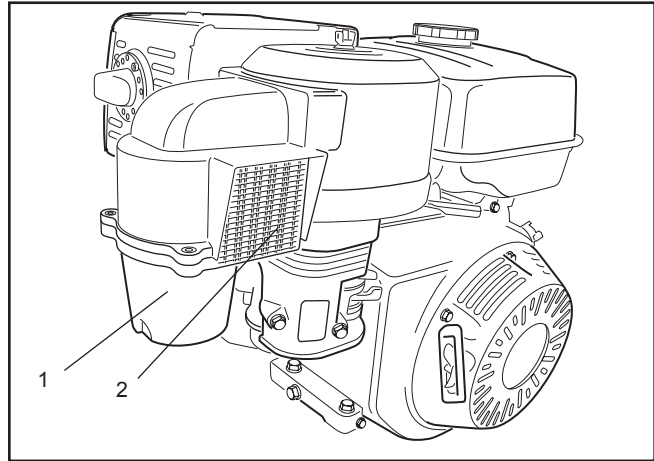

8011-126

Remove the three screws holding the cyclone housing. Remove the housing with the air intake screen and remove the air channels.

The air channels may remain in the upper portion or follow along with the housing when removed.

IMPORTANT INFORMATION

Exercise care when reassembling to avoid damage.

Make sure when mounting that the air intake screen fits exactly in its guide in the upper portion.

Make sure the air channel ends up in the proper position.

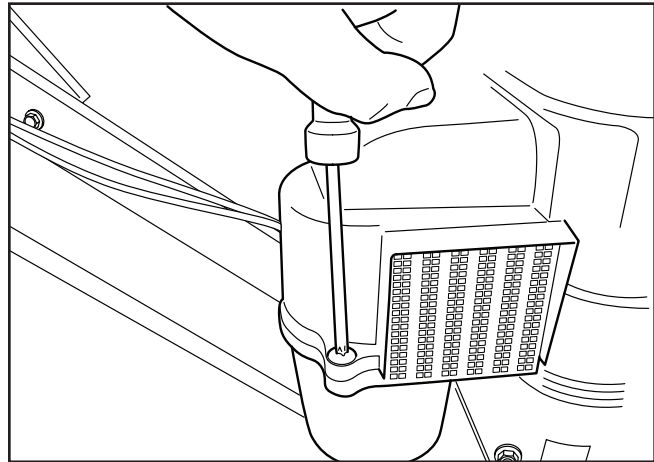

8011-213

Clean the components, using warm water, mild detergent and a sift brush. Dry carefully.

Refit the components. Place the air channels in the cyclone housing. Insert cyclone housing into position and make sure it fits in the upper portion. **DO NOT** use force; rather coax it into place before refitting the screws.

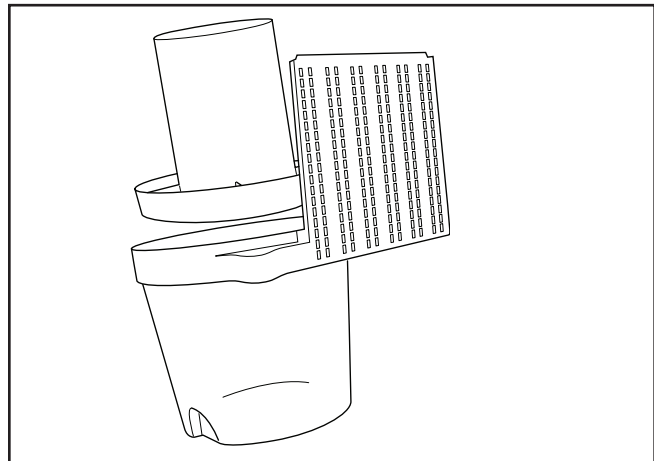

8011-212

MAINTENANCE

Air Filter

If the engine seems weak, produces black smoke or runs unevenly, the air filter may be clogged. For this reason, it is important to clean and replace the air filter regularly (see the maintenance schedule for the proper service interval).



WARNING!

Allow the exhaust system to cool before performing service. Risk for burns.

For cleaning or replacement:

1. Undo the wing nut (1) and lift off the cyclone filter with the air filter cowling (2).

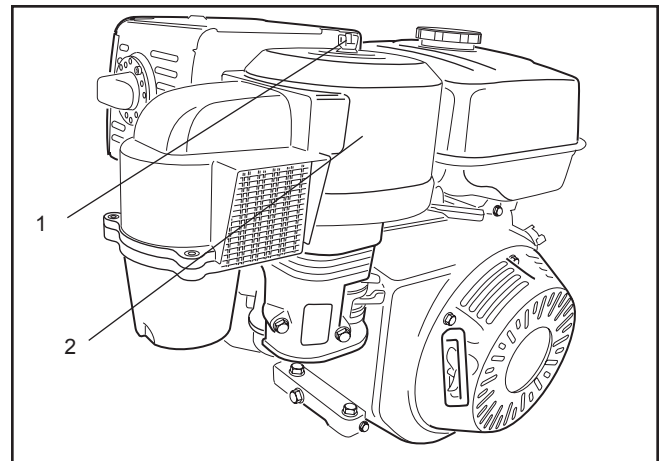

8011-126

2. Remove the foam rubber pre-filter and clean using a mild detergent. Squeeze dry with a clean cloth. Soak it with new engine oil. Wind the filter in an absorbent cloth and squeeze out excess oil.

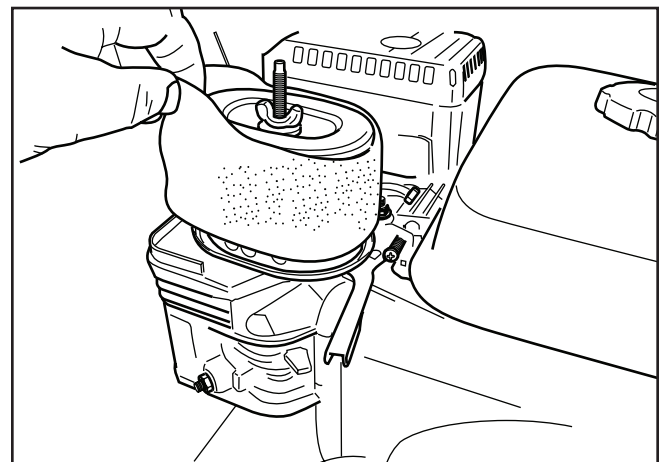

8011-030

MAINTENANCE

3. Remove the wing nut in the air filter and remove the paper filter.

IMPORTANT INFORMATION

DO NOT use compressed air over 2 bar/30 PSI to clean the paper filter.

DO NOT wash the paper filter.

DO NOT oil the paper filter.

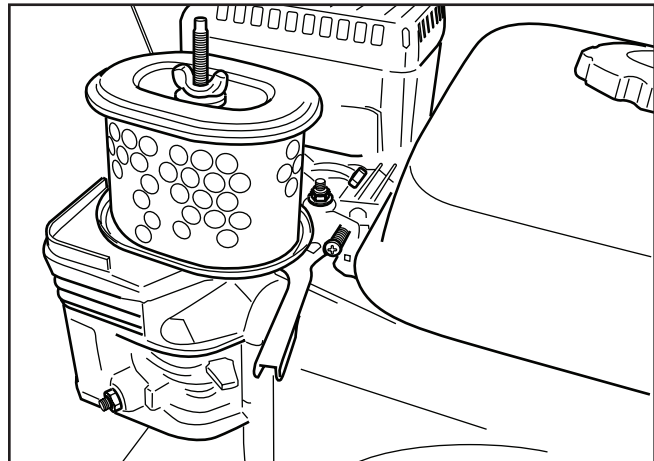

8011-031

4. Tap the paper filter against a fixed surface to remove dust. If the paper filter is still dirty or damaged, it **must** be replaced.
5. Mount the paper filter in the air filter housing and tighten the wing nut.
6. Refit the pre-filter on the paper filter.
7. Refit the cyclone filter with the air filter cowl.

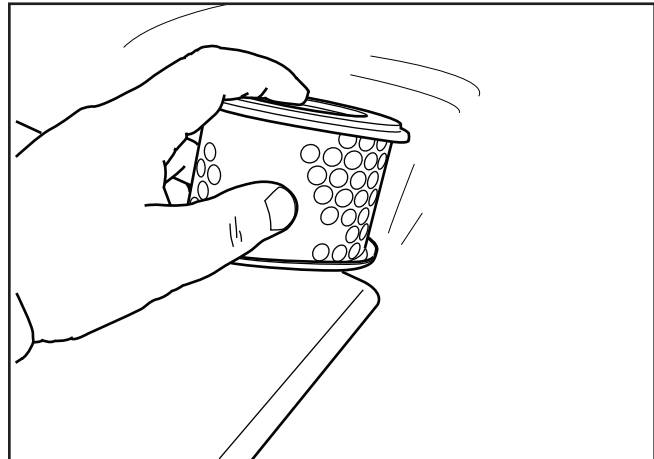

8011-032

Sludge Reservoir

1. Close the fuel valve.

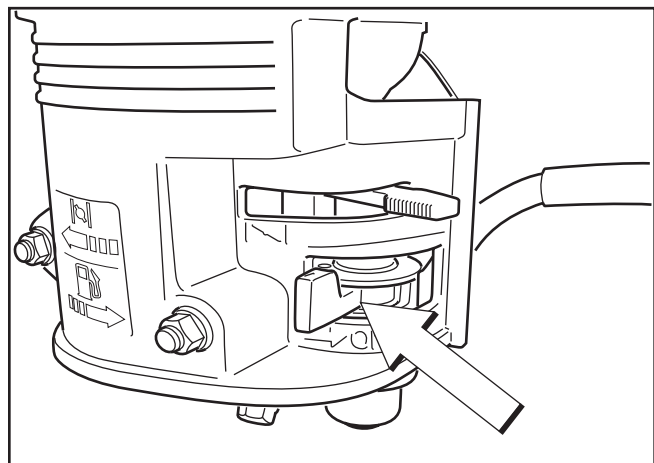

8060-024

MAINTENANCE

2. Unscrew the sludge reservoir (1). Make sure not to misplace the o-ring (2).
3. Clean the reservoir and the o-ring using a cleaning solvent and dry carefully.
4. Put the o-ring in place in its track and replace the sludge reservoir. Tighten it moderately to avoid damaging the threads.
5. Turn the fuel valve to ON and check for leaks. If it leaks, replace the o-ring.

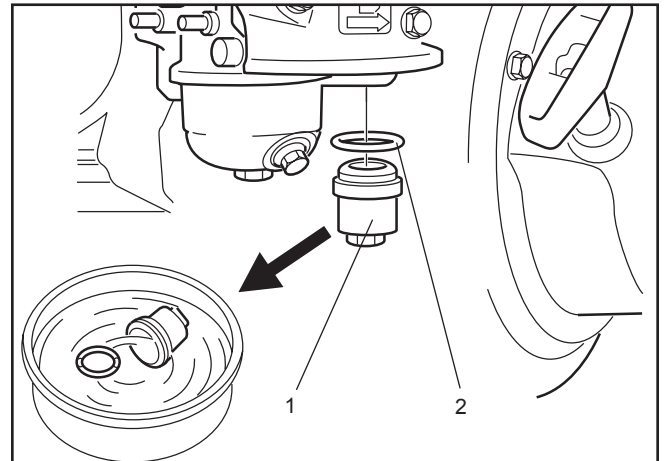

8011-128

Idle Adjustment



WARNING!

**Risk for carbon monoxide poisoning.
Perform the adjustment outdoors.**

1. Start the engine and run it until it reaches normal working temperature.
2. Adjust the throttle to idle position or so that the engine runs at the lowest possible speed.
3. Turn the idle screw so that the engine idles at 1250-1550 RPM.
4. Increase the idle speed with the throttle and move it right back to idle position. Check engine speed again.

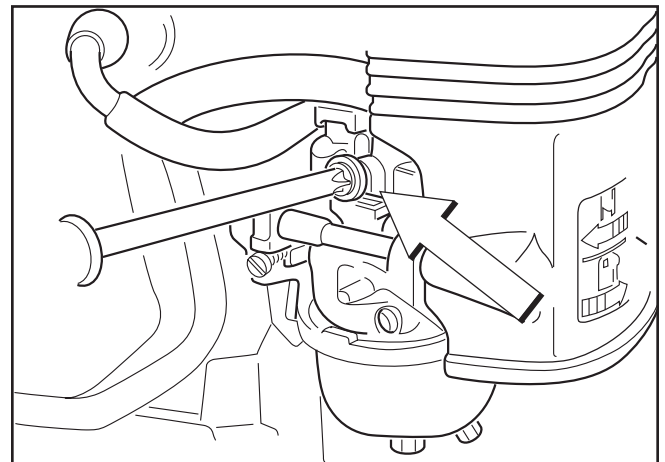

8011-128

MAINTENANCE

Ignition System

The engine is equipped with an electronic ignition system. Only the spark plug requires maintenance. For recommended spark plug, see "Technical data".

IMPORTANT INFORMATION

Fitting the wrong spark plug type can damage the engine.

1. Remove the ignition cable shoe and clean around the spark plug.
2. Remove the spark plug with a $1\frac{3}{16}$ " (21 mm) spark plug socket wrench.
3. Check the spark plug. Replace the spark plug if the electrodes are burned or if the insulation is cracked or damaged. Clean the spark plug with a steel brush if it is to be reused.
4. Measure the electrode gap with a gapping tool. The gap should be 0.7-0.8 mm/0.028-0.031". Adjust as necessary by bending the side electrode.
5. Reinsert the spark plug, turning by hand to avoid damaging the threads.

IMPORTANT INFORMATION

Inadequately tightened spark plugs can cause overheating and damage the engine. Tightening the spark plug too much can damage the threads in the cylinder head.

6. After the spark plug is seated, tighten it using a spark plug wrench so that the washer is compressed. A used spark plug should be turned $\frac{1}{8}$ - $\frac{1}{4}$ of a turn from the seated position. A new spark plug should be turned $\frac{1}{2}$ a turn from the seated position.
7. Replace the ignition cable shoe.

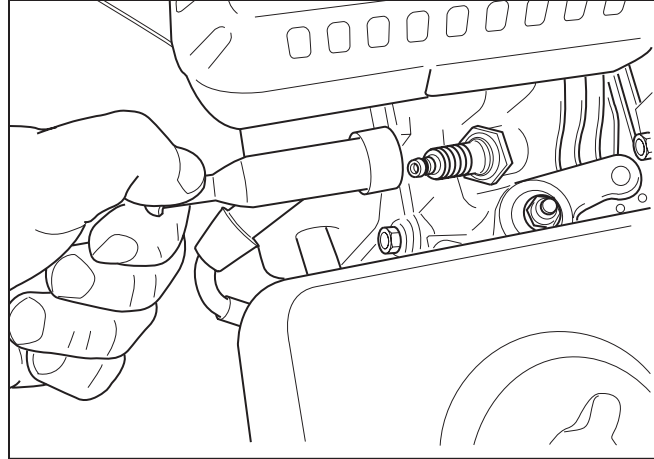

8011-027

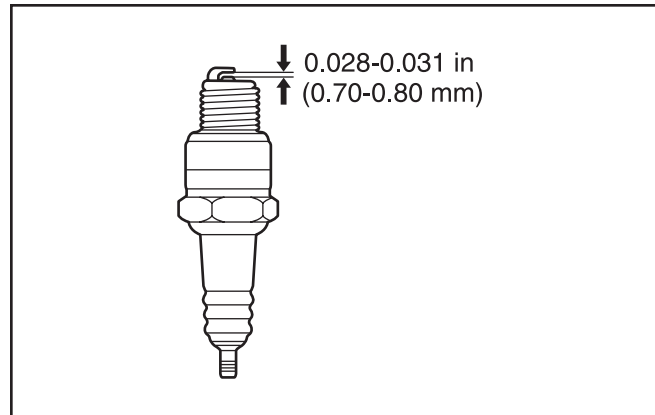

8011-054

MAINTENANCE

Drive Belt

1. Remove the belt guard by removing the three acorn nuts and lockwashers on the front of the belt guard.



WARNING!

Prevent the engine from being started by removing the ignition cable from the spark plug.

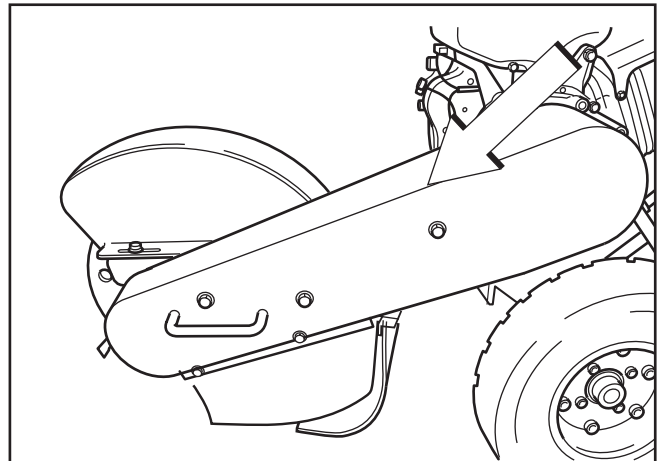

8060-226

2. Check that the belt is properly tensioned by squeezing the belt together. It should be possible to squeeze the belt down about $\frac{1}{4}$ - $\frac{3}{8}$ " (6 - 10 mm) from the original position.
3. Loosen screws holding cover plate to belt guard backing plate.

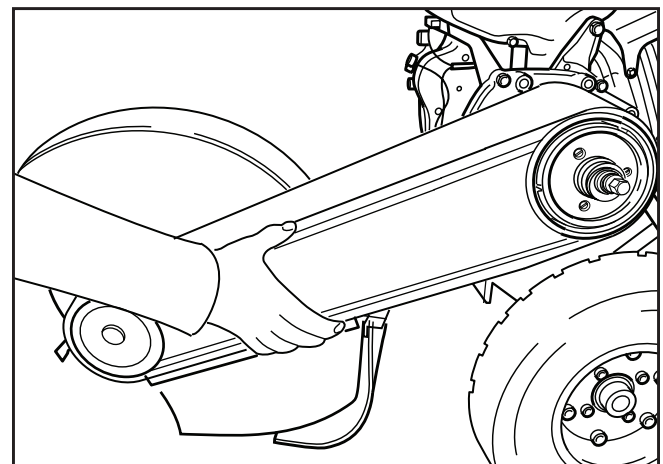

8060-227

4. Undo the two screws (A) on each side of the cutting shroud.

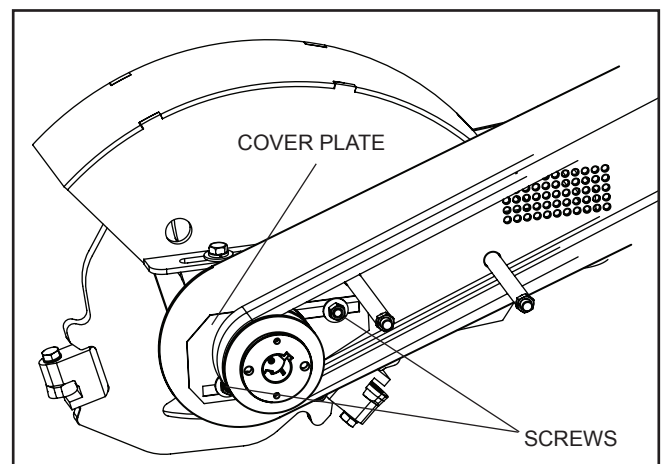

8062-006

MAINTENANCE

5. Loosen the locking nuts (B) on the two tension bolts.
6. Turn the two tension bolts (C) counter-clockwise to loosen the belt or clockwise to tighten it.

IMPORTANT INFORMATION

If pulley on cutter head shaft must be moved, the set screws **MUST** be fully removed, fresh "Loctite 242" put on threads and re-torqued to 100 - 110 in./lbs. (17513 / 19264 N•m).

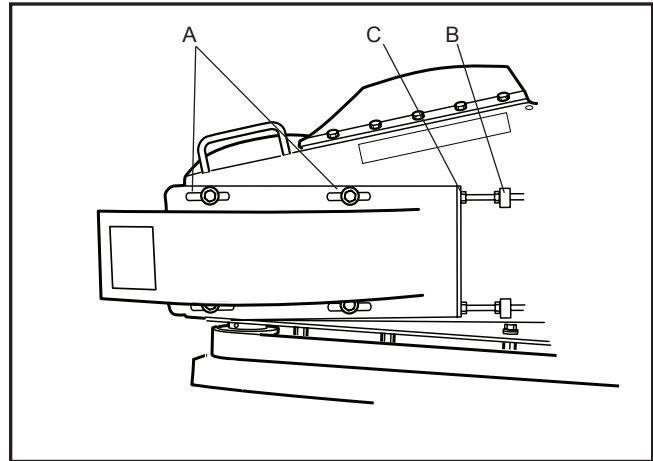

8011-228

7. Check that the pulleys are aligned using a straight edge along the inside face of the clutch and pulley. Pulleys must be inline. Maximum gap or misalignment is $\frac{1}{16}$ " (.062) or 15.7 mm. Adjust using the tension bolts as necessary. Check belt tension again.
8. Tighten all screws and nuts when the adjustment is complete. Be certain cover plate is not rubbing against cutter wheel shaft.
9. Refit the belt guard.

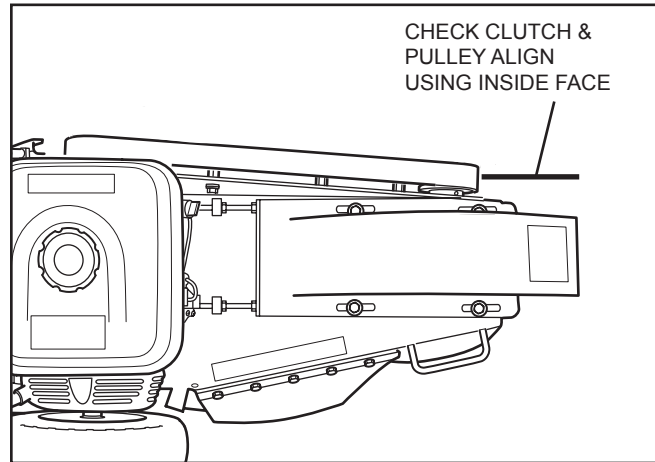

8011-229

Cutting Wheel



WARNING!

The cutters can come loose from the cutting wheel if the bolts are not sufficiently tight. Comply with the recommended torque settings.

Tighten the screws 30 ft/lbs. (133 Nm).

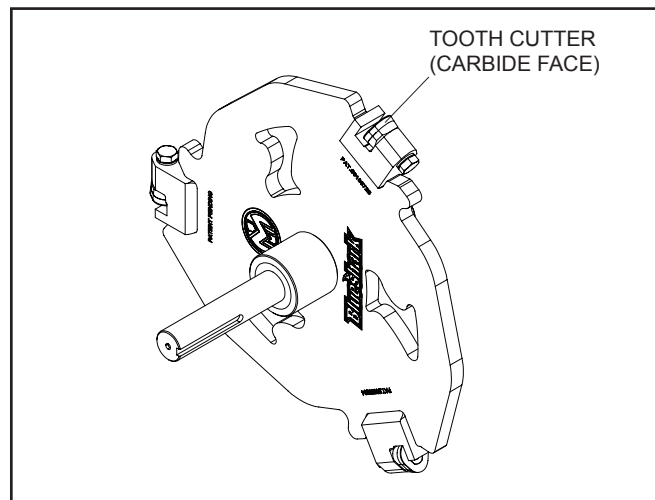

MAINTENANCE

Removing/Refitting Wheels

Left Wheel

To remove the left wheel (1) from the stump grinder, remove the locking collar (2), the ¼" screws (3), the ¼" hex nuts (3), the springs (4) and the brake pad (5). The wheel can now be removed from the axle.

Right Wheel

To remove the right wheel (6), remove the locking collar (7) and slide the wheel off the axle.

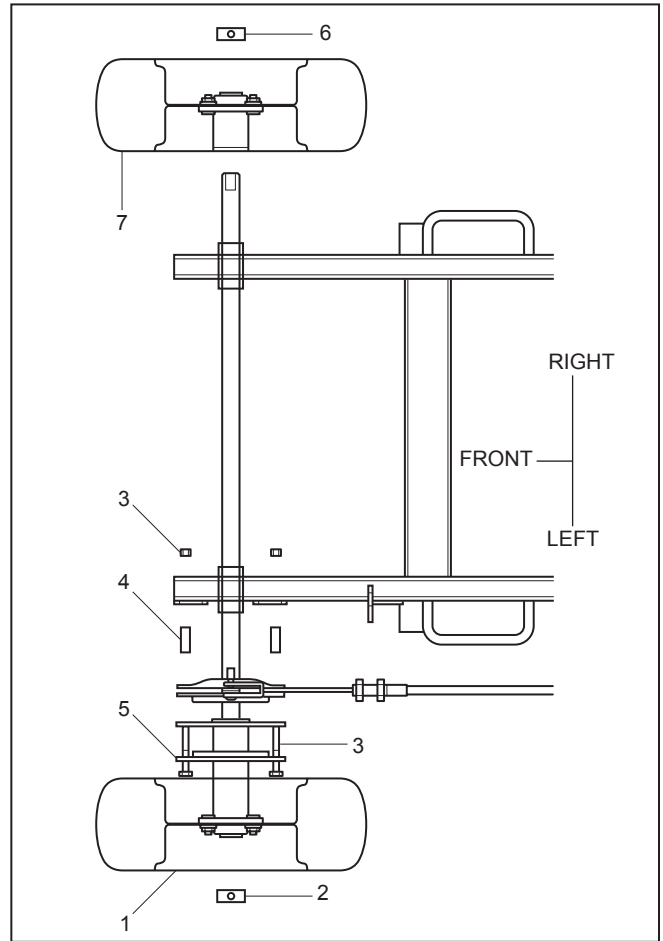

8011-217

Brake Adjustment

Overcentering type handle activities brakes.

Undo clevis pin from brake and turn clockwise to tighten brake or counter clockwise to loosen.

Tighten so handle snaps down when locked but unlocks easily when handle is moved forward. Brake is properly adjusted when wheel will not turn when you try to push or pull unit.

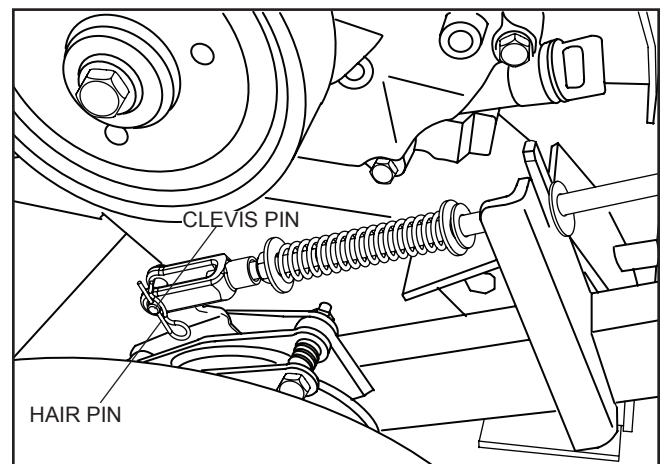

MAINTENANCE

Two Minute Rule

The machine may be tipped backward or on its side to facilitate access for cleaning or service, but no longer than 2 minutes.

If the machine is held in this position for too long, the engine can be damaged by gasoline draining into the crankcase. Should this happen, perform an extra oil change on the engine. Remove the spark plug and turn the engine over a few revolutions with the starter handle before starting the engine again.

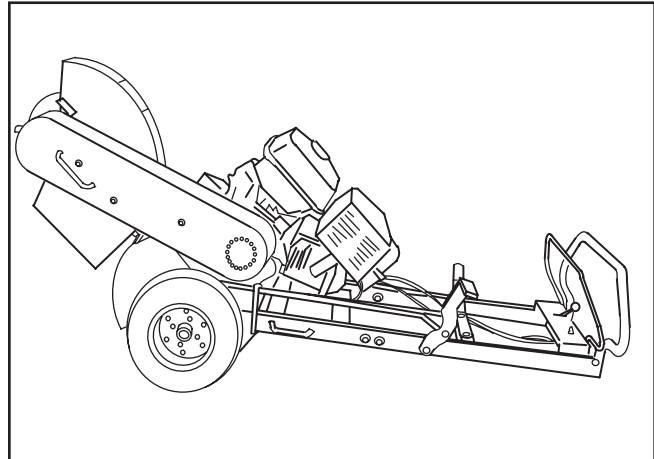

8064-007

Cleaning

Regular cleaning and washing will increase the machine's lifespan. Make it a habit to clean the machine directly after use, before the dirt sticks.

Check before rinsing that the fuel tank lid is properly in place to avoid getting water in the tank.

Use caution when using high-pressure spray because warning decals, instruction signs and the engine can be damaged. **Do not exceed 70 bar/1000 PSI water pressure when cleaning.**

Lubricate the machine after cleaning. This is particularly important if the machine is to be stored.

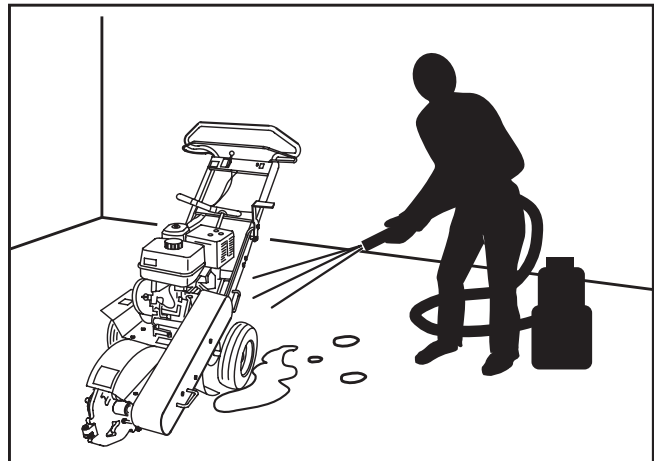

8011-210c

LUBRICATION

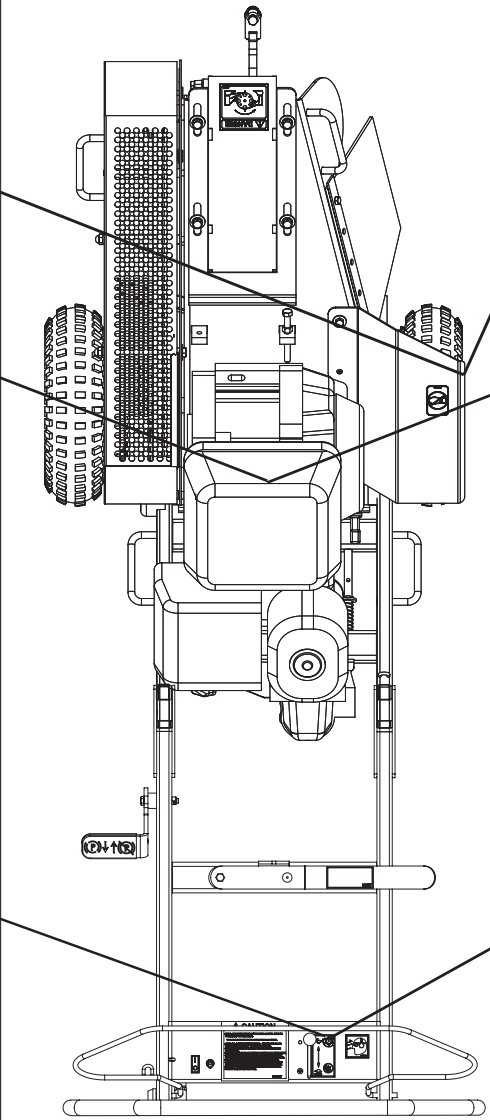
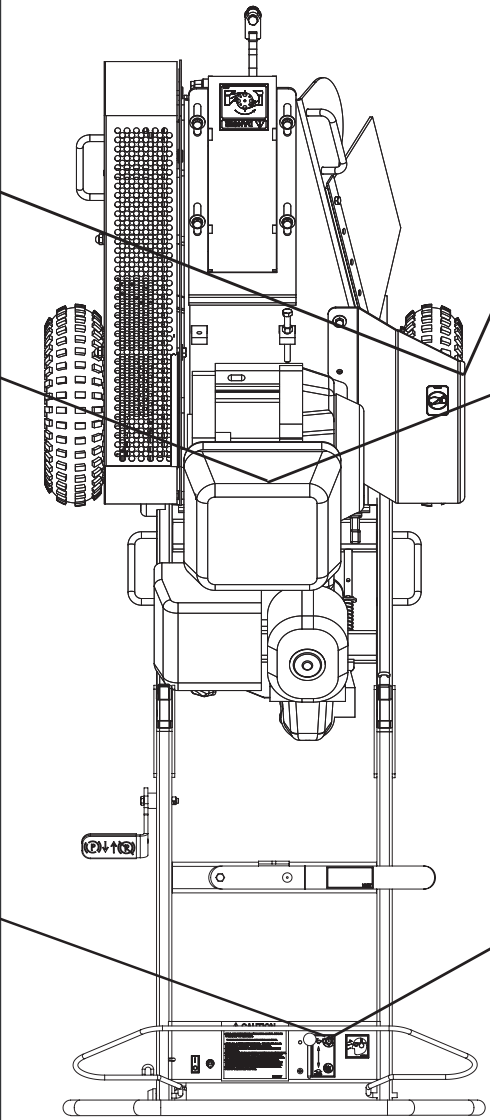
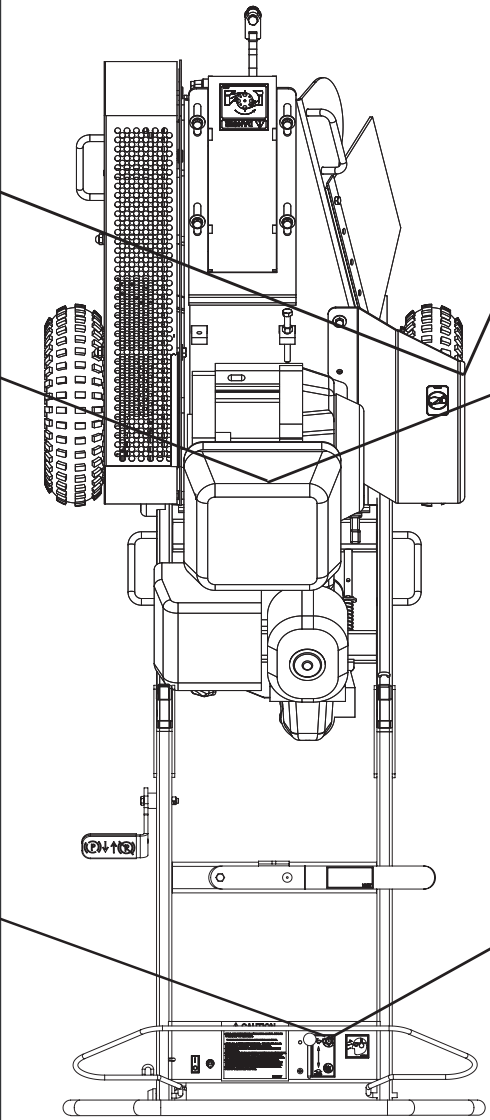
Yearly	6 Months	Wkly	Daily		4 Hours	50 Hours	100 Hours	300 Hours
	(←)			1		1	(←)	
	(∇)		👁️	2		2	(∇)	
(🛢️)				3		3	(🛢️)	

LUBRICATION

Engine Oil

The engine should be warm (but not hot) when changing the oil. Warm oil flows out faster and leaves a smaller quantity of old oil inside the engine.

1. Place a suitable container underneath the oil drainage screw. Remove the oil dipstick and the oil drainage screw on the back surface of the engine.

Tip: Make a channel using a piece of cardboard to lead the oil directly into the container to avoid soiling the machine chassis.

2. Allow the engine oil to drain into the container; then replace the drainage screw. Tighten it moderately.

IMPORTANT INFORMATION

Used engine oil is a health hazard and legislation prohibits disposal on the ground or in nature; it should always be disposed of at a workshop or appropriate disposal location. Avoid skin contact; wash with soap and water in case of spills.

3. Make sure the machine is parked on flat ground. Fill with new oil using the appropriate viscosity according to the diagram, API Service SF-SG, to the upper level mark on the dipstick = threads on the oil dipstick. The engine takes 1.16 qts. (1.1 liters) of oil. When checking the oil level, the dipstick should **not** be screwed in.
4. Check that the rubber gasket is in position and screw the dipstick back into place. **DO NOT** tighten it askew or too hard or you may damage the threads.
5. Wipe up any spilled oil.



WARNING!

Engine oil can be very hot if it is drained directly after stopping the machine. Allow the engine to cool for approximately 2 minutes.

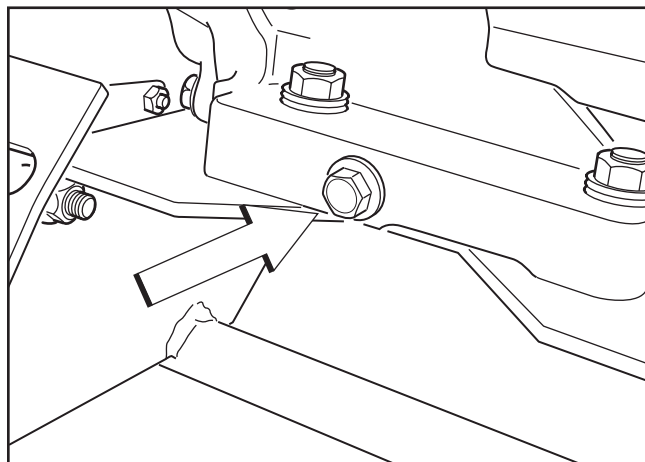

8011-187

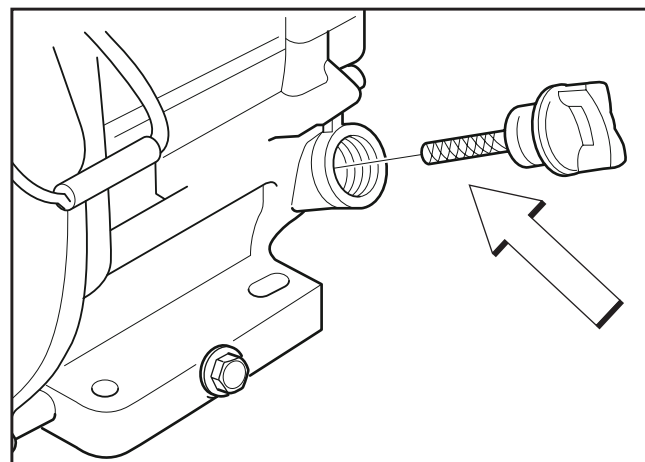

8060-028

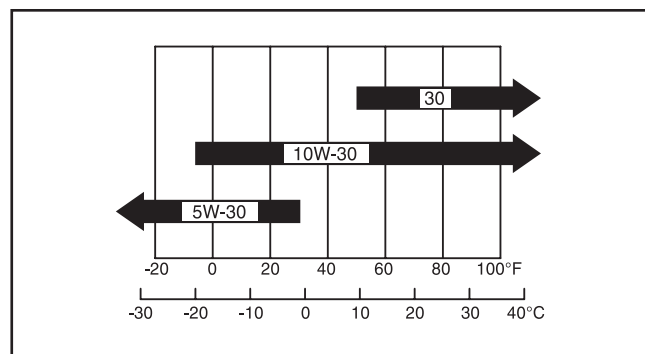

8011-046

LUBRICATION

Checking Engine Oil Level

Make sure that the machine is parked on flat ground with the engine stopped when checking the oil level.

1. Unscrew the dipstick and wipe it using paper towel or a lint-free rag.
2. Replace the dipstick without screwing it in. Remove and check the level on the dipstick.
3. Fill oil as necessary to the lip of the dipstick hole. Oil type, see above.
4. Check that the rubber gasket is in position and screw the dipstick back into place. **DO NOT** tighten it askew or too hard or you may damage the threads.

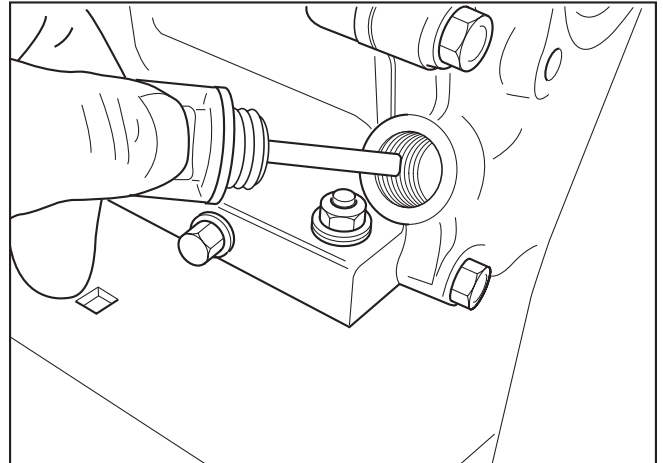

8011-020

Right wheel

Lubricate using a grease gun until the grease squeezes out one nipple.

Use good quality MP grease. Grease from well-known brand names (petrochemical companies, etc.) usually maintains a good quality.

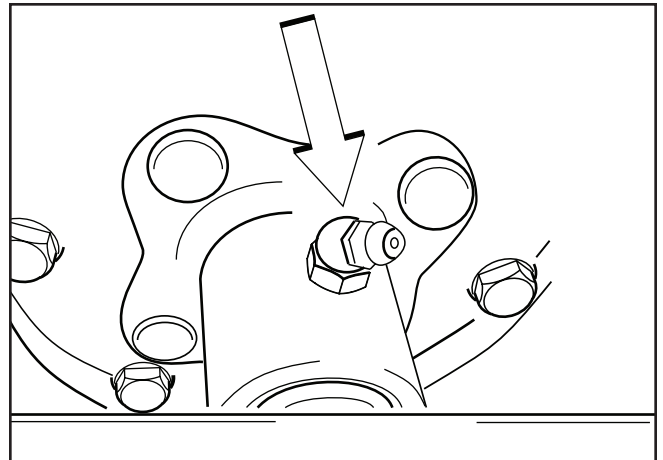

8011-231

Throttle cable

Peel back the rubber covers at both of the cable mountings. Grease both ends of the throttle cable and move the controls to end stop positions when lubricating. Refit the rubber covers on the cable after lubrication. Cables with sheaths will bind if they are not lubricated regularly. Binding in a cable may cause malfunction.

If the cable binds, remove the cable and hang it vertically. Lubricate it with thin engine oil until the oil begins to escape from the bottom.

Tip: Fill a small plastic bag with oil and tape it so that it seals against the casing and allow the cable to hang vertically from the bag overnight. If you do not succeed in lubricating the cable, it must be replaced.

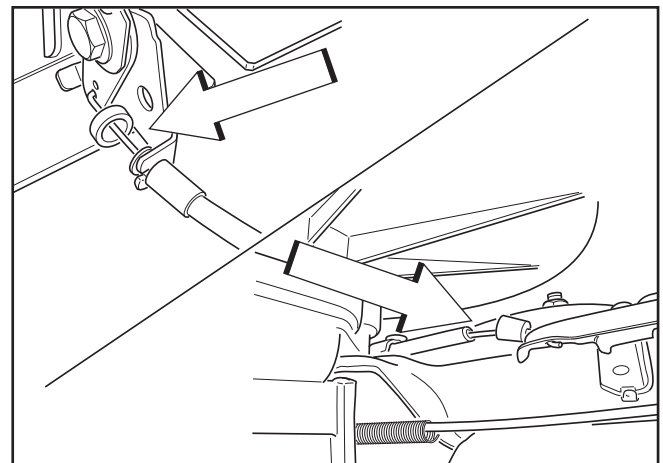

8011-234

TROUBLESHOOTING

PROBLEM	CAUSE	ACTION
Engine will not start		
User error	Fuel valve closed Choke valve open Engine switch in OFF position	Open the fuel valve Close the choke with cold engine Turn the engine switch to ON
Fuel system	Fuel tank empty Machine stored without observing proper procedure from chapter "Storage/Winter storage" Contamination, water or ice in fuel system Carburetor problems	Fill with fuel Clean tank, sludge reservoir and empty carburetor, fill the tank with fresh fuel Clean tank, sludge reservoir and empty carburetor, fill the tank with fresh fuel Contact an authorized service workshop
Spark plug	Wrong spark plug type Build-up on electrodes, short circuit Gasoline or oil on the spark plug Loose spark plug	Replace the spark plug Check electrode gap and clean or replace spark plug Clean the spark plug, air the engine out and start with full throttle Check spark plug connection
No spark after checking spark plug	Faulty engine switch, cable or ignition	Contact an authorized service workshop
Low compression	Serious interior engine damage or faulty valves	Contact an authorized service workshop
Engine is weak or runs unevenly		
Air filter	Clogged air filter	Clean or replace the air filter
Fuel system	Machine stored without observing proper procedure from chapter "Storage/Winter storage"	Clean tank, sludge reservoir and empty carburetor, fill the tank with fresh fuel
Blue or blue-white exhaust	Contaminated or incorrect fuel	Clean tank, sludge reservoir and empty carburetor, fill the tank with proper fuel
Black exhaust	Choke left on Clogged air filter Carburetor problems	Open choke valve Clean or replace the air filter Contact an authorized service workshop
Ignition system	Wrong spark plug type Build-up on electrodes, short circuit Faulty ignition unit	Replace the spark plug Check electrode gap and clean or replace spark plug Contact an authorized service workshop
Low compression	Serious interior engine damage or faulty valves	Contact an authorized service workshop

TROUBLESHOOTING

PROBLEM	CAUSE	ACTION
Belt comes off		
	Pulleys not aligned Belt tension is insufficient	Adjust belt tension
Belt engages late or slips		
		Tighten the belt as described in the operator's manual Reduce cutting depth
Belt not staying tight after adjustment		
	Damaged axle, pulley or key	Replace damaged parts Make sure the setscrews are properly tightened
Cutting wheel does not rotate		
	Engine speed is insufficient to activate the centrifugal clutch Belt tension is insufficient Clutch is worn	Make sure the throttle cable is working properly Adjust belt tension Replace shoes and springs, and/or clutch bearings
Cutting wheel continues to rotate	The engine speed is not under 1000 rpm, which is required to disengage the centrifugal clutch	Check for damage on the throttle cable Check that the throttle cable is properly mounted on the throttle valve Inspect springs on clutch shoes, if tension on clutch shoes is not enough to pull shoes back, replace springs and clutch shoes
Parking brake slips		
		Adjust the brake tension in the manner described in the operator's manual Check for damage on the brake rod or lever Check for wear on the brake pads. replace as necessary

STORAGE

Winter Storage

At the end of the season, the machine should be readied for storage (or if it will not be in use for longer than 30 days). Fuel allowed to stand for long periods of time (30 days or more) can leave sticky residues that can plug the carburetor and disrupt engine function.

Fuel stabilizers are an acceptable option as regards sticky residues during storage. If alkylate gasoline (Aspen) is used, stabilizers are unnecessary because this fuel is stable. However, you should avoid switching between regular and alkylate gasoline as sensitive rubber components can harden. Add stabilizer to the fuel in the tank or in the storage container. Always use the mixing ratios specified by the manufacturer of the stabilizer. Run the engine for at least 10 minutes after adding the stabilizer so that it reaches the carburetor. **DO NOT** empty the fuel tank and the carburetor if you have added stabilizer.

Service

When ordering spare parts, please specify the purchase year, model, type, and serial number.

Always use genuine Husqvarna parts.

An annual check-up at an authorized service workshop is a good way to ensure that your machine performs its best the following season.

To ready the machine for storage, follow these steps:

1. Clean the machine carefully, particularly the chassis and working equipment. Touch up damage to the paint to prevent rust.
2. Inspect the machine for worn or damaged parts and tighten any nuts or screws that may have become loose.
3. Change the engine oil; dispose of properly.
4. Open the fuel valve. Empty the fuel tank (1) and the carburetor (2).
5. Close the fuel valve.
6. Remove the spark plug and pour about a tablespoon of engine oil in the cylinder. Turn over the engine so that the oil is evenly distributed and then refit the spark plug. Put the engine in the compression phase where the triangle mark on the sleeve of the starter is aligned with the upper hole in the starter. Note: Compression phase occurs every second revolution.
7. Lubricate all grease nipples, joints and cables as described in *Lubrication*.
8. Store the machine in a clean, dry place and cover it for extra protection.
9. Cover the blade and cutters with a thin coat of oil to avoid rust.



WARNING!

NEVER store an engine with fuel in the tank indoors or in poorly ventilated spaces where fuel vapor can come in contact with open flame, sparks or a pilot light such as in a boiler, hot water tank, clothing drier, etc. Handle the fuel with caution. It is very flammable and careless use can cause serious damage to person and property. Drain the fuel into an approved container outdoors and far away from open flame. **NEVER** use gasoline for cleaning. Use a degreaser and warm water instead.

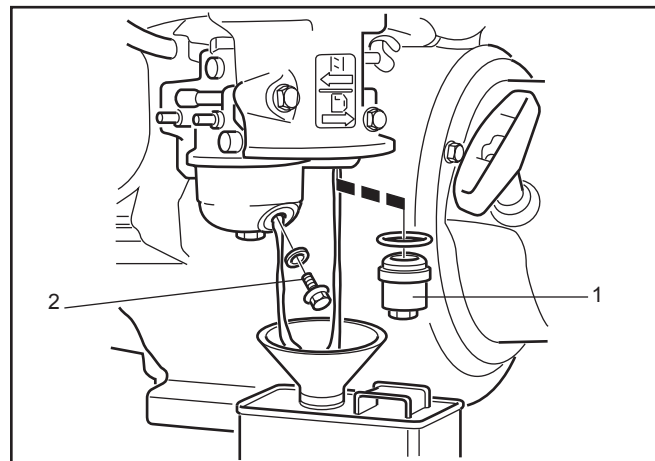

8011-130

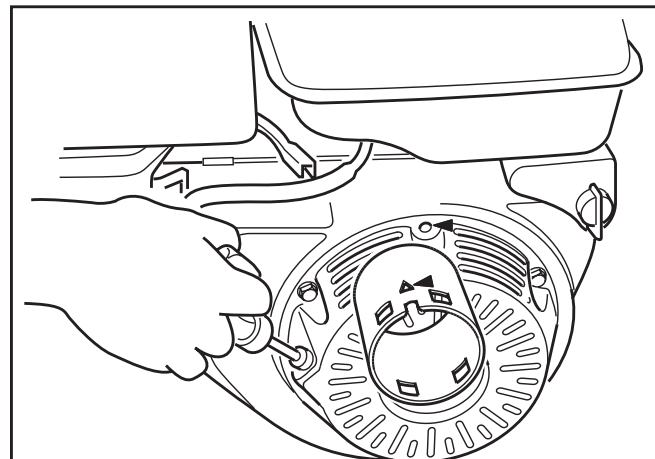

8011-131

TECHNICAL DATA

	Model SG13B / 966042601
Engine	
Manufacturer	Honda
Cylinder Volume	337 cc (20.6 cu in)
Power	13 hp (9.2 kW at 3600 RPM)*
Torque	17.36 ft-lb / 2.4 kg-m at 2500 RPM
Idling speed	1250-1550 RPM
Oil capacity including filter	2.2 qt / 2.1 liter
Spark plug	NGK BP6ES or BPR6ES
Fuel tank volume	1.7 gal. / 6.5 L
Chassis	
Tires	4.10-6 (12" pneumatic)
Brake	Disk - Lever activated
Drive	Direct
Belt	Dayco double V-belt
Clutch	Amsbeck or Noram centrifugal clutch
Cutting Wheel	14" dia. x 3/8" thick disc (157.5 mm x 9.5 mm)
Cut Depth	Approx 10" (25.4 cm)
Dimensions	
Length	62"- 73" (157- 185 cm) depending on handle position
Width	27" (69 cm)
Height	24"- 43" (61 - 109 cm) depending on handle position
Weight	249 lb. (112.9 kg)

SCHEMATICS

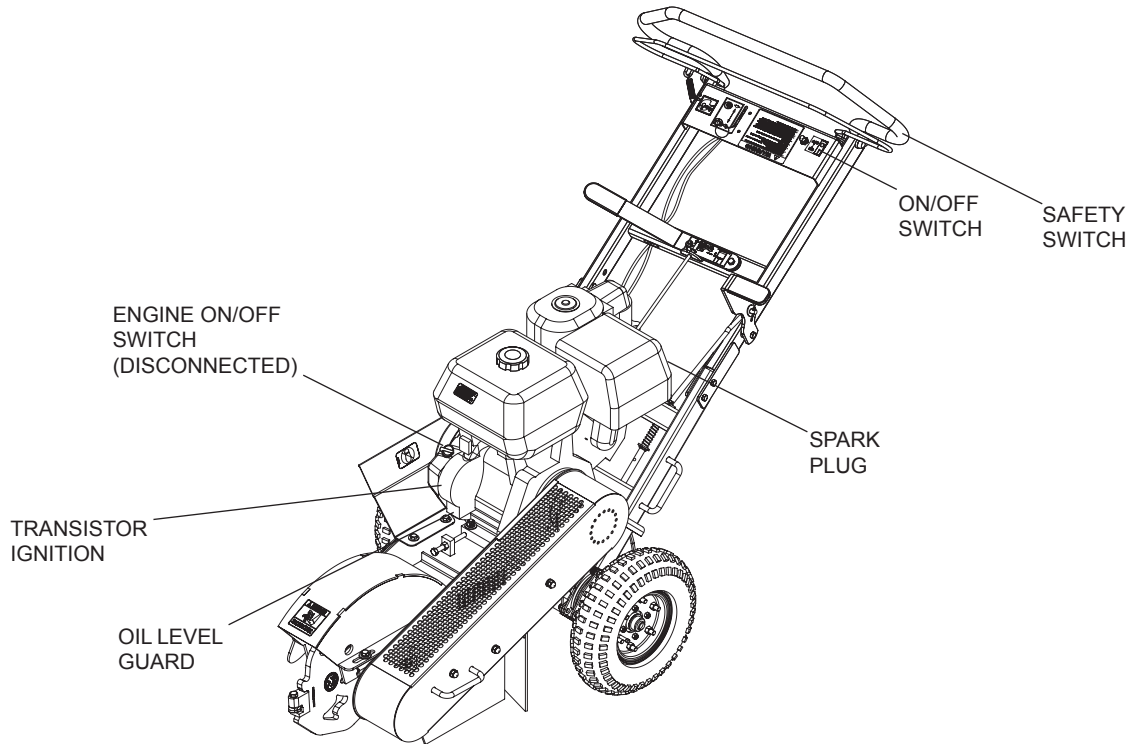

8064-008

ENGINE HARNESS

CONSOLE HARNESS

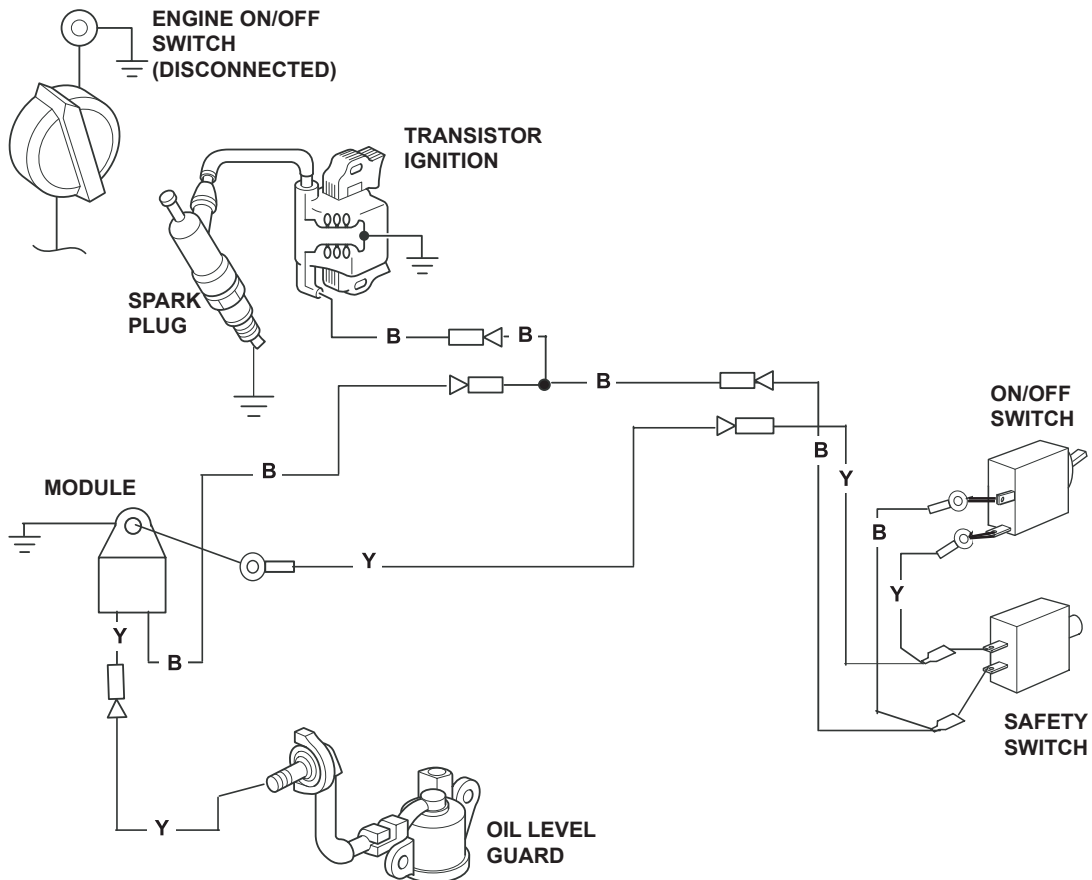

COLOR CODE
Y - YELLOW
B - BLACK

8064-009

SERVICE JOURNAL

Action

Date, stamp, signature

Delivery service

1. Open packaging and make sure machine has not been damaged in transport.
2. Where applicable, assembly accompanying components.
3. Check that machine design corresponds to customer order.
4. Check that right amount of oil is in engine and transmission.
5. Check and adjust air pressure in tires. (25 psi max.)
6. Check that working equipment is properly set.
7. Check drive pulleys and sprockets for alignment.
8. Check belts and chains for proper adjustment.
9. Lubricate the machine as described in the lubrication schedule.
10. Fill fuel tank and start engine.
11. Check that machine and working equipment do not move in neutral.
12. Check all operating instruments.
13. Check decals and information attached to unit.
14. Check engine speed (RPM), see Technical Data.
15. Check for leakage.
16. Inform the customer about:
 - The need and advantages of following the service schedule.
 - The need and advantages of leaving the machine for service every 300 hours.
 - The effects of service and maintaining a service journal on the machine's resale value.
17. Fill in the sales papers, etc.

Delivery service has been carried out.

No remaining notes.

Certified:

After the first 20 hours

1. Change engine oil.
2. Change oil in reduction gear, where applicable.
3. Check that belts and chains are properly adjusted.
4. Tighten screws and nuts.



HUSQVARNA PRODUCT REGISTRATION INFORMATION & WARRANTY STATEMENT

All Husqvarna products can be registered online at www.usa.husqvarna.com quickly and easily regardless of their model year. Click the Support tab, then click on the Online Product Registration link, and fill out the electronic form and submit. Ask about Husqvarna's extended service plan!

SECTION 1: LIMITED WARRANTY

Husqvarna Professional Products, Inc ("Husqvarna") warrants the original purchaser the Husqvarna branded product to which this warranty apply (the "Product") that the Product shall be free from defects in material and workmanship from the date of purchase for the period of the applicable "Warranty Schedule" of the Product as set forth below. Additional limitations are described in Section 2 through 6, inclusive.

PRODUCT CATEGORY	CONSUMER WARRANTY SCHEDULE*	COMMERCIAL / PROFESSIONAL WARRANTY SCHEDULE	RENTAL WARRANTY SCHEDULE
Reconditioned Products: Reconditioned chainsaws, trimmers, brushcutters, clearing saws, handheld blowers, backpack blowers, hedge trimmers, and electrical products.	90 Days	N/A	N/A
Chain Saws Lifetime Ignition Warranty (Parts Only). One Year Conditional Crankshaft Warranty for Commercial/Professional use when operated with Husqvarna XP 2 cycle oil (Parts & Labor).	2 Years	90 Days	90 Days
100 Series Trimmers, Stick Edgers, Hedge Trimmers Lifetime Ignition Warranty (Parts Only). Lifetime Shaft Warranty.	2 Years	1 Year	90 Days
200 & 300 Series Trimmers, Brushcutters, Clearing Saws, Stick Edgers, Hovering Trimmers & Hedge Trimmers Lifetime Ignition Warranty (Parts Only) and Lifetime Shaft Warranty apply to these products (excludes Hovering Trimmers).	2 Years	1 Year	90 Days
Blowers (Lifetime Ignition Warranty - Parts Only)	2 Years	2 Years	90 Days
Pole Pruners, Pole Saws, Pole Hedge Trimmers (Lifetime Ignition Warranty - Parts Only)	1 Year	1 Year	90 Days
Residential Walk-Behind Mowers, Tillers, LE389 Edger †	2 Years	N/A	N/A
LE475 Edger †	2 Years	90 Days	90 Days
LT, LTH, LS, XLS, GLS, YT, YTH, GT, GTH, 16H, Pro15, 155 ProFlex Series Lawn & Garden Riders and Residential Zero Turn Mowers †	2 Years	N/A	N/A
MZ and EZ Series Zero Turn Riders †	3 Years or 600 Hours	1 Year or 600 Hours	90 Days
iZ, LZ, BZ Series Zero Turn Riders † (Applies to units factory-equipped with Roll Over Protection System.)	5 Years or 1,500 Hours	5 Years or 1,500 Hours	90 Days
Commercial Walk Mowers † (includes 21" & wide area)	3 Years	3 Years	90 Days
Commercial Turf Specialty Equipment †	1 Year	1 Year	1 Year
Zero Turn & Commercial Turf Specialty Attachments	2 Years	1 Year	90 Days
Power Cutters (Lifetime Ignition Warranty - Parts Only)	1 Year	90 Days 1 Year (K750 only)	90 Days
Automatic Mower (1 Year Battery Warranty)	2 Years	90 Days	90 Days
Snow Throwers †	2 Years	90 Days	90 Days
Pressure Washers †	2 Years	2 Years (Excludes 5525PW)	N/A
Generators (Husqvarna's warranty does not cover Engine & Generator Parts, which are warrantied by responsible manufacturer.) †	2 Years (2 nd Year Parts Only)	2 Years – 1365GN only (2 nd Year Parts only)	N/A
Grass Catchers & Bumpers Purchased with New Units	Same Warranty As Unit When Purchased with Unit		
Spreaders	1 Year		
Parts & Accessories Purchased Separately	30 days		
Husqvarna Utility Vehicles** (Engines/transmissions shall be warrantied through Husqvarna.)	2 Year or 2,000 Hour Powertrain & 1 Year or 1,000 Hour Body Warranty		
HUV Batteries: 4210E Versions	4 Year Pro-rated		
Husqvarna Safety Apparel***	90-day		
Batteries**** (Consumer Products where applicable)	1 year	N/A	
Replacement Parts, Accessories including Bars and Chains, Tools and Display Items. Emission Control System Components necessary to comply with CARB-TIER II and EPA Regulations (Excludes components which are part of engine systems manufactured by third part engine manufacturers for which the purchaser has received a separate warranty with product at time of purchase.)	30 Day Warranty		

† Refer to Section 3 for items not covered by this warranty

*All consumer product use must have been limited to the owner's residence. Warranted for noncommercial, nonprofessional, noninstitutional and nonincome producing use.

HUV 2 Year or 2,000 Hour Powertrain (The engine assembly, unitized transaxle assembly (gasoline vehicle), motor, and main frame assembly are warranted with respect to parts and labor against defects in material and workmanship or a period of two years or 2000 hours of operation, whichever first occurs, from the date of purchase.) & **1 Year or 1,000 Hour Body Warranty (All remaining components of the vehicle not specified otherwise and all other original equipment options and accessories supplied by Husqvarna are warranted with respect to parts and labor against defects in material and workmanship for a period of one year or 1000 hours of operation, whichever first occurs, from the date of purchase.)

HUV's Gas & Diesel Powered Battery: 0 – 6 months free replacement and 7 – 12 months prorated

HUV's Electric Powered – 4 year or 16,000 Energy Unit Limited Warranty Period

***Husqvarna safety apparel warranty is from the date of the customer's original purchase for defects in material and workmanship. Normal wear, tear or abuse is not covered under warranty. All care and maintenance instructions must be followed as stated by the manufacturer on the care label. The fit of the protective apparel/boot is not covered under warranty.

****Battery 1 Year prorated limited warranty with 100% replacement during the first 6 months.

Lifetime Warranty (Parts and Labor): All tiller tines and trimmer shafts against breakage. Proof of purchase required.

Lifetime Warranty ("PARTS ONLY" after initial warranty expiration): Ignition coils and modules on handheld product. Proof of purchase required.

SECTION 2: HUSQVARNA'S OBLIGATIONS UNDER THE WARRANTY

Husqvarna will repair or replace defective components without charge for parts or labor if a component fails because of a defect in material or workmanship during the warranty period.

SECTION 3: ITEMS NOT COVERED BY THIS WARRANTY

The following items are not covered by this warranty:

- (1) Normal customer maintenance items which become worn through normal regular use, including, but not limited to, belts, blades, blade adapters, bulbs, clutches, clutch drums, filters (fuel line, fuel filters, air filters, oil filters), sprockets, guide bars, lubricants, rewind springs, saw chain, spark plugs, starter ropes and tiller tines;
- (2) Natural discoloration of material due to ultraviolet light;
- (3) Engine and drive systems not manufactured by Husqvarna; these items are covered by the respective manufacturer's warranty as provided in writing with the product information supplied at the time of purchase; all claims must be sent to the appropriate manufacturer.
- (4) Lawn and garden attachments that are covered by a third party which gives a warranty, all claims for warranty should be sent to the manufacturer.
- (5) Commercial or consumer mowing decks with sand abrasion damage.
- (6) Emission Control System components necessary to comply with CARB-TIER II and EPA regulations which are manufactured by third party engine manufacturer.

SECTION 4: EXCEPTIONS AND LIMITATIONS

This warranty shall be inapplicable to defects resulting from the following:

- (1) Accident, abuse, misuse, negligence and neglect, including stale fuel, dirt, abrasives, moisture, rust, corrosion, or any adverse reaction due to incorrect storage or use habits;
- (2) Failure to operate or maintain the unit in accordance with the Owner's/Operator's manual or instruction sheet furnished by Husqvarna;
- (3) Alterations or modifications that change the intended use of the product or affects the product's performance, operation, safety, or durability, or causes the product to fail to comply with any applicable laws; or;
- (4) Additional damage to parts or components due to continued use occurring after any of the above.

REPAIR OR REPLACEMENT AS PROVIDED UNDER THIS WARRANTY IS THE EXCLUSIVE REMEDY OF THE PURCHASER. HUSQVARNA SHALL NOT BE LIABLE FOR ANY INCIDENTAL OR CONSEQUENTIAL DAMAGES FOR BREACH OF ANY EXPRESS OR IMPLIED WARRANTY ON THESE PRODUCTS EXCEPT TO THE EXTENT PROHIBITED BY APPLICABLE LAW. ANY IMPLIED WARRANTY OF MERCHANTABILITY OR FITNESS FOR A PARTICULAR PURPOSE ON THESE PRODUCTS IS LIMITED IN DURATION TO THE WARRANTY PERIOD AS DEFINED IN THE LIMITED WARRANTY STATEMENT. HUSQVARNA RESERVES THE RIGHT TO CHANGE OR IMPROVE THE DESIGN OF THE PRODUCT WITHOUT NOTICE, AND DOES NOT ASSUME OBLIGATION TO UPDATE PREVIOUSLY MANUFACTURED PRODUCTS.

Some states do not allow the exclusion of incidental or consequential damages, or limitations on how long an implied warranty lasts, so the above limitations or exclusions may not apply to you. This warranty gives you specific legal rights, and you may also have other rights which vary by state.

SECTION 5: CUSTOMER RESPONSIBILITIES

The product must exhibit reasonable care, maintenance, operation, storage and general upkeep as written in the maintenance section of the Owner's/Operator's manual. Should an operational problem or failure occur, the product should not be used. Failure caused by continued use is not covered by warranty. Product should be delivered, at owners expense, as is, to an authorized Husqvarna Servicing Retailer for evaluation. Proof of purchase, as explained in section 6, rests solely with the customer.

SECTION 6: PROCEDURE TO OBTAIN WARRANTY CONSIDERATION

It is the Owner's and Retailer's responsibility to make certain that the Warranty Registration Card is properly filled out and mailed to Husqvarna. This card should be mailed within ten (10) days from the date of purchase in order to confirm the warranty and to facilitate post-sale service. Proof of purchase must be presented to the authorized Husqvarna retailer in order to obtain warranty service. This proof must include date purchased, model number, serial number, and complete name and address of the selling retailer. To obtain the benefit of this warranty, the product believed to be defective must be delivered to an authorized Husqvarna retailer in a timely manner, no later than thirty (30) days from date of the operational problem or failure. The product must be delivered at the owner's expense. Downtime, pick-up and delivery charges are not covered by this warranty. An authorized Husqvarna retailer can be located by calling 1-800-HUSKY-62 or visiting www.husqvarna.com

Subject to change without notice.

HUSQVARNA 7349 Statesville Road, Charlotte, NC 28269

IR
Part Number 525 88 56-01

