

# Operator and Parts Manual

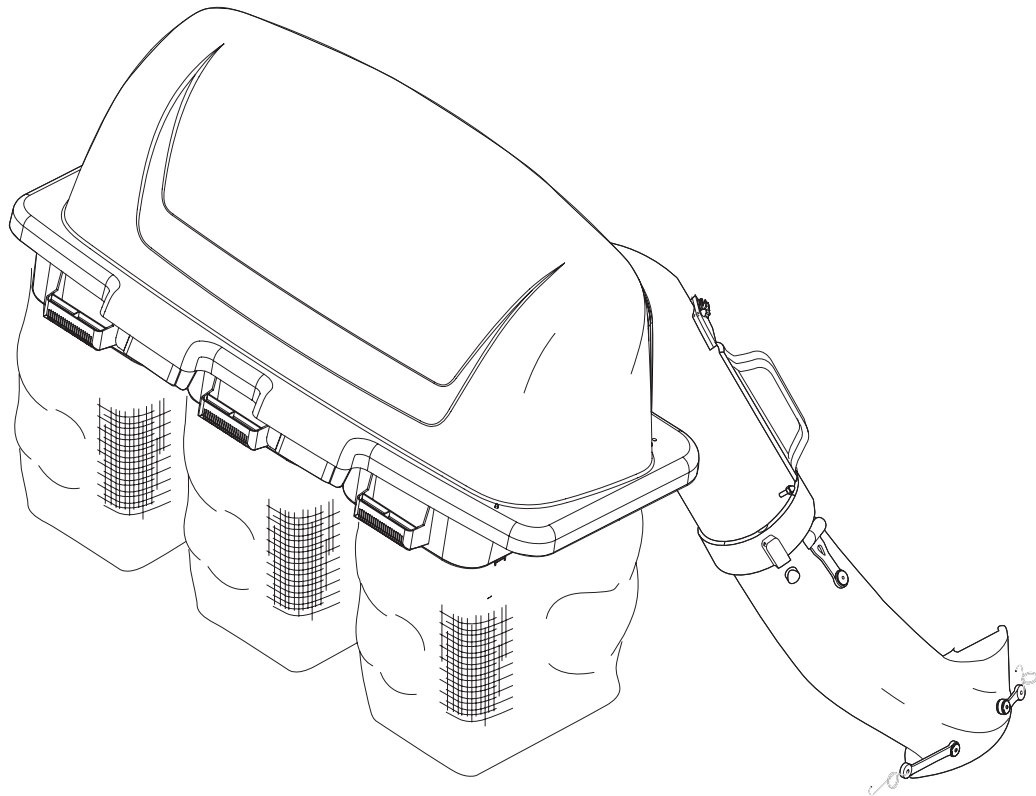

## Grass Catcher

**46" Stamped Deck / EZ Series**

Model 968 999732



# CONTENTS

---

SAFETY.....	4
CONTAINER CONTENTS.....	7
ASSEMBLY .....	8
OPERATION.....	12
CUSTOMER RESPONSIBILITIES.....	13
PARTS.....	14
TORQUE CHART.....	18

**CONGRATULATIONS** on your purchase of a new Grass Catcher. It has been designed, engineered and manufactured to give you the best possible dependability and performance.

Should you experience any problem you cannot easily remedy, contact the nearest authorized service center/department. They have competent, well-trained technicians and the proper tools for service and repairs.

Read and retain this manual. The instructions will enable you to assemble and maintain your collection system properly. Always observe the SAFETY RULES.

## **KNOW YOUR GRASS CATCHER**

READ THIS OPERATION MANUAL AND SAFETY RULES BEFORE ASSEMBLING OR OPERATING YOUR GRASS CATCHER. Compare the illustrations with the carton contents to familiarize yourself with the parts before starting the assembly. Study the operating instructions and safety precautions thoroughly to insure proper functioning of your Grass Catcher and to prevent injury to yourself and others. Save this manual for future reference.



### **WARNING**

The operation of any mower can result in foreign objects thrown into the eyes, which can result in severe eye damage. **ALWAYS wear safety glasses or eye shields before starting your mower and while mowing. We recommend a wide vision safety mask for over the spectacles or standard safety glasses.**

# SAFETY

---



## SAFE OPERATION PRACTICES FOR RIDE-ON MOWERS



### DANGER !

THIS CUTTING MACHINE IS CAPABLE OF AMPUTATING HANDS AND FEET AND THROWING OBJECTS. FAILURE TO OBSERVE THE FOLLOWING SAFETY INSTRUCTIONS COULD RESULT IN SERIOUS INJURY OR DEATH.

#### I. GENERAL OPERATION

- Read, understand and follow all instructions in the manual and on the machine before starting.
- Only allow responsible adults, who are familiar with the instructions, to operate the machine.
- Clear the area of objects such as rocks, stones, toys, wire etc., which could be picked up and thrown by the blades.
- Be sure the area is clear of all people and pets before mowing. Stop the machine if anyone enters the area.
- Never carry passengers or children even with blades off.
- Do not mow in reverse unless absolutely necessary. Always look down and behind before and while backing.
- Be aware of the mower discharge direction and do not direct it towards anyone. Do not operate the mower without either the entire grass catcher or the guard in place.
- Slow down before turning.
- Never leave the machine unattended when the engine is running. Always turn off the blades, set the parking brake, stop the engine and remove the key before leaving the machine.
- Turn off blades when not mowing.
- Stop engine before removing grass catcher or unclogging chute.
- Mow only in daylight or good artificial light.
- Do not operate the machine while under the influence of alcohol or drugs.
- Watch out for traffic when operating near or crossing roadways.
- Use extra care when loading and unloading the machine onto a trailer or truck.
- Data indicates that operators, age 60 years and above, are involved in a large percentage of riding mower-related injuries. These operators should evaluate their ability to operate the riding mower safely enough to protect themselves and others from serious injury.
- **DO NOT** operate mower with grass catcher, unless the front weights are installed.
- Keep machine free of grass, leaves or other debris buildup which can touch hot exhaust/engine parts and burn. Do not allow the mower deck to plow leaves or other debris which can cause buildup to occur. Clean any oil or fuel spillage before operating or storing the machine. Allow machine to cool before storage.

#### II. SLOPE OPERATION

Slopes are a major factor related to loss-of-control and tipover accidents, which can result in severe injury or death. All slopes require extra caution. If you cannot back up the slope or if you feel uneasy on it, do not mow it.

##### DO

- Mow up and down slopes (10° Max.), not across.
- Remove obstacles such as rocks, tree limbs, etc.
- Watch for holes, ruts, or bumps. Uneven terrain could overturn the machine. **Tall grass can hide obstacles.**
- Use slow speed. Choose a low speed so that you will not have to stop while on the slope.
- Use extra care with grass catchers or other attachments. These can change the stability of the machine.
- Keep all movement on the slopes **slow** and **gradual**. Do not make sudden changes in speed or direction.
- Avoid starting or stopping on a slope. If tires lose traction, disengage the blades and proceed slowly **straight** down the slope.

# SAFETY

---



## SAFE OPERATION PRACTICES FOR RIDE-ON MOWERS



### DO NOT

- **Do not** turn on slopes unless necessary, and then, turn slowly and gradually downhill, if possible.
- **Do not** mow near drop-off, ditches, or embankments. The mower could suddenly turn over if a wheel is over the edge of a cliff or ditch, or if an edge caves in.
- **Do not** mow on wet grass. Reduced traction could cause sliding.
- **Do not** try to stabilize the machine by putting your foot on the ground.

### III. CHILDREN

Tragic accidents can occur if the operator is not alert to the presence of children. Children are often attracted to the machine and the mowing activity. **Never** assume that children will remain where you last saw them.

- **NEVER allow children to operate the machine.**
- Keep children out of the mowing area and under the watchful care of another responsible adult.
- Be alert and turn off the machine if children enter the area.
- Before and when backing, look behind and **down** for small children.
- Never carry children. They may fall off and be seriously injured or interfere with safe machine operation.
- Use extra care when approaching blind corners, shrubs, trees, or other objects that may obscure vision.

### IV. SERVICE

- The operation of any mower can result in foreign objects thrown into the eyes, which can result in severe eye damage. Always wear safety glasses or eye shields while operating your mower or performing any adjustments or repairs. We recommend a wide vision safety mask over spectacles or standard safety glasses.

- Use extra care in handling gasoline and other fuels. They are flammable and vapors are explosive.
  - Use only an approved container.
  - Never remove gas cap or add fuel with the engine running.
  - Allow engine to cool before refueling.
  - Do not smoke.
  - Never refuel the machine indoors.
  - Never store the machine or fuel container inside where there is an open flame, such as a water heater.
- Never run a machine inside a closed area.
- Keep nuts and bolts, especially blade attachment bolts, tight and keep equipment in good condition.
- Never tamper with safety devices. Check for proper operation regularly.
- Keep machine free of grass, leaves, or other debris buildup. Clean oil or fuel spillage. Allow machine to cool before storing.
- Stop and inspect the equipment if you strike an object. Repair, if necessary, before restarting.
- Never make adjustments or repairs with the engine running.
- Grass catcher components are subject to wear, damage, and deterioration, which could expose moving parts or allow objects to be thrown. Frequently check components and replace with manufacturer's recommended parts, when necessary.
- Mower blades are sharp and can cut. Wrap the blade(s) or wear gloves, and use extra caution when servicing them.
- Check brake operation frequently. Adjust and service as shown in the Operator's Manual.

# SAFETY



## SAFE OPERATION PRACTICES FOR RIDE-ON MOWERS



- **NEVER allow children to operate the machine.**
- Be sure the area is clear of other people before mowing. Stop machine if anyone enters the area.
- Never carry passengers or children even with the blades off.
- Do not drive in reverse unless absolutely necessary. Always look down and behind before and while backing.
- Never carry children. They may fall off and be seriously injured or interfere with safe machine operation.
- Keep children out of the mowing area and under the watchful care of another responsible adult.
- Be alert and turn machine off if children enter the area.
- Before and when backing, look behind and down for small children.
- Mow up and down slopes (10° Max), not across.
- Remove obstacles such as rocks, tree limbs, etc.
- Watch for holes, ruts, or bumps. Uneven terrain could overturn the machine. Tall grass can hide obstacles.
- Use a slow speed while on slope or hill.
- Avoid starting or stopping on a slope. If tires lose traction, disengage the blades and proceed slowly straight down the slope.
- If machine stops while going uphill, disengage blades, shift into reverse and back down slowly.
- Do not turn on slopes unless necessary, and then, turn slowly and gradually downhill, if possible.



### CAUTION

**Look for this symbol to point out important safety precautions. It means CAUTION! BECOME ALERT! YOUR SAFETY IS INVOLVED.**



### CAUTION

**In order to prevent accidental starting when setting up, transporting, adjusting or making repairs, always disconnect spark plug wire and place wire where it cannot contact spark plug.**



### WARNING

**Engine exhaust, some of its constituents, and certain vehicle components contain or emit chemicals known to the State of California to cause cancer and birth defects or other reproductive harm.**



### WARNING

**Battery posts, terminals and related accessories contain lead and lead compounds, chemicals known to the State of California to cause cancer and birth defects or other reproductive harm. Wash hands after handling.**

## UNPACKING INSTRUCTIONS

- Remove all parts and packing materials from carton.
- Check carton contents against list. Be sure all parts are there.

## TOOLS REQUIRED

- Two ½" Wrench
- 9/16" Wrench
- 9/16" Socket wrench

## CONTAINER CONTENTS

- |                         |  |
|-------------------------|--|
| 3 - Soft bag containers | 2 - Weight brackets                          |
| 1 - Upper chute         | 4 - Bolts $\frac{3}{8}$ -16 x $3\frac{3}{4}$ |
| 1 - Lower chute         | 8 - Nuts $\frac{3}{8}$ -16, Nyloc            |
| 1 - Catcher mount       | 8 - Bolts $\frac{5}{16}$ -18 x 1             |
| 1 - Cover Assembly      | 4 - Bolts $\frac{3}{8}$ -16 x $3\frac{1}{2}$ |
| 2 - Weight plates       |  |

## PARTS IDENTIFICATION

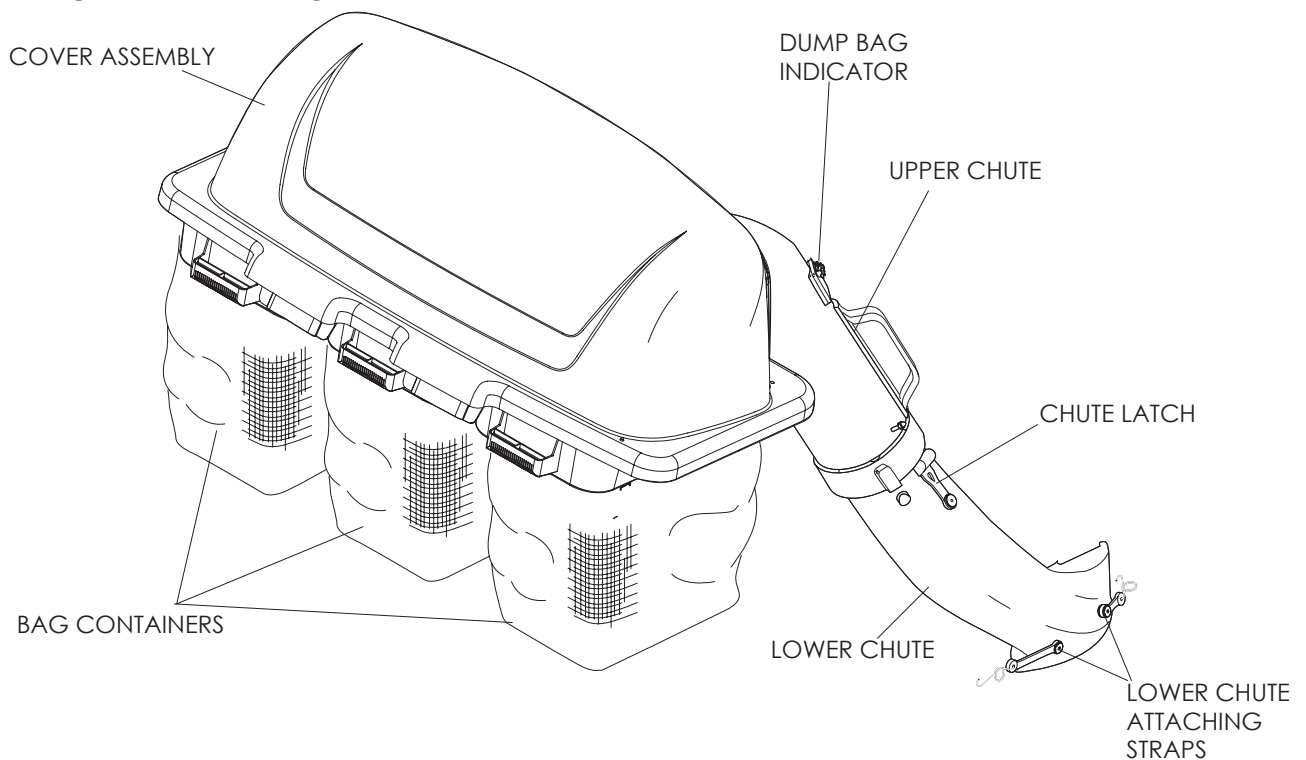

*NOTE: When right hand (RH) and left hand (LH.) are mentioned in this manual, it means when seated on the mower in the operator's position.*



### CAUTION

#### BEFORE ASSEMBLING GRASS CATCHER TO MOWER:

- Place motion control levers in "NEUTRAL" position.
- Set parking brake.
- Turn ignition key "OFF" and remove key.
- Make sure the blades and all moving parts have completely stopped.
- Disconnect spark plug and place wire where it cannot come in contact with plug.

# ASSEMBLY

## 1 BAGGER SUPPORT ASSEMBLY

1. Remove the four carriage bolts indicated from the rear guard.

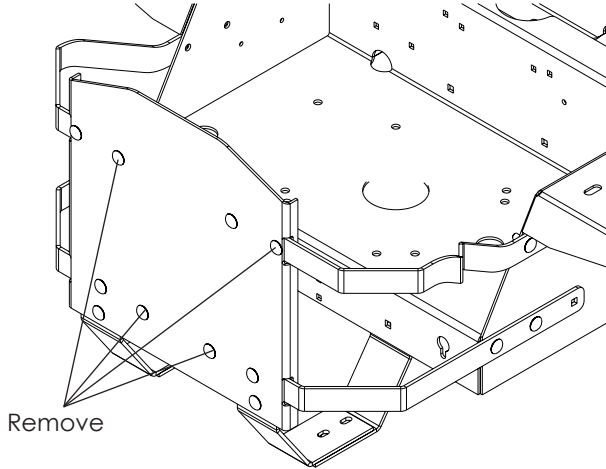

2. Install the bagger mount tube from the mount kit.
3. Remove the front carriage bolts securing the top mount straps to the frame.

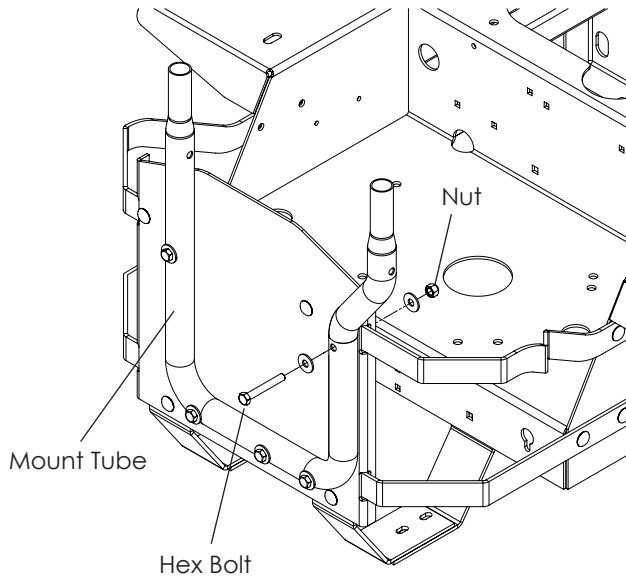

4. Install kit mount straps between the mount tube and frame as shown in the illustration. The front side of the kit mount straps should be on the inside of the mower frame.
- NOTE: Models with vertically mounted muffler will not use the right mount strap.*
3. Tighten all hardware.

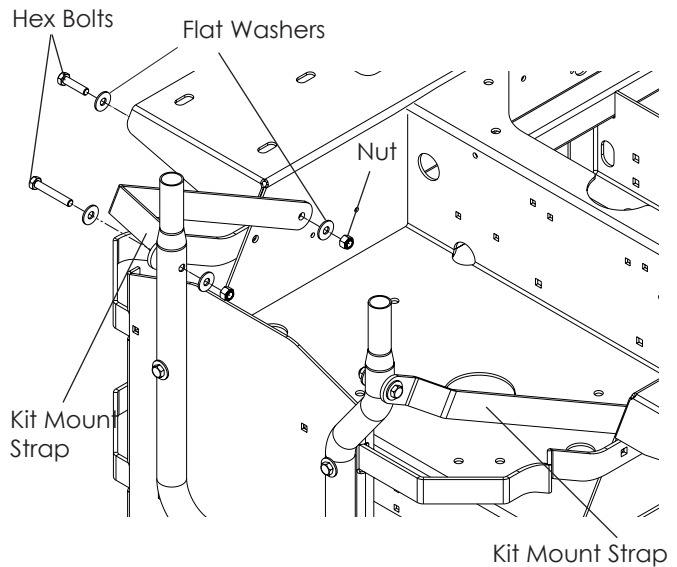



# ASSEMBLY

## 2 MOUNTING COVER ASSEMBLY TO SUPPORT ASSEMBLY

**NOTE:** For ease of assembly, you may wish to obtain the assistance of another person for mounting cover assembly to mower.

1. Position cover assembly on ground behind mower as shown.
2. Lift and rotate cover to align cover brackets with support assembly tubes.
3. Slide cover assembly down onto the support tubes.

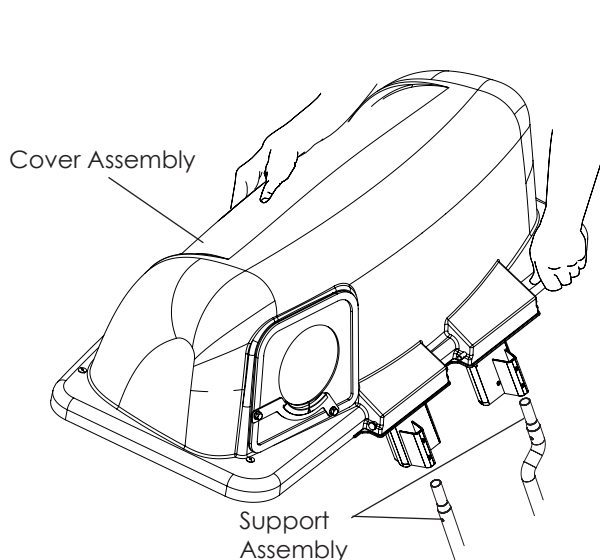

## 3 CONTAINER MOUNTING

1. Install containers on supports, overlapping at center supports.
2. Close cover and lock latch handles over center support tubes.

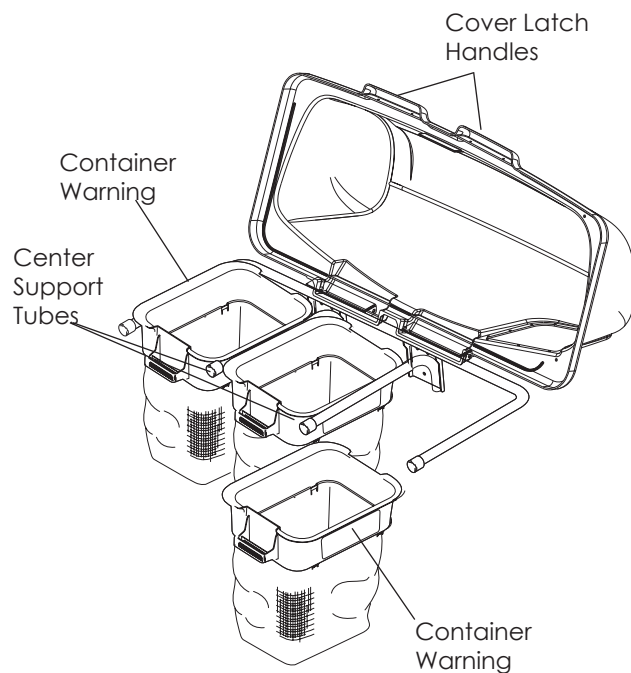

### WARNING!

**DO NOT** operate mower unless container is properly installed. Container is subject to wear and deterioration, check containers frequently, replace when cracked or damaged. Use only a recommended replacement container.

# ASSEMBLY

## 4 LOWER CHUTE

1. Turn mower engine off.
2. Raise and hold deflector shield in upright position.
3. Place slot in lower chute over tab on mower deck and position lower chute over deck opening as shown.
4. Hook rear latch into flange hole on back of mower deck.
5. Hook front latch into tab hole on front of mower deck.



### CAUTION

Before raising deflector shield, turn mower engine off. DO NOT remove deflector shield from mower. Raise and hold shield when attaching lower chute and allow it to rest on chute while in operation.

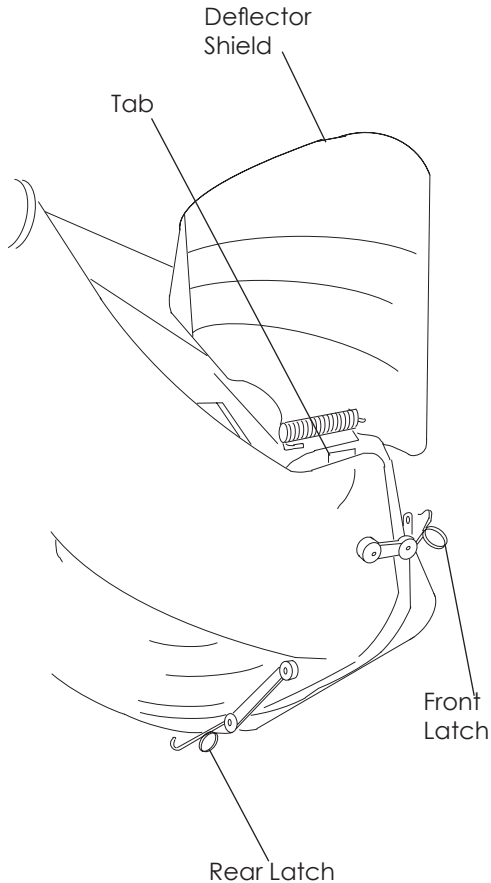

## 5 UPPER CHUTE

1. Lower mower deck to its lowest cutting position.
  2. Assemble upper chute by inserting curved end into hole in back of cover.
- NOTE:** Handle carefully so as not to damage dump bag indicator.
3. Push in and turn upper chute until it is in line with lower chute.
  4. Align the bosses on lower chute with alignment slots on upper chute with alignment slots on upper chute and slide together.
  5. Secure with rubber latch by hooking hole in latch over latch pin.

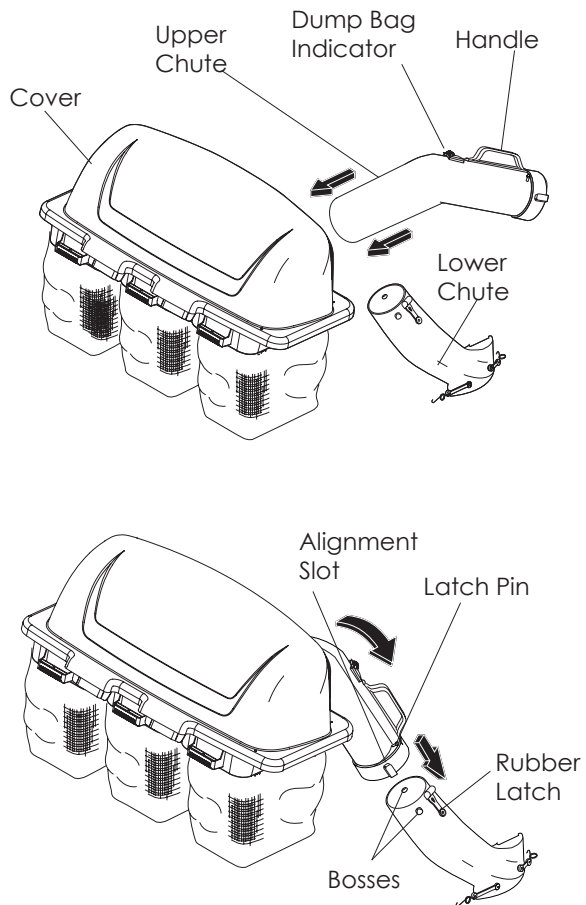

## 6 LEVEL MOWER DECK

Be sure deck is properly leveled for best mower performance. See your mower operator's manual for instructions.

# ASSEMBLY

## 7 FRONT WEIGHT

1. Bolt cast weight to brackets using four (4) 2 $\frac{3}{4}$ " bolts and nuts.
2. Slide weight brackets over front tube, centering weights on frame.
3. Secure with four (4) 2 $\frac{3}{4}$ " bolts and nuts.



**CAUTION**

**DO NOT operate mower with grass catcher unless the front weights are installed.**

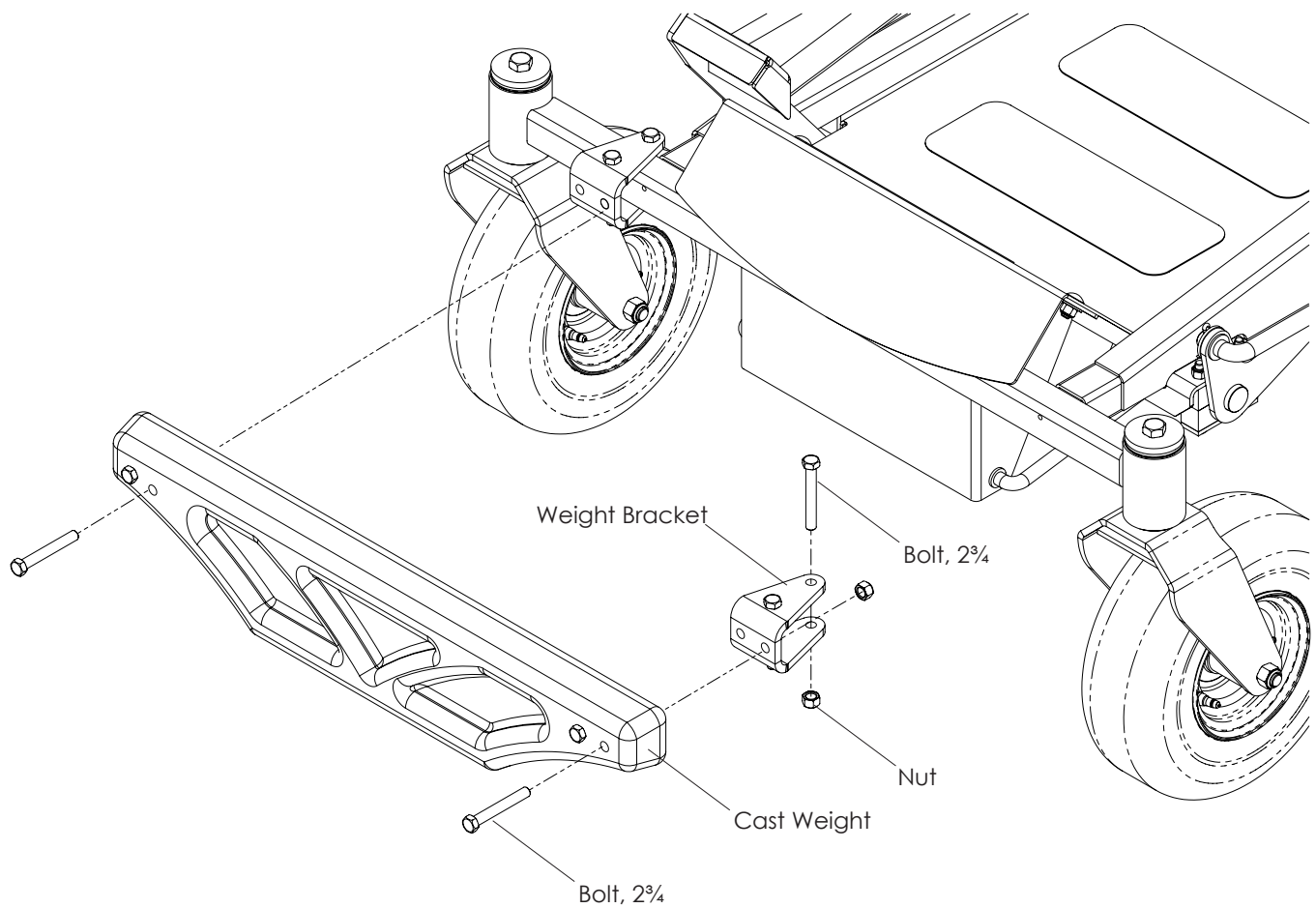

# OPERATION

## TIPS FOR IMPROVED BAGGING OPERATION

Follow the mower operation instructions in the mower operator's manual.

When utilizing the grass catcher on a lawn where grass and leaf bagging equipment has not been used, thatch and debris that has accumulated for long periods of time will be picked up. The amount collected and the total time of operation may be greater than experienced with regular use of the grass catcher.

- Always run throttle at full speed when bagging.
- Select a speed low enough to give good mower cutting performance, good quality cut and good bagging performance.  
*NOTE: It may be necessary to overlap width of cut to suit your conditions.*
- If grass is extremely tall, it should be mowed twice. The first time relatively high, the second time to desired height.
- Use left hand side of mower for trimming.
- Plastic trash bags (3.0 mil, 30 gallon) can be inserted inside grass catcher containers for ease of debris disposal. To remove the plastic trash bags when full:
  - a. Disengage blades, shift into neutral, engage the parking brake and stop the engine.
  - b. Unlatch and raise cover.
  - c. Remove one container at a time by grasping container handles and pulling toward the rear, off of the tube rails.
  - d. With the container resting on the ground, close and secure the top of the plastic lawn bag.
  - e. Tip the container on its side and slide the filled bag from the container.
  - f. Install a new plastic lawn bag with the edges of the bag draped over upper lip of the container.
  - g. Repeat for other container.
  - h. Reinstall containers making sure containers overlap left at center supports.
  - i. Close cover and secure latches over center support tubes.
- Avoid cutting wet grass or mowing in the morning while the dew is still heavy. Grass clippings collected under these conditions tend to be sticky and adhere to the walls of the flow path causing clogging.
- If the grass catcher fails to pick up cut grass

or leaves, it is an indication that clogging has occurred in the system or that the grass catcher containers are full.

- a. Disengage blades, place motion control levers in neutral position.
  - Unlatch and raise cover.
  - Slide out containers and dispose of clippings.
  - Replace containers, close cover, and latch.
- b. Unlatch chutes and check for clogging.
  - Remove all debris in chute.
  - Reassemble and latch chutes.



### CAUTION

- **DO NOT operate mower with grass catcher partially installed.**
- **Disengage blades and stop engine before leaving mower seat to empty containers, unclogging chutes, etc.**
- **Close cover before starting.**
- **Disengage mower blades when crossing driveways or gravel surfaces and other areas where thrown objects could be a hazard.**
- **DO NOT attempt to vacuum up cans or other potentially hazardous projectiles.**

# CUSTOMER RESPONSIBILITIES

---

## GENERAL RECOMMENDATIONS

Always observe safety rules when performing any maintenance.

- Before each use check for loose fasteners.
- Clean unit thoroughly after each use.

## BLADE CARE

For best results mower blades must be kept sharp.  
Replace bent or damaged blades.

- See BLADE CARE instructions in your mower operator's manual.

## STORAGE

When grass catcher is to be stored for a period of time, clean it thoroughly, remove all dirt, grass, leaves, etc. Store in a clean, dry place.



### CAUTION

**BEFORE PERFORMING MAINTENANCE,  
SERVICE OR ADJUSTMENTS:**

- Place motion control levers in "NEUTRAL" position.
- Set parking brake.
- Place clutch control in "DISENGAGED" position.
- Turn ignition key to "OFF" position.
- Make sure blades and all moving parts have completely stopped.
- Disconnect spark plug wire(s) from spark plug(s) and place wire where it cannot come in contact with plug.



### CAUTION

**Do not leave grass in bagger containers. Empty containers after each use and before storing. Failure to do so may result in spontaneous combustion which could develop into a fire.**



### CAUTION

**Grass catcher components are subject to wear, damage and deterioration, which could expose moving parts or allow objects to be thrown. Frequently check components and replace with manufacturer's recommended parts when necessary.**

# PARTS

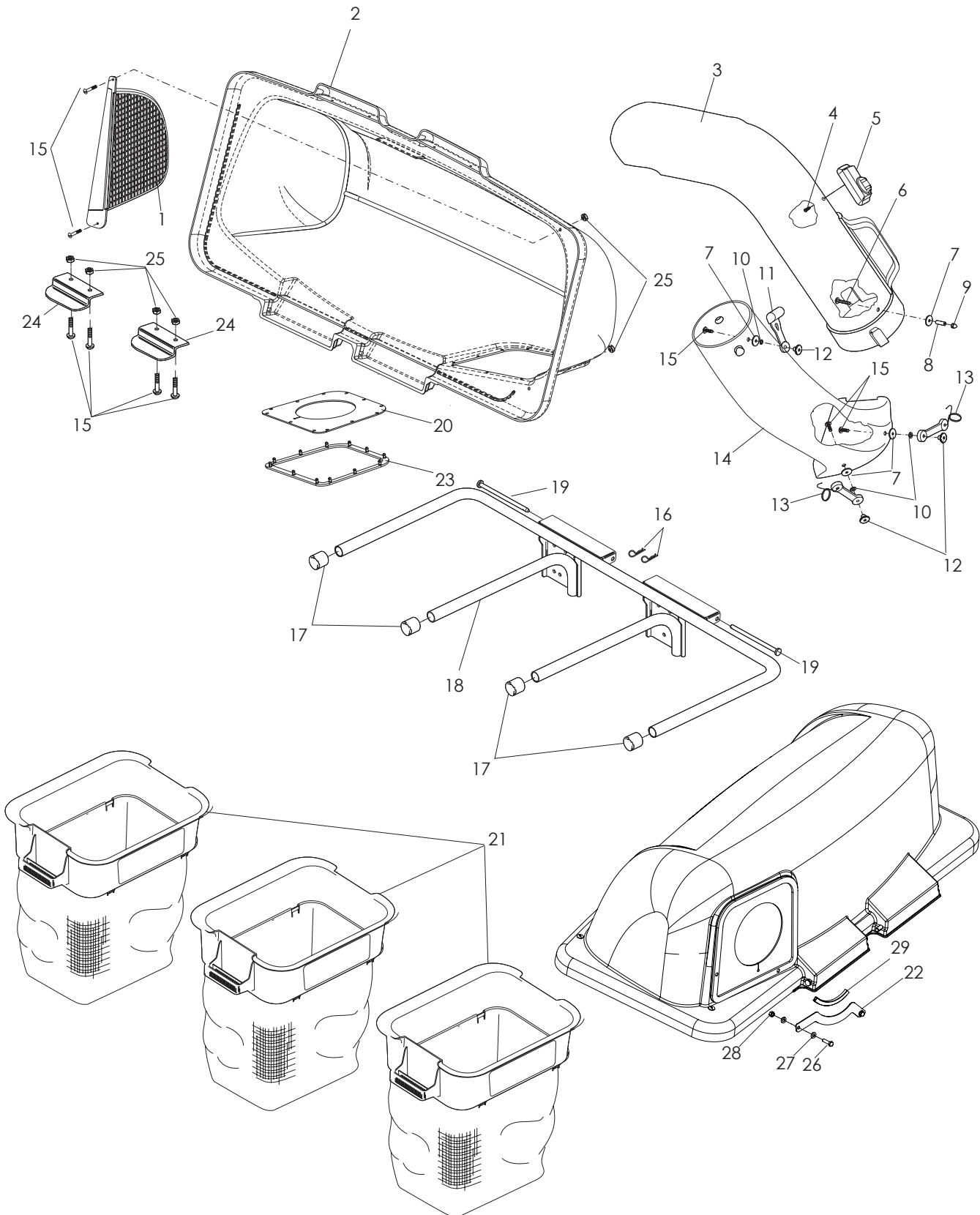

# PARTS

---

ITEM	PART NO.	QTY.	DESCRIPTION	ITEM	PART NO.	QTY.	DESCRIPTION
1..	532 192709....	1	SCREEN, COVER	18..	539 108098....	1	BAGGER, FRAME
2..	532 195373....	1	COVER	19..	532 192786....	2	PIN, HINGE
3..	539 108141....	1	CHUTE, UPPER	20..	532 192550....	1	SEAL, COVER
4..	539 108081....	1	SCREW #10-14 x 1/2 SPEC	21..	532 400226....	3	CONTAINER, SOFT BAG
5..	539 108082....	1	DUMP BAG INDICATOR	22..	539 110234....	1	SUPPORT, CHUTE
6..	539 108083....	1	SCREW #10-24 x 1 1/8	23..	532 192603....	1	GASKET, COVER
7..	539 108084....	4	WASHER 3/16 x 3/4 x 16 GA	24..	532 130895....	2	HANDLE, BAGGER COVER
8..	539 108085....	1	SPACER, SPLIT	25..	539 976977..	14	NUT #10-24 CROWNLOCK
9..	539 108086....	1	NUT #10-24 ACORN	26..	539 990627....	2	HCS 5/16-18 x 1 1/4
10..	539 109552....	3	LOCKWASHER 3/16	27..	539 990188....	4	WASHER 5/16 SAE FLT
11..	539 108088....	2	LATCH, CHUTE	28..	539 990717....	2	NUT 5/16-18 HEX NYLOC
12..	539 108089....	6	NUT, WELD	29..	539 112294....	1	FLEX TRIM
13..	539 108194....	4	LATCH, ASSEMBLY	NOT SHOWN			
14..	539 405455....	1	CHUTE, LOWER 46" DECK	539 108447 ...	1	DECAL, CE	
15..	539 976952....	6	SCREW #10-24 x 5/8	539 108163 ...	1	DECAL, CATCHER	
16..	539 108096....	2	HAIR PIN				
17..	539 108097....	4	PLUG, TUBING END				

NOTE: ALL FASTENERS ARE GRADE 5 UNLESS OTHERWISE SPECIFIED.

# PARTS

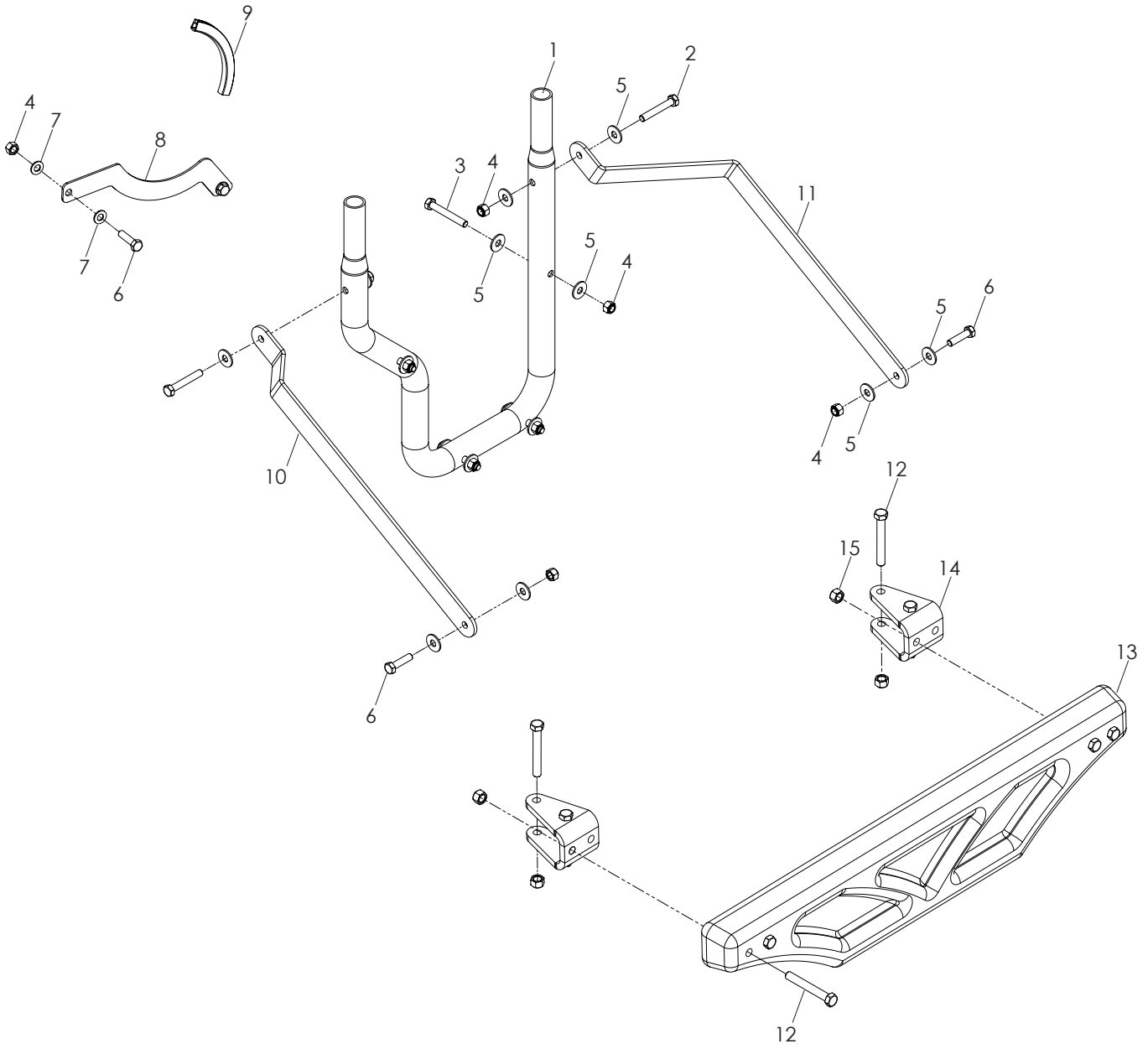



# PARTS

---

ITEM	PART NO.	QTY.	DESCRIPTION	ITEM	PART NO.	QTY.	DESCRIPTION
1..	539 131091	...1	.... TUBE, MOUNT	9..	539 112294	...1	.... FLEX TRIM
2..	539 976937	...2	.... HCS $\frac{5}{16}$ -18 x 2	10..	539 131089	...1	.... STRAP, RT
3..	539 976938	...4	.... HCS $\frac{5}{16}$ -18 x 2 $\frac{1}{4}$	11..	539 131090	...1	.... STRAP, LT
4..	539 990717	.10	.... NUT $\frac{5}{16}$ -18 HEX NYLOC	12..	539 102612	...8	.... HCS $\frac{3}{8}$ -16 x 2 $\frac{3}{4}$
5..	539 990692	.16	.... WASHER $\frac{5}{16}$ STD FLT	13..	539 111587	....1	.... CAST WEIGHT
6..	539 990627	...4	.... HCS $\frac{5}{16}$ -18 x 1 $\frac{1}{4}$	14..	539 113203	...2	.... BRACKET, WEIGHT
7..	539 990188	...4	.... WASHER $\frac{5}{16}$ SAE FLT	15..	539 976979	...8	.... NUT $\frac{3}{8}$ -16 HEX NYLOC
8..	539 110234	...1	.... SUPPORT, CHUTE				

NOTE: ALL FASTENERS ARE GRADE 5 UNLESS OTHERWISE SPECIFIED.

# TORQUE CHART

## TORQUE SPECIFICATIONS HEX HEAD CAP SCREWS

The torque values shown should be used as a general guideline when specific torque values are not given.

### U.S. Standard Hardware

Grade	SAE grade 5		SAE grade 8		Flangelock Screw w/ Flangelock Nut		
	ft./lbs	Nm	ft./lbs	Nm	ft./lbs	Nm	
Shank Size (Diameter in inches, fine or coarse thread)	1/4	9	12	13	18		
	5/16	18	24	28	38	24	33
	3/8	31	42	46	62	40	54
	7/16	50	68	75	108		
	1/2	75	102	115	156		
	9/16	110	150	165	224		
	5/8	150	203	225	305		
	3/4	250	339	370	502		
	7/8	378	513	591	801		
	1	583	790	893	1211		
	1 1/8	782	1060	1410	1912		

\*\* Grade 5 - Minimum commercial quality (Lower quality not recommended)

### Metric Standard Hardware

Grade	Grade 8.8 8.8		Grade 10.9 10.9		Grade 12.9 12.9		
	ft./lbs	Nm	ft./lbs	Nm	ft./lbs	Nm	
Shank Size (Diameter in millimeters, fine or coarse thread)	M4	1.5	2	2.2	3	2.7	3.6
	M5	3	4	4.5	6	5.2	7
	M6	5.2	7	7.5	10	8.2	11
	M7	8.2	11	12	16	15	20
	M8	13.5	18	18.8	25	21.8	29
	M10	24	32	35.2	47	43.5	58
	M12	43.5	58	62.2	83	75	100
	M14	70.5	94	100	133	119	159
	M16	108	144	147	196	176	235
	M18	142	190	202	269	242	323
	M20	195	260	275	366	330	440
	M22	276	368	390	520	471	628
	M24	353	470	498	664	596	794
	M27	530	707	474	996	904	1205



