

Operator's manual

ZTH

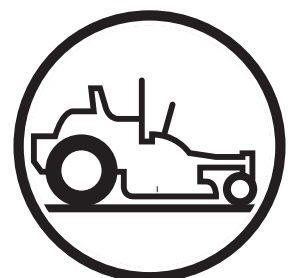

Please read these instructions carefully and make sure you understand them before using the machine.

English

OPERATOR'S MANUAL

RIDER

ZTH

Contents

Contents	1	Checking the Engine's Cooling Air Intake	29
Introduction	3	Checking and Adjusting the Choke Cable	29
Congratulations	3	Replacing the Air Filter	30
General	3	Replacing the Fuel Filter	31
Driving and Transport on Public Roads	3	Checking the Fuel Pump's Air Filter	31
Towing	3	Checking Tire Pressures	31
Operating	3	Checking the Parking Brake	32
Good Service	4	Checking the Blades	32
Manufacturing Number	4	Adjusting the Mower Deck	32
Symbols and Decals	5	Cleaning and Washing	32
Safety Instructions	6	Lubrication	33
General Use	6	Lubrication Schedule	33
Driving on Slopes	8	General	33
Children	9	Lubricating the Cables	34
Maintenance	9	Lubricating in Accordance with the Lubrication Schedule	34
Transport	11	Trouble Shooting Guide	40
Presentation	12	Storage	43
Control Locations	12	Winter Storage	43
Choke Control	13	Service	43
Throttle Control	13	Technical Data	44
Ignition Lock	13	Meas., Weights, Etc. ZTH5223 ZTH6125	44
Hour Meter	13	Engine	44
Engaging the Mower Deck	14	Noise Emissions and Cutting Width	45
Parking Brake	14	Electrical System	45
Seat Locking Device	14	Transmission	45
Adjusting the Seat	15	Mower Deck	45
Steering Controls	15	Accessories	45
Refueling	16	Service Journal	46
Fuel Tap	16	Delivery Service	46
Fuses	16	After the First 8 Hours	47
Lifting Lever for the Mower Deck	17	25-Hour Service	48
Accessories	17	50-Hour Service	49
Running	18	100-Hour Service	50
Before Starting	18	300-Hour Service	51
Starting the Engine	18	At Least Once Each Year	52
Running	21		
Mowing Tips	23		
Stopping the Engine	24		
Moving by Hand	24		
Maintenance	25		
Maintenance Schedule	25		
Ignition System	27		
Checking the Safety System	27		

INTRODUCTION

Introduction

Congratulations

Thank you for purchasing a Husqvarna ride-on mower. This machine is built for the greatest efficiency and rapid mowing primarily of large areas. Controls in one place and a hydrostatic transmission regulated by steering controls also contribute to the machine's performance.

This manual is a valuable document. Following the instructions (use, service, maintenance, etc.) can considerably increase the lifespan of your machine and even increase its resale value.

If you sell your machine, be sure to give the operator's manual to the new owner.

The final chapter of this operator's manual comprises a Service Journal. Ensure that service and repair work is documented. A well kept service journal reduces service costs for the season-based maintenance and affects the machine's resale value. Take the operator's manual along when the machine is left to the workshop for service.

General

In this operator's manual, left and right, backward and forward are used in relation to the machine's normal driving direction.

Driving and Transport on Public Roads

Check applicable road traffic regulations before driving and transport on public roads. If the machine is transported, you shall always use approved fastening equipment and ensure that the machine is well anchored.

Towing

When your machine is equipped with a hydrostatic transmission you should, if necessary, only tow the machine over short distances and at a low speed, otherwise there is a risk of damaging the transmission.

Operating

This machine is constructed only for mowing grass on lawns and other free and even ground without obstacles such as stones, tree stumps, etc. The machine can also be used for other tasks when equipped with special accessories provided by the manufacturer, for which the operating instructions are provided in conjunction with delivery. All other types of use are incorrect. The manufacturer's directions concerning operation, maintenance, and repairs must be carefully followed.

The machine must only be operated, maintained, and repaired by persons that are familiar with the machine's special characteristics and who are well versed in the safety instructions.

Accident prevention regulations, other general safety regulations, occupational safety rules, and traffic regulations must be followed without fail.

Unauthorized modifications to the design of the machine may absolve the manufacturer from liability for any resulting personal injury or property damage.

INTRODUCTION

Good Service

Husqvarna's products are sold all over the world and only in specialized retail trade with complete service. This ensures that you as a customer receive only the best support and service. Before the product is delivered, the machine has, for example, been inspected and adjusted by your retailer, see the certificate in the Service Journal in this operator's manual.

When you need spare parts or support in service questions, guarantee issues, etc., please consult the following professional:

This Operator's Manual belongs to the machine with manufacturing number:	Engine	Transmission

Manufacturing Number

The machine's manufacturing number can be found on the printed plate affixed behind the battery under the seat. Stated on the plate, from the top are:

- The machine's type designation (I.D.).
- The manufacturer's type number (Model).
- The machine's serial number (Serial no.)

Please state the type designation and serial number when ordering spare parts.

The engine's manufacturing number is stated on a barcode decal. This is placed on the left side of the crankcase, in front of the start motor. The plate states:

- The engine's serial number (E/NO).
- The engine's type designation (Code).

Please state these when ordering spare parts.

The hydraulic pump's manufacturing number is stated on a barcode decal affixed to the left side of the pump housing. The plate states:

- The pump's type designation.
- The pump's serial number.

The hydraulic motor's manufacturing number is stated on a round metal plate. This is placed on the gable inside the motor. The plate states:

- The hydraulic motor's type designation and design version.
- The hydraulic motor's serial number.

SYMBOLS AND DECALS

Symbols and Decals

These symbols are found on the machine and in the operator's manual. Study them carefully so that you know what they mean.

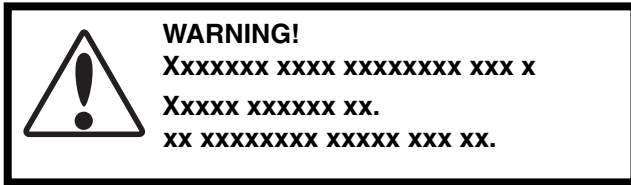

Used in this publication to notify the reader of a risk of **personal injury**, particularly if the reader should neglect to follow instructions given in the manual.

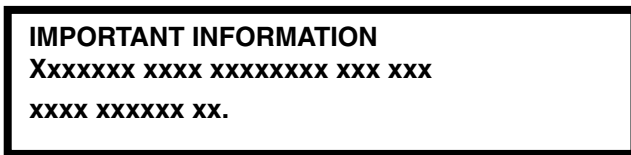

Used in this publication to notify the reader of a risk of **material damage**, particularly if the reader should neglect to follow instructions given in the manual. Used also when there is a potential for misuse or misassembly.



Reverse



Neutral



Fast



Slow



Choke



Fuel



Warning!



Parking brake



CE conformity marking



Warning! Rotating blades, keep away from the discharge deck

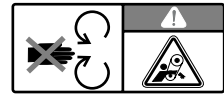

Do not touch rotating parts



Battery acid is corrosive, explosive, and flammable

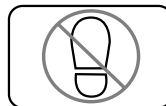

Do not stand here



Noise emissions to the surroundings in accordance with the European Union's directive. The machine's emission is stated in the chapter TECHNICAL DATA and on the decals.

SAFETY INSTRUCTIONS

Safety Instructions

These instructions are for your safety. Read them carefully.



WARNING!

This symbol means that important safety instructions need to be emphasized. It concerns your safety.

General Use

- Read all instructions in this operator's manual and on the machine before starting it. Ensure that you understand them and then abide by them.
- Learn how to use the machine and its controls safely and learn how to stop quickly. Also learn to recognize the safety decals.
- Only allow the machine to be used by adults who are familiar with its use.
- Make sure nobody else is in the vicinity of the machine when you start the engine, engage the drive, or run the machine.
- Make sure animals and people maintain a safe distance from the machine.
- Stop the machine if someone enters the work area.
- Clear the area of objects such as stones, toys, steel wire, etc. that may become caught in the blades and thrown out.
- Beware of the discharge deck and do not point it at any one. Do not use the machine without the discharge deck in place.
- Stop the engine and prevent it from starting before you clean the discharge deck.
- Remember that the operator is responsible for dangers or accidents.
- Never take passengers. The machine is only intended for use by one person.
- Always look down and behind before and during reversing maneuvers. Keep a look out for both large and small obstacles.
- Slow down before turning.
- Shut down the blades when not mowing.

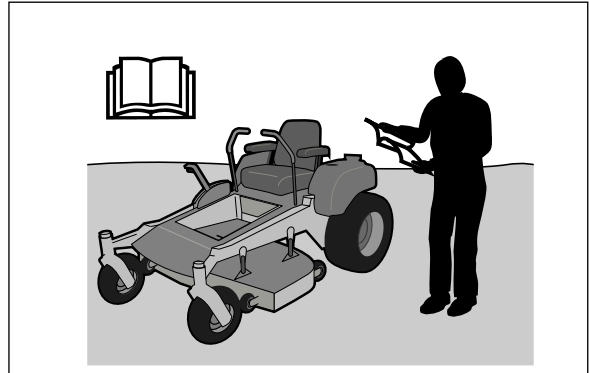

8011-512

Read the operator's manual before starting the machine

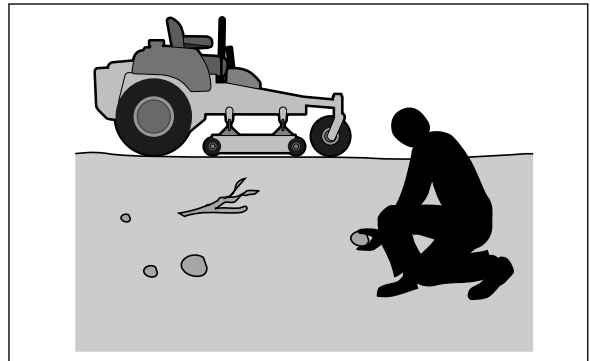

8011-513

Clear the area of objects before mowing



8011-520

Never take passengers

SAFETY INSTRUCTIONS

- Be careful when rounding fixed objects, so that the blades do not hit them. Never drive over foreign objects.
- Only use the machine in daylight or in other well-lit conditions. Keep the machine a safe distance from holes or other irregularities in the ground. Pay attention to other possible risks.
- Never use the machine if you are tired, if you have consumed alcohol, or if you are taking other drugs or medication that can affect your vision, judgment, or coordination.
- Beware of traffic when working near or crossing a road.
- Never leave the machine unsupervised with the engine running. Always shut down the blades, pull back the parking brake, stop the engine, and remove the ignition key before leaving the machine.
- Never allow children or other persons not trained in the use of the machine to use or service it. Local laws may regulate the age of the user.
-



WARNING!
Engine exhaust and certain vehicle components contain or emit chemicals considered to cause cancer, birth defects, or other reproductive system damage. The engine exhaust contains carbon monoxide, which is a colorless, poisonous gas. Do not use the machine in enclosed spaces.



8011-518

Keep children away from the work area



WARNING!
When using the machine, approved personal protective equipment shall be used. Personal protective equipment cannot eliminate the risk of injury but it will reduce the degree of injury if an accident does happen. Ask your retailer for help in choosing the right equipment.

- Make sure that you have first aid equipment close at hand when using the machine.
- Never use the machine when barefoot. Always wear protective shoes or boots, preferably with steel toecaps.
- Always wear approved protective glasses or a full visor when assembling or driving.
- Never wear loose clothing that can fasten in moving parts.

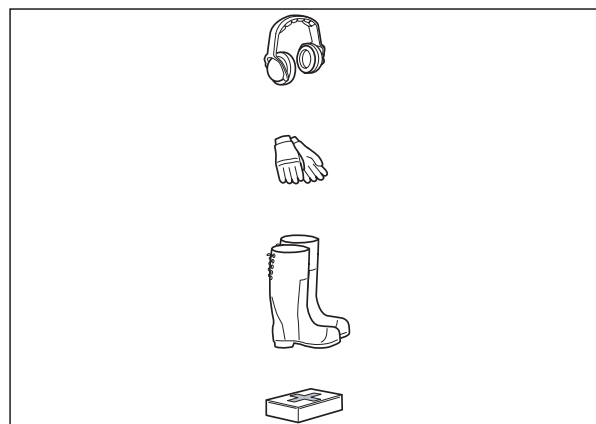

8011-292

Personal protective equipment

SAFETY INSTRUCTIONS

Driving on Slopes

Driving on slopes is one of the operations where the risk is greatest that the driver will lose control or the machine will tip over, which can result in serious injury or death. All slopes require extra caution. If you cannot reverse up a slope or if you feel unsure, do not mow the slope.

Do as follows

- Remove obstacles such as stones, tree branches, etc.
- Mow up and down, not side-to-side.
- Never drive the rider on terrain that slopes more than 15°.
- Avoid starting or stopping on a slope. If the tires begin to slip, shut down the blades and drive slowly down the slope.
- Always drive evenly and slowly on slopes.
- Make no sudden changes in speed or direction.
- Avoid unnecessary turns on slopes, and if it proves necessary, turn slowly and gradually downward, if possible.
- Watch out for and avoid driving over furrows, holes, and bumps. On uneven terrain, the machine can tip more easily. Long grass can hide obstacles.
- Drive slowly. Use small movements of the steering controls.
- Be extra cautious with any additional equipment, which can alter the machine's stability.
- Do not mow near verges, ditches, or banks. The machine can suddenly spin around if a wheel goes over the edge of a drop or ditch, or if an edge gives way.
- Do not mow wet grass. It is slippery, and the tires can lose their grip, so that the machine slides.
- Try not to stabilize the machine by putting a foot on the ground.
- When cleaning the chassis, the machine may never be driven near verges or ditches.

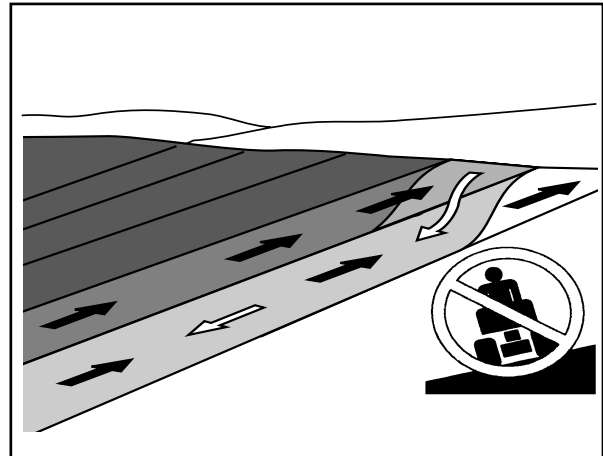

6003-004

Mow up and down, not side-to-side



8011-519

Be extra cautious when driving on slopes

SAFETY INSTRUCTIONS

Children

- Serious accidents may occur if you fail to be on guard for children in the vicinity of the machine. Children are often attracted to the machine and mowing work. Never assume that children will stay put where you last saw them.
- Keep children away from the mowing area and under close supervision by another adult.
- Keep an eye out and shut off the machine if children enter the work area.
- Before and during a reversing maneuver, look backward and downward for small children.
- Never allow a child to ride with you. They can fall off and injure themselves seriously or prevent risk-free maneuvering of the machine.
- Never allow children to operate the machine.
- Be particularly cautious near corners, bushes, trees, or other objects that block your view.

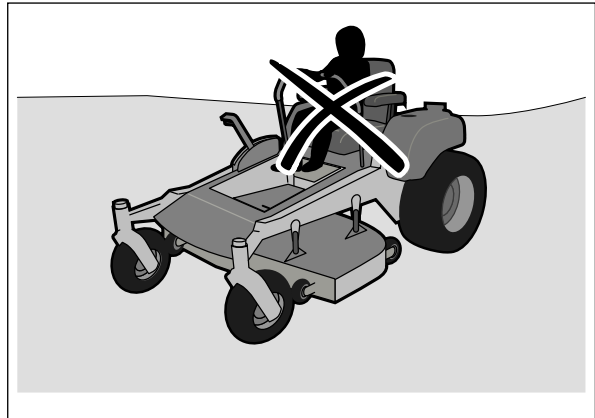

8011-517

Never allow children to operate the machine

Maintenance



WARNING!

The engine must not be started when the driver's floor plate or any protective plate for the mower deck's drive belt is removed.

- Stop the engine. Prevent the engine from starting by removing the spark plug cables from the spark plugs or by removing the ignition key before making any adjustments or performing maintenance.
- Never fill the fuel tank indoors.
- Gasoline and gasoline fumes are poisonous and extremely flammable. Be especially cautious when handling gasoline, as carelessness can result in personal injury or fire.
- Only store fuel in containers approved for the purpose.
- Never remove the fuel tank cap and never fill the fuel tank while the engine is running.

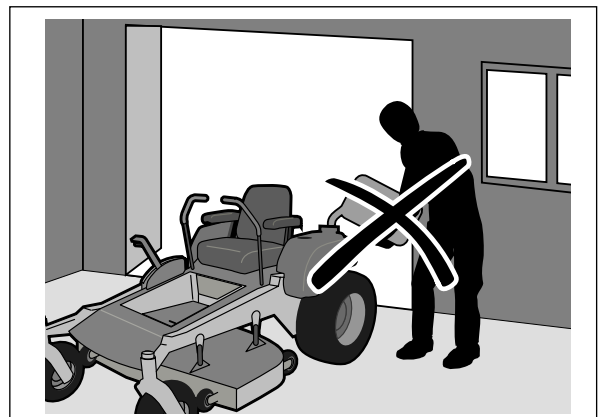

8011-516

Never fill the fuel tank indoors

SAFETY INSTRUCTIONS

- Allow the engine to cool before refueling. Do not smoke. Do not fill fuel in the vicinity of sparks or open flames.
- If leaks arise in the fuel system, the engine must not be started until the problem has been resolved.
- Store the machine and fuel in such a way that there is no risk of leaking fuel or fuel vapor leading to damages.
- Check the fuel level before each use and leave space for the fuel to expand, because the heat from the engine and the sun may otherwise cause the fuel to expand and overflow.
- Avoid overfilling. If you spill gasoline on the machine, wipe up the spill and wait until it has evaporated before starting the engine. If you have spilled gasoline on your clothing, change your clothing.
- Allow the machine to cool before taking any actions in the engine room.
- Be very careful when handling battery acid. Acid on skin can cause serious corrosive burns. If you spill battery acid on your skin, rinse immediately with water.
- Acid in the eyes can cause blindness, contact a doctor immediately.
- Be careful when servicing the battery. Explosive gases form in the battery. Never perform maintenance on the battery when smoking or near open flames or sparks. The battery can explode and cause serious injury/damage.
- Ensure that nuts and bolts, especially the fastening bolts for the blade attachments, are properly tightened and that the equipment is in good condition.
- Do not modify safety equipment. Check regularly to be sure it works properly. The machine must not be driven with defective or unmounted protective plates, protective cowlings, safety switches, or other protective devices.
- Do not change the settings of governors and avoid running the engine with overly high engine speeds. If you run the engine too fast, you risk damaging the machine components.

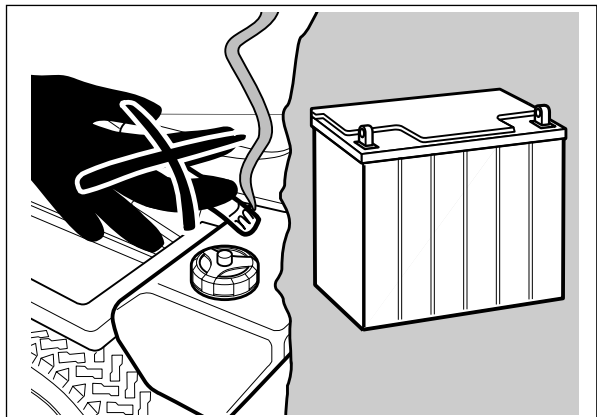
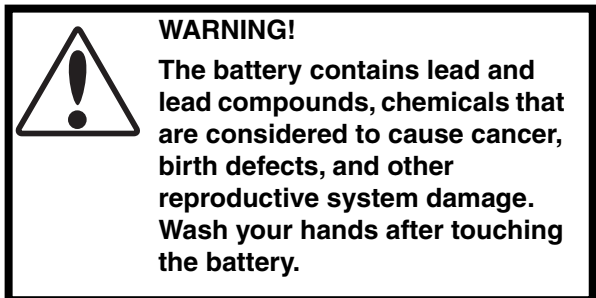
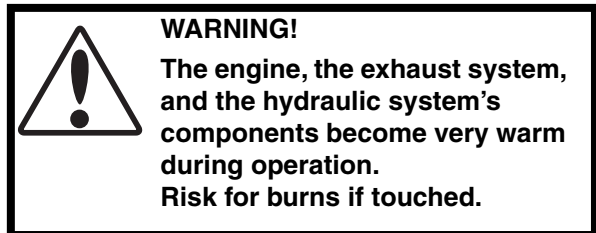

6003-009

Do not smoke when performing maintenance on the battery. The battery can explode and cause serious injury/damage

SAFETY INSTRUCTIONS

- Never use the machine indoors or in spaces lacking proper ventilation. The exhaust fumes contain carbon monoxide, an odorless, poisonous, and lethal gas.
- Stop and inspect the equipment if you run over or into anything. If necessary, make repairs before starting.
- Never make adjustments with the engine running.
- The machine is tested and approved only with the equipment originally provided or recommended by the manufacturer.
- The blades are sharp and can cause cuts and gashes. Wrap the blades or use protective gloves when handling them.
- Check the parking brake's functionality regularly. Adjust and service as necessary.
- The BioClip deck shall only be used when higher quality mowing is desired in familiar areas.
- Reduce the risk of fire by removing grass, leaves, and other debris that may have fastened in the machine. Allow the machine to cool before putting it in storage.

Transport

- The machine is heavy and can cause serious crushing injuries. Be extra cautious when it is loaded on or unloaded from a vehicle or trailer.
- Use an approved trailer to transport the machine. Activate the parking brake, turn off the fuel supply, and fasten the machine with approved fastening devices, such as bands, chains, or ropes, when transporting.
- Check and abide by local traffic regulations before transporting or driving the machine on any road.

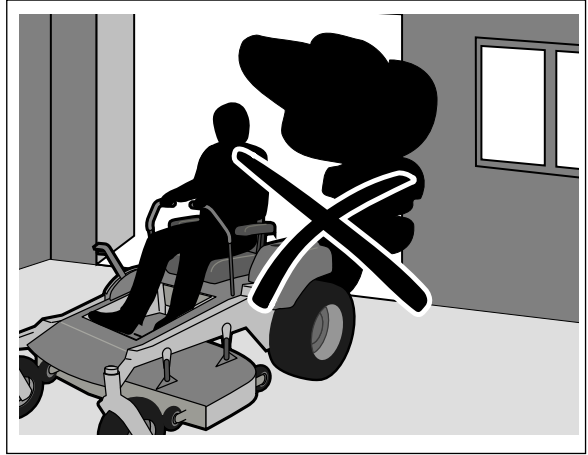

8011-515

Never drive the machine in an enclosed space

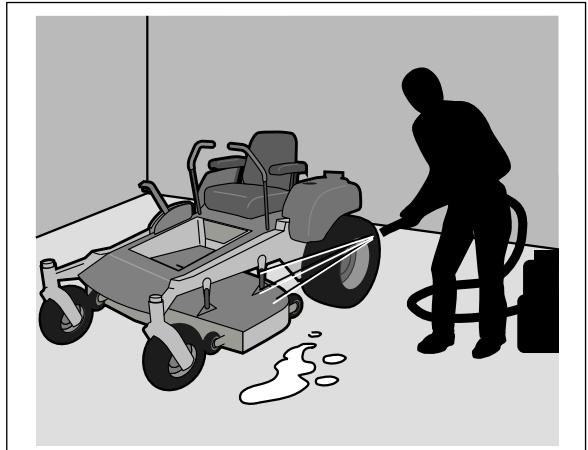

8011-514

Clean the machine regularly

IMPORTANT INFORMATION

The parking brake is not sufficient to lock the machine in place during transport. Ensure that the machine is well fastened to the transport vehicle. Reverse the machine onto the transport vehicle to avoid tipping it over.

PRESENTATION

Presentation

This operator's manual describes the Husqvarna Lever-Steered Rider. The rider is fitted with a Kawasaki four-stroke V-Twin engine developing 23/25 horse power.

Transmission from the engine is made via two belt-driven hydraulic pumps, which in turn drive a hydraulic motor for each drive wheel. Using the left and right steering controls, the flow is regulated and thereby the direction and speed.

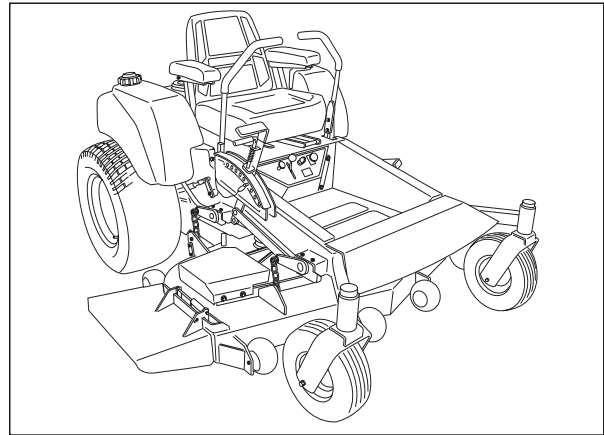

8011-583

Lever-Steered Rider

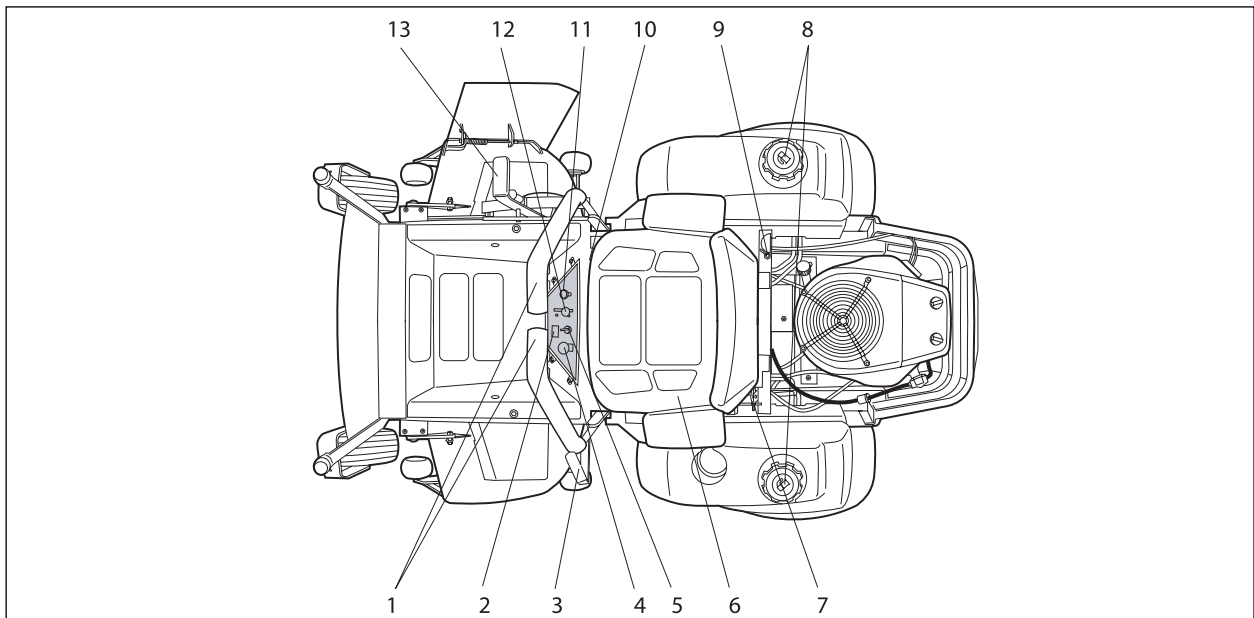

8011-602

Locations of the controls

Control Locations

- | | |
|--|---|
| 1. Steering control, left and right | 8. Fuel tank cap |
| 2. Hour meter | 9. Fuel tap |
| 3. Parking brake | 10. Seat adjustment lever |
| 4. Control for engaging the mower deck | 11. Choke control |
| 5. Ignition lock | 12. Throttle - regulates the engine speed |
| 6. Fuses | 13. Cutting height adjuster |
| 7. Seat lock lever | |

PRESENTATION

Choke Control

The choke control is used for cold starts in order to provide the engine with a richer fuel mixture.

For cold starts the control shall be pulled out.

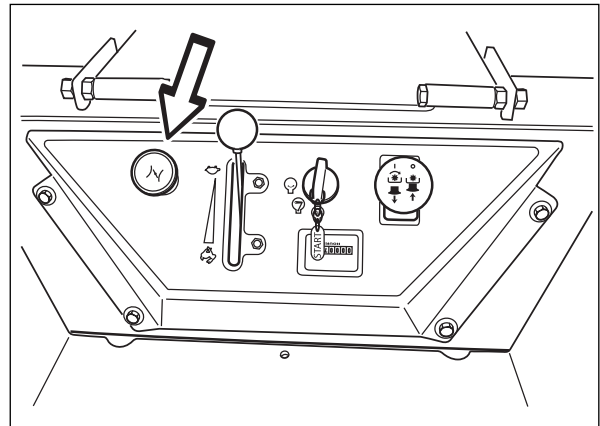

8011-508

Choke control

Throttle Control

The throttle control regulates the engine speed and thereby even the rate of rotation of the blades, assuming the control for engaging the mower deck is pulled out, see Engaging the Mower Deck.

In order to increase or decrease the engine speed, the control is moved downward or upward respectively.

Avoid idling the engine for longer periods, as there is a risk of the spark plugs gaining a coating.

Use full throttle when mowing.

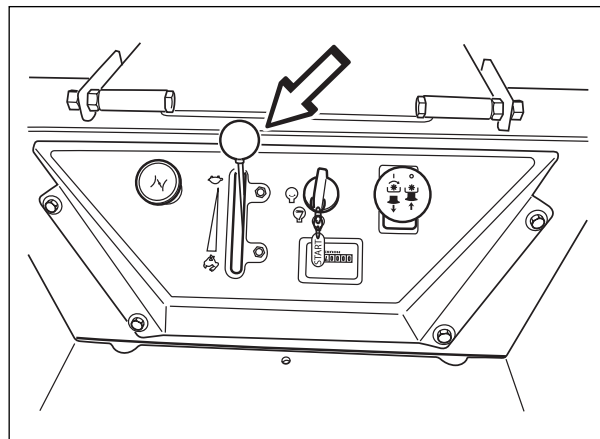

8011-509

Throttle control

Ignition Lock

The ignition key is placed on the driver's panel and is used to start the machine.

IMPORTANT INFORMATION

Do not run the start motor for more than five seconds each time. If the engine does not start, wait about 10 seconds before re-trying.

Hour Meter

The hour meter displays the total operating time.

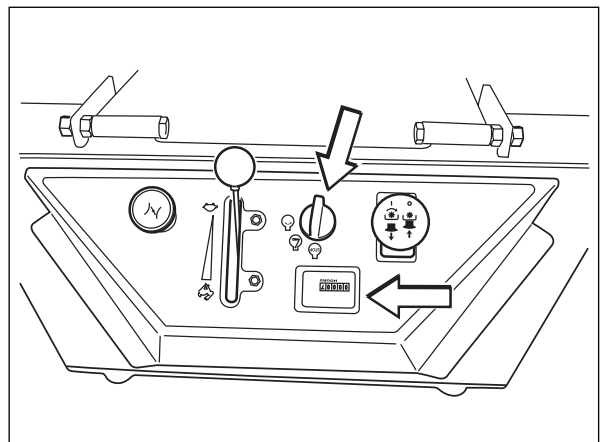

8011-521

Ignition key and hour meter

PRESENTATION

Engaging the Mower Deck

In order to engage the mower deck, pull the button out; the mower deck is disengaged when the button is depressed.

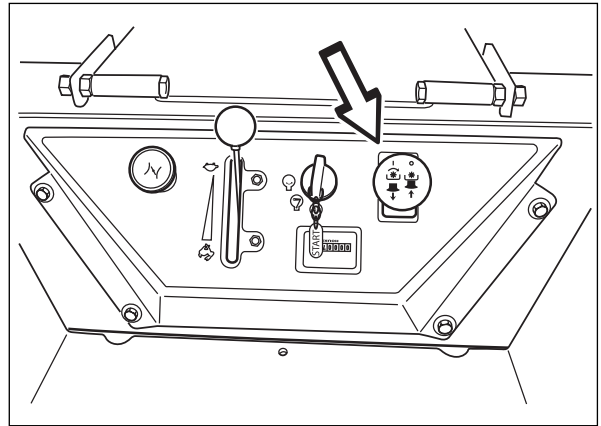

8011-510

Engaging the mower deck

Parking Brake

The parking brake is found on the left of the machine. Pull the lever backward to activate the brake and forward to release it.

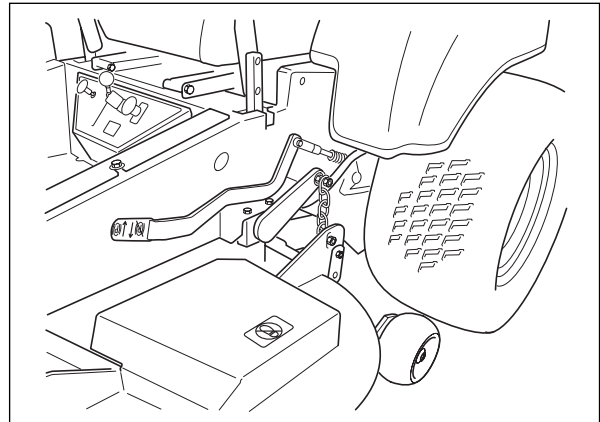

8011-511

Parking brake not activated

Seat Locking Device

To the left behind the seat is a locking device that locks the seat into its folded position. The seat has a linked fixture at the front edge and can be folded forward when the locking device is moved aside.

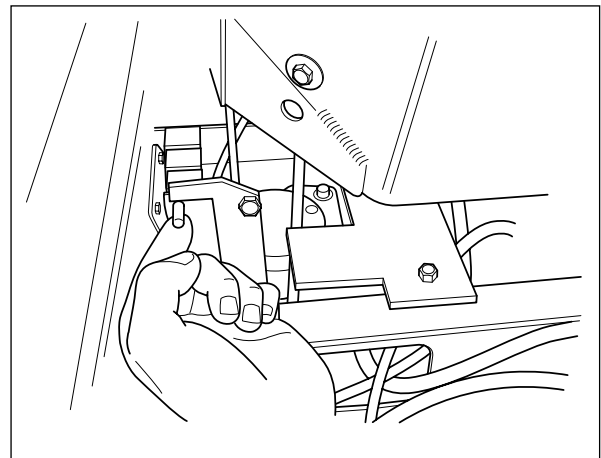

8011-523

The seat's locking device

PRESENTATION

Adjusting the Seat

The seat can be adjusted lengthways. When making adjustments, the lever under the front edge of the seat is moved to the left (as seen by the driver in the seat), after which the seat can be moved backward or forward.

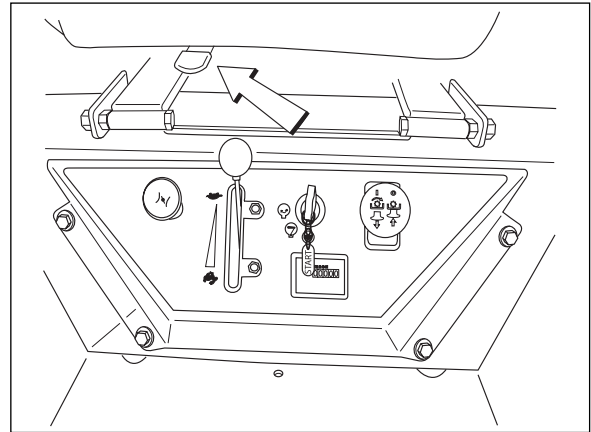

8011-562

Lengthways adjustment

Steering Controls

The machine's speed and direction are continuously variable using the two steering controls. The steering controls can be moved forward or backward about a neutral position. Furthermore, there is a neutral position, which is locked if the steering controls are moved outward.

When both controls are in the neutral position (N), the machine stands still.

By moving both controls an equal amount forward or backward, the machine moves in a straight line forward or backward respectively.

In order, for example, to turn right while moving forward, move the right control towards the neutral position. The rotation of the right wheel is reduced and the machine turns to the right.

Turning on the spot can be achieved by moving one control backward (behind the neutral position) and carefully moving the other steering control forward from its neutral position. The rotation direction when turning on the spot is determined by which steering control is moved backward behind the neutral position. If the left steering control is pulled backward, the machine turns to the left.

If the steering controls are in uneven positions when standing still or do not fit in the slots for moving the controls outward, they can be adjusted using the adjustment screws, not the link system, for the controls.

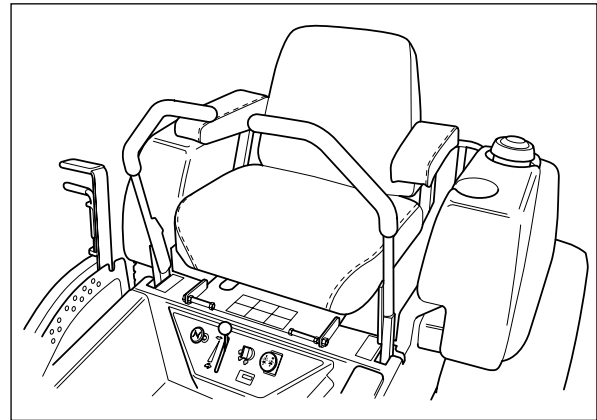

8011-522

Steering controls



WARNING!

The machine can turn very rapidly if one steering control is moved much further forward than the other.

PRESENTATION

Refueling

The machine has two fuel tanks, one on each side just behind the seat. The tanks take 22 liters each.

The engine shall be run on a minimum of 87-octane unleaded gasoline (no oil mix). Environmentally adapted alkylate gasoline can be used beneficially. See also Technical Data concerning methanol and ethanol fuels.

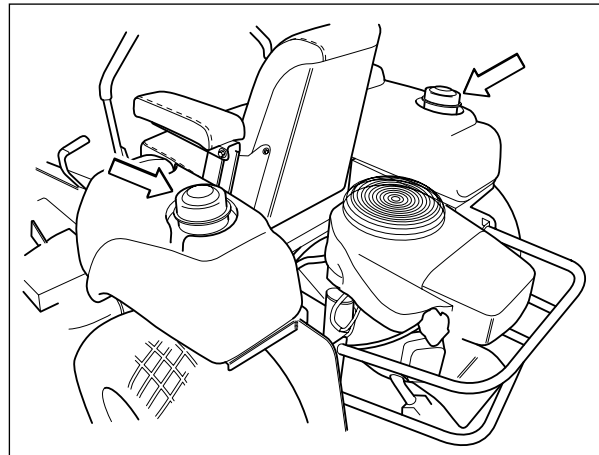
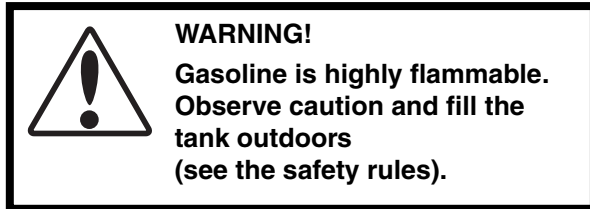

8011-524

Fuel tanks

Fuel Tap

The fuel tap is placed to the right behind the seat. The tap has three positions; right tank, left tank, and off in the middle position.

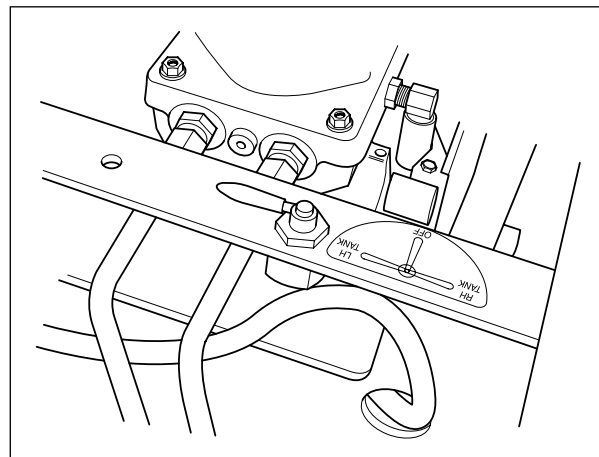

8011-506

Fuel tap

Fuses

The fuses are located in a holder to the left of the hydraulic tank. They are flat pin fuses of the same type used in automobiles.

There are two fuses, as well as sockets for two spare fuses.

Fuse ratings and functions moving from the right:

- 20 A, Primary fuse.
- 7.5 A, Mower deck coupling.
- Socket for spare fuse.
- Socket for spare fuse.

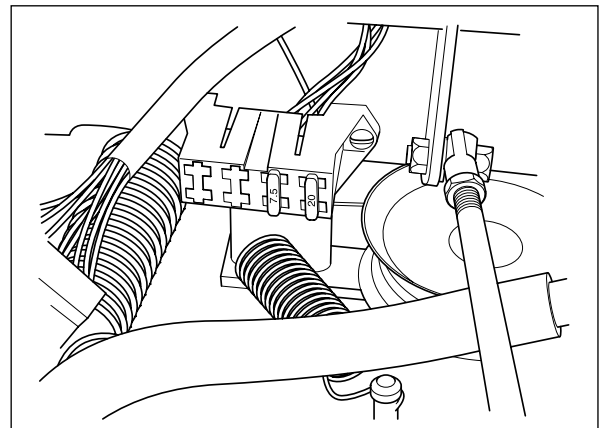

8011-596

Fuses

PRESENTATION

Lifting Lever for the Mower Deck

The lifting lever is used to place the mower deck in the transport position or one of the 17 different cutting height positions.

The cutting height is set by placing a peg in the hole for the desired cutting height and the peg is then locked on the inside (hidden in the illustration) with the supplied pin.

1. Pull the lever backward to the locked position to engage the transport position. The deck is then raised.
2. Depress the lock handle, counter hold, and move the lifting lever forward toward the peg to engage the set cutting height. The deck is then lowered.
3. The lifting lever can also be used to temporarily adjust the cutting height, such as when passing a minor bump in the lawn.

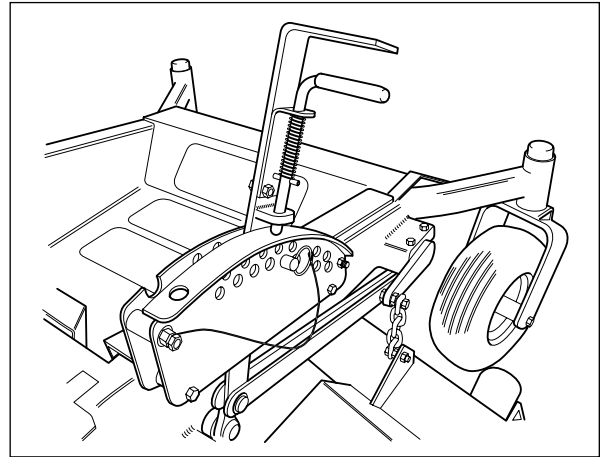

8011-525

The mower deck's lifting lever

IMPORTANT INFORMATION

In order to obtain an even cutting height it is important that the air pressure in all four tires is the same (1 bar).

Accessories

For mulching, there is a BioClip attachment available. This is mounted underneath the mower deck and comprises control plates and BioClip blades.

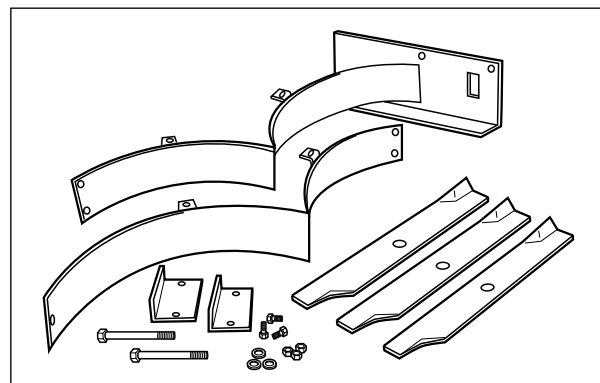

8011-566

BioClip attachment

RUNNING

Running

Before Starting

- Read the sections Safety Instructions and Presentation before starting the machine.
- Perform the daily maintenance before starting (see Maintenance Schedule in the Maintenance section).
- Check that there is sufficient fuel in the fuel tanks.
- Adjust the seat to the desired position.

The following conditions must be fulfilled before the engine can be started:

- the driver must be seated on the seat,
- the control for engaging the mower deck must be depressed,
- the parking brake must be on,
- both steering controls must be in the locked (outer) neutral position.

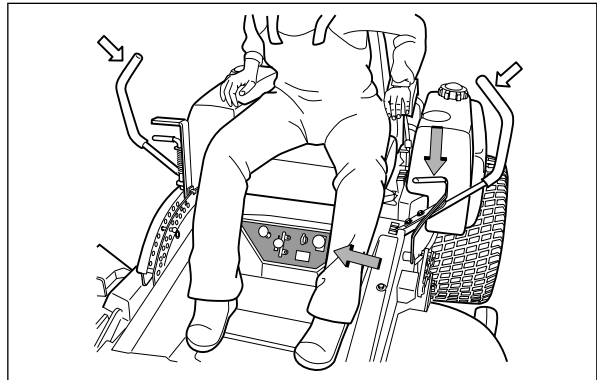

8011-527

Start conditions

Starting the Engine

1. Sit on the seat.
2. Raise the mower deck by pulling the lifting lever backward to the locked position (transport position). Activate the parking brake.

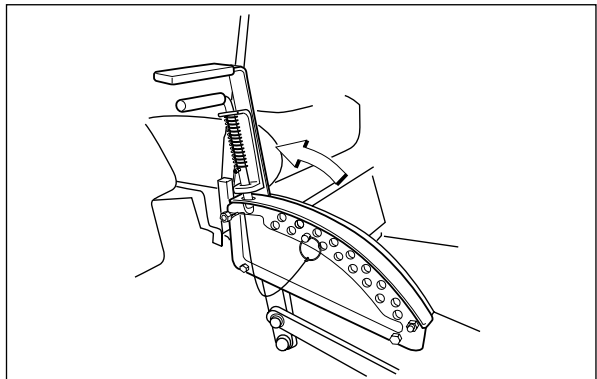

8011-552

Raise the mower deck

3. Disengage the mower deck by pressing the control.

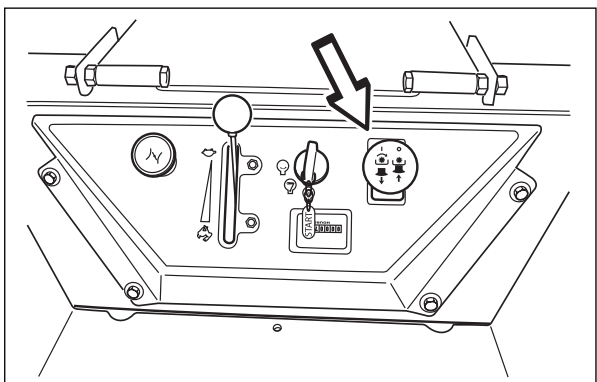

8011-510

Depress the control for disengaging the mower deck

RUNNING

4. Move the steering controls outward to the locked (outer) neutral position.

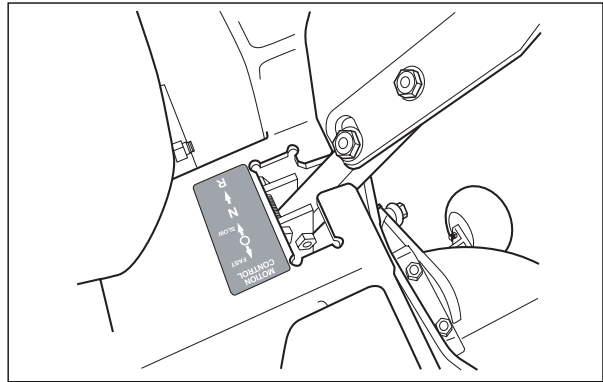

8011-526

Steering controls in the outward, locked neutral position

5. Move the throttle to the middle position.

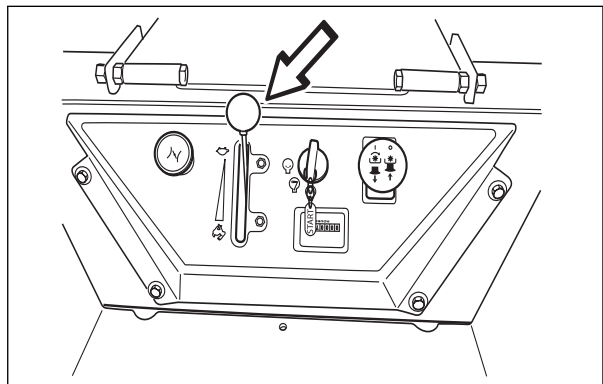

8011-509

Set the throttle

6. If the engine is cold, the choke control shall be pulled out to its end position.

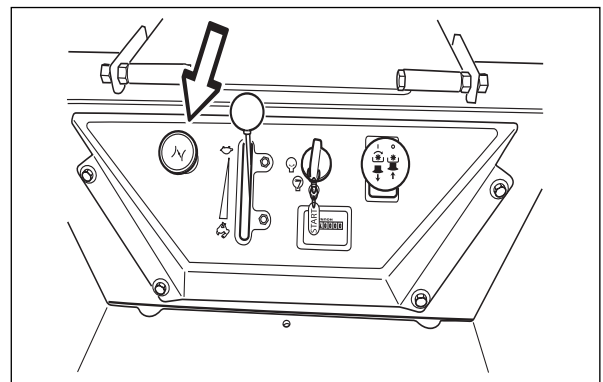

8011-508

Set the choke control

RUNNING

7. Open the fuel tap for the selected fuel tank.

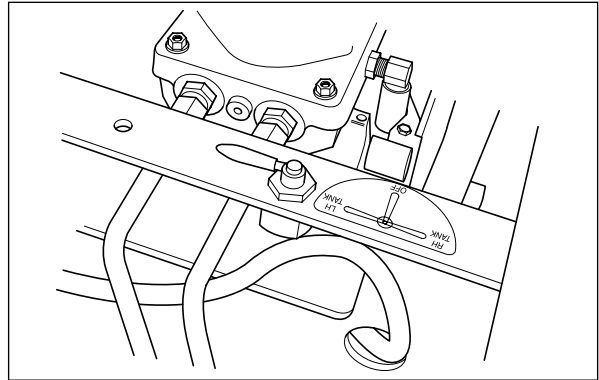

8011-506

Open the fuel tap

8. Press in and turn the ignition key to the start position.

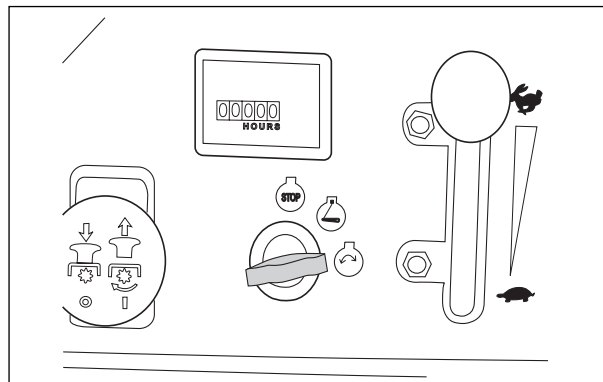

8011-559

Turn to the start position

9. When the engine starts, immediately release the ignition key back to the drive position.

IMPORTANT INFORMATION

Do not run the start motor for more than 5 seconds each time. If the engine does not start, wait about 10 seconds before re-trying.

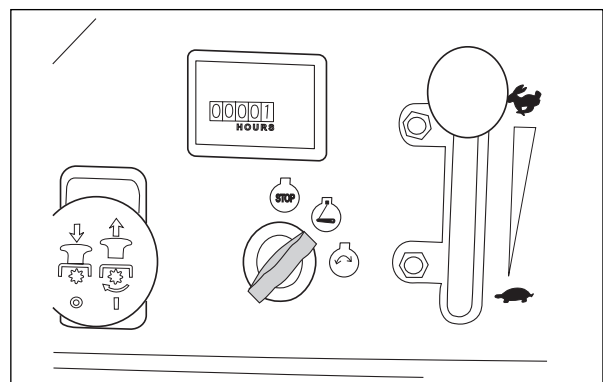

8011-560

Return to drive position

RUNNING

10. Press the choke control in gradually when the engine has started.

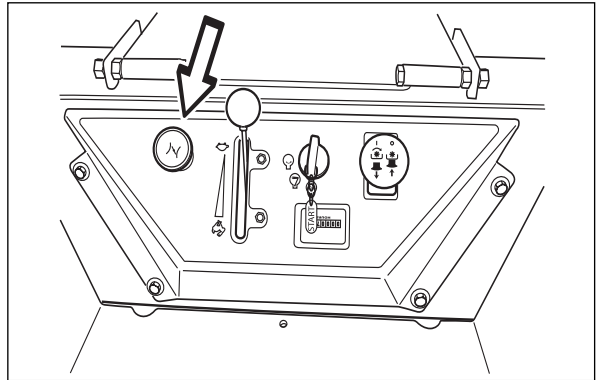

8011-508

Gradually press in the choke control

11. Set the desired engine speed with the throttle.
Allow the engine to run at a moderate speed, "half throttle", for 3-5 minutes before loading it too heavily.
Use full throttle when mowing.



WARNING!
Never run the engine indoors, in enclosed or poorly ventilated spaces. Engine exhaust fumes contain poisonous carbon monoxide.

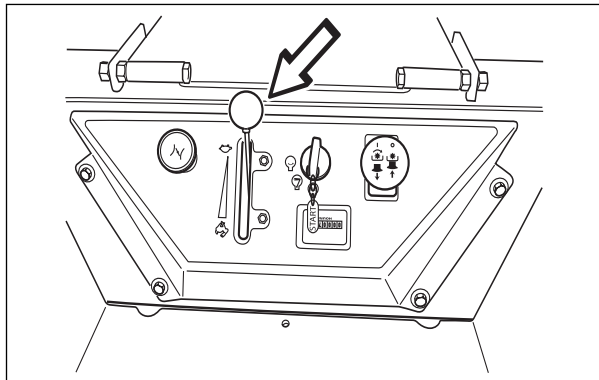

8011-509

Set the engine speed

Running

1. Move the steering controls to the neutral position (N).
2. Release the parking brake by moving the lever forward.

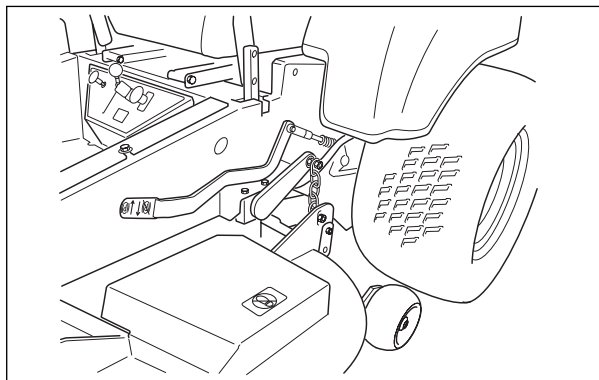

8011-511

Released parking brake

RUNNING

3. Select the cutting height by placing the peg in one of the holes. Lock the peg on the inside with the pin.
4. Press in the stop handle, counter hold, and carefully move the lifting lever forward from the transport position toward the peg.

IMPORTANT INFORMATION

The mower deck's anti-scalp rollers shall be evenly adjusted.

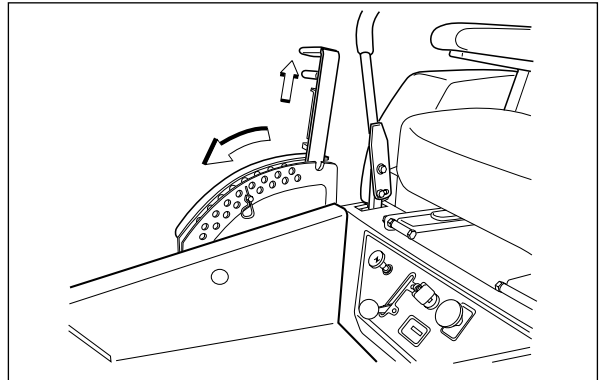

8011-561

Cutting height selection



WARNING!

Ensure that no one is near the machine when engaging the mower deck.

5. Engage the mower deck by pulling out the lever.
6. The machine's speed and direction are continuously variable using the two steering controls. When both controls are in the neutral position, the machine stands still.

By moving both controls an equal amount forward or backward, the machine moves in a straight line forward or backward respectively.

In order, for example, to turn right while moving forward, move the right control towards the neutral position. The rotation of the right wheel is reduced and the machine turns to the right.

Turning on the spot can be achieved by moving one control backward (behind the neutral position) and carefully moving the other steering control forward from its neutral position.

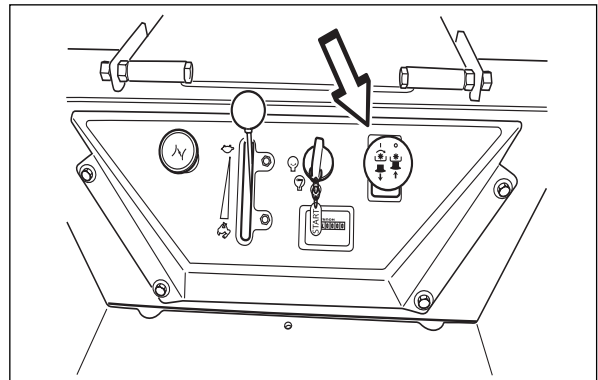

8011-510

Engaging the mower deck

RUNNING

Mowing Tips

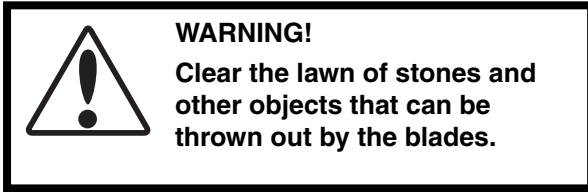

- Localise and mark rocks and other fixed objects in order to avoid collisions.
- Begin with a high cutting height and reduce it until the desired mowing result is attained.
- The mowing result will be best with a high engine speed (the blades rotate rapidly) and low speed (the rider moves slowly). If the grass is not too long and dense, the driving speed can be increased without noticeably depreciating the mowing result.
- The finest lawns are obtained by mowing often. The mowing becomes more even and the grass clippings more evenly distributed over the mown area. The total time taken is not increased as a higher driving speed can be used without poorer mowing results.
- Avoid mowing wet lawns. The mowing result is poorer because the wheels sink into the soft lawn, clumps build, and the grass clippings fasten under the cowling.
- Hose beneath the mower deck with water after each use. When cleaning, the mower deck shall be raised into the transport position.
- When the BioClip deck is used, it is extra important that the mowing interval is not too long.

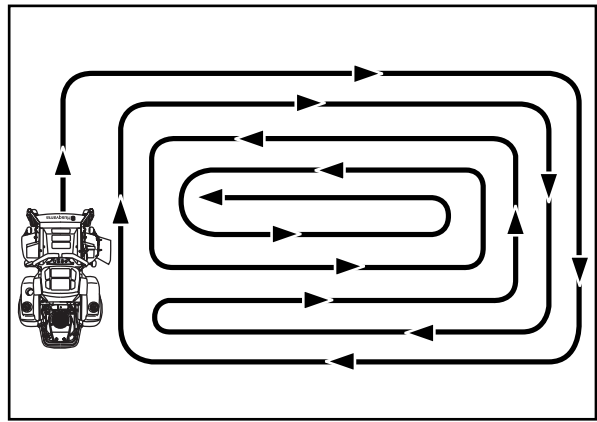

8011-603

Mowing patterns

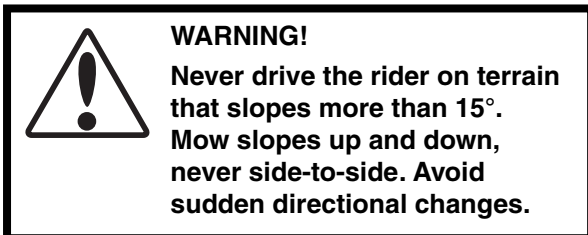

RUNNING

Stopping the Engine

Feel free to let the engine idle a minute in order to attain normal operating temperature before stopping it if it has been worked hard. Avoid idling the engine for longer periods, as there is a risk of the spark plugs gaining a coating.

1. Disengage the mower deck by depressing the control.

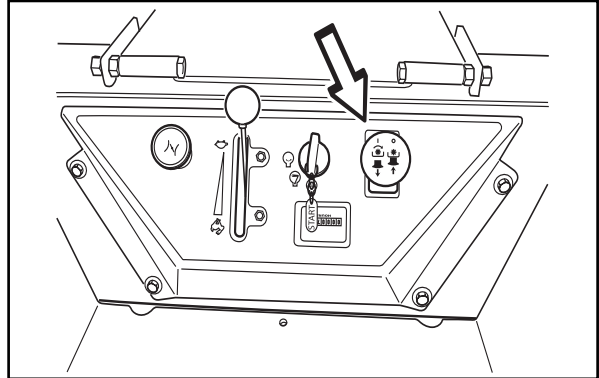

8011-510

Disengage the mower deck

2. Raise the mower deck by pulling the lifting lever backward to the transport position.
3. Move the throttle to the minimum position (tortoise symbol). Turn the ignition key to the stop position.
4. When the rider is standing still, activate the parking brake by pulling the lever backward.
5. Move the steering controls outward.

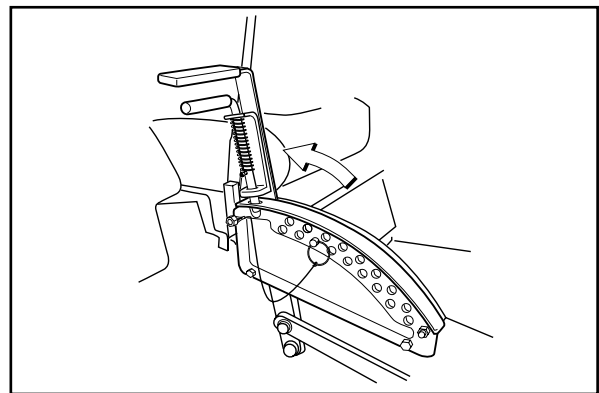

8011-552

Raise the mower deck with the lifting lever

Moving by Hand

In order for the machine to be moved with the engine turned off, the vent screws on both hydraulic pumps must be opened 1/4-1/2 turn.



WARNING!
Make no adjustments without:

- the engine stopped,
- the ignition key removed,
- the parking brake activated.

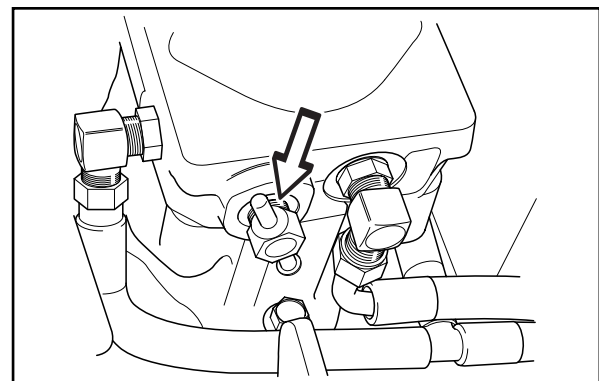

8011-507

Vent screw on the hydraulic pump

MAINTENANCE

Maintenance

Maintenance Schedule

The following is a list of maintenance procedures that must be performed on the machine. For those points not described in this manual, visit an authorized service workshop. An annual service carried out by an authorized service workshop is recommended in order to maintain your machine in the best possible condition and to ensure safe operation.

Maintenance	Page	Daily maintenance		Weekly maintenance	At least once each year	Maintenance interval in hours			
		Before	After			25	50	100	300
Check for fuel and oil leakages	-	<input type="radio"/>							
Check the parking brake	32	<input checked="" type="radio"/>							
Check the engine's oil level (every refueling)	35	<input checked="" type="radio"/>							
Check the fuel pump's air filter	31					<input checked="" type="radio"/>			
Check the safety system	27	<input checked="" type="radio"/>							
Check/clean the engine's cooling air intake	29		<input checked="" type="radio"/>						
Check the mower deck	32		<input checked="" type="radio"/>						
Check fastenings (screws, nuts, etc.)	-		<input type="radio"/>						
Start the engine and blades, listen for unusual sounds	-		<input type="radio"/>						
Clean under the mower deck	32		<input checked="" type="radio"/>						
Check the hydraulic system's oil level	34					<input checked="" type="radio"/>			
Check the condition of belts, belt pulleys, etc.	-		<input type="radio"/>						
Check for damage	-		<input type="radio"/>						
Check the tire pressures	31					<input checked="" type="radio"/>			
Thoroughly clean around the engine	-		<input type="radio"/>						
Thoroughly clean around the hydraulic system	-		<input type="radio"/>						
Clean around belts, belt pulleys, etc.	-		<input type="radio"/>						
Lubricate the belt adjuster, mower deck	37					<input checked="" type="radio"/>			
Lubricate the belt adjuster, hydraulic pumps	39					<input checked="" type="radio"/>			
Lubricate all cables	36			<input checked="" type="radio"/>					
Lubricate the driver's seat mechanism	34			<input checked="" type="radio"/>					
Lubricate the throttle	36			<input checked="" type="radio"/>					
Clean the engine's cooling air intake	29				<input checked="" type="radio"/>	<input checked="" type="radio"/>			
Lubricate links in the mower deck	-			<input type="radio"/>					
Lubricate the front wheel mounts (every 200 hours)	37							<input checked="" type="radio"/>	
Lubricate the front wheel bearings	37						<input checked="" type="radio"/>		

MAINTENANCE

Maintenance	Page	Daily maintenance		Weekly maintenance	At least once each year	Maintenance interval in hours			
		Before	After			25	50	100	300
Lubricate the steering control shafts	38						●		
Lubricate the mower deck's struts	38						●		
Lubricate the mower deck's cutting height adjuster	37						●		
Check/adjust the cutting height	-				○				
Clean the air cleaner's pre-filter (Oil-foam)	30				●	●			
Clean the air cleaner's filter cartridge ²⁾ (paper filter)	30				●		●		
Change the engine oil ¹⁾	35				●			●	
Change the hydraulic oil (every 300 hours)	-				○				○
Replace the engine oil filter (every 200 hours)	39				●			●	
Clean/replace the spark plugs	27				●			●	
Replace the fuel filter	31				●			●	
Clean the cooling fins	-				○			○	
Check the play in the engine valves ⁴⁾	-				○				○
Replace the air cleaner's pre-filter (Oil-foam)	30				●				●
Replace the air filter (paper filter) ²⁾ (every 200 hours)	30				●			●	
Perform the 300-hour service ⁴⁾	51				○				○
Check/adjust the parking brake	-				○		○		

¹⁾ First change after 8 hours. When operating with a heavy load or at high ambient temperatures, replace every 50 hours. ²⁾ In dusty conditions, cleaning and replacement are required more often. ³⁾ For daily use, the machine shall be lubricated twice weekly. ⁴⁾ Performed by authorized service workshop.

● = Described in this manual

○ = Not described in this manual



WARNING!

No adjustments or maintenance to be carried out unless:

- The engine is stopped.
- The ignition key has been removed.
- The parking brake is on.

MAINTENANCE

Ignition System

The engine is equipped with an electronic ignition system. Only the spark plugs require maintenance.

For recommended spark plugs, see Technical Data.

1. Remove the ignition cable shoe and clean around the spark plug.
2. Remove the spark plug with a 13/16" (21 mm) spark plug socket wrench.
3. Check the spark plug. Replace the spark plug if the electrodes are burned or if the insulation is cracked or damaged. Clean the spark plug with a steel brush if it is to be reused.
4. Measure the electrode gap with a gapping tool. The gap shall be 0.75 mm. Adjust as necessary by bending the side electrode.
5. Reinsert the spark plug, turning by hand to avoid damaging the threads.
6. After the spark plug is seated, tighten it using a spark plug wrench so that the washer is compressed. A used spark plug should be turned 1/8–1/4 of a turn from the seated position. A new spark plug should be turned 1/2 a turn from the seated position.
7. Replace the ignition cable shoe.

IMPORTANT INFORMATION

Fitting the wrong spark plug type can damage the engine.

Inadequately tightened spark plugs can cause overheating and damage the engine. Tightening the spark plugs too hard can damage the threads in the cylinder head.

Checking the Safety System

The machine is equipped with a safety system that prevents starting or driving under the following conditions.

The engine can only be started when:

1. The mower deck is disengaged.
2. The steering controls are in the outer, locked neutral position.
3. The driver is sitting in the driver's seat.
4. The parking brake is on.

Make daily inspections to ensure that the safety system works by attempting to start the engine when one of the conditions is not met. Change the conditions and try again.

If the machine starts when one of these conditions is not met, turn the machine off and repair the safety system before using the machine again.

Check that the engine stops if one, after having released the parking brake, temporarily stands from the driver's seat (whether the mower deck is engaged or not).

Check that the engine stops if the mower deck is engaged and one temporarily stands up.

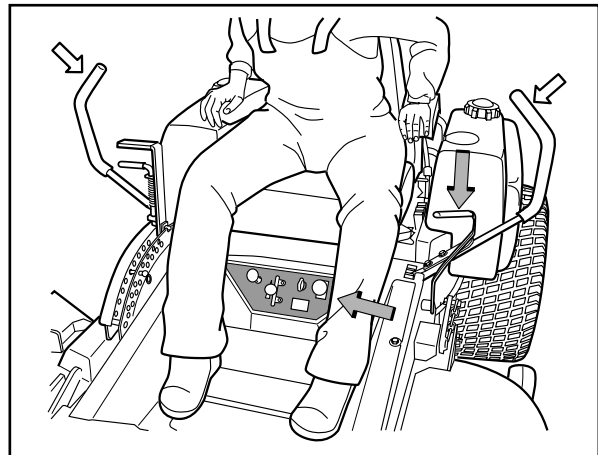

8011-527

Conditions for starting

IMPORTANT INFORMATION

In order to be able to drive, the driver must sit in the seat and release the parking brake before the steering controls can be moved into the neutral position, otherwise the engine will stop.

MAINTENANCE

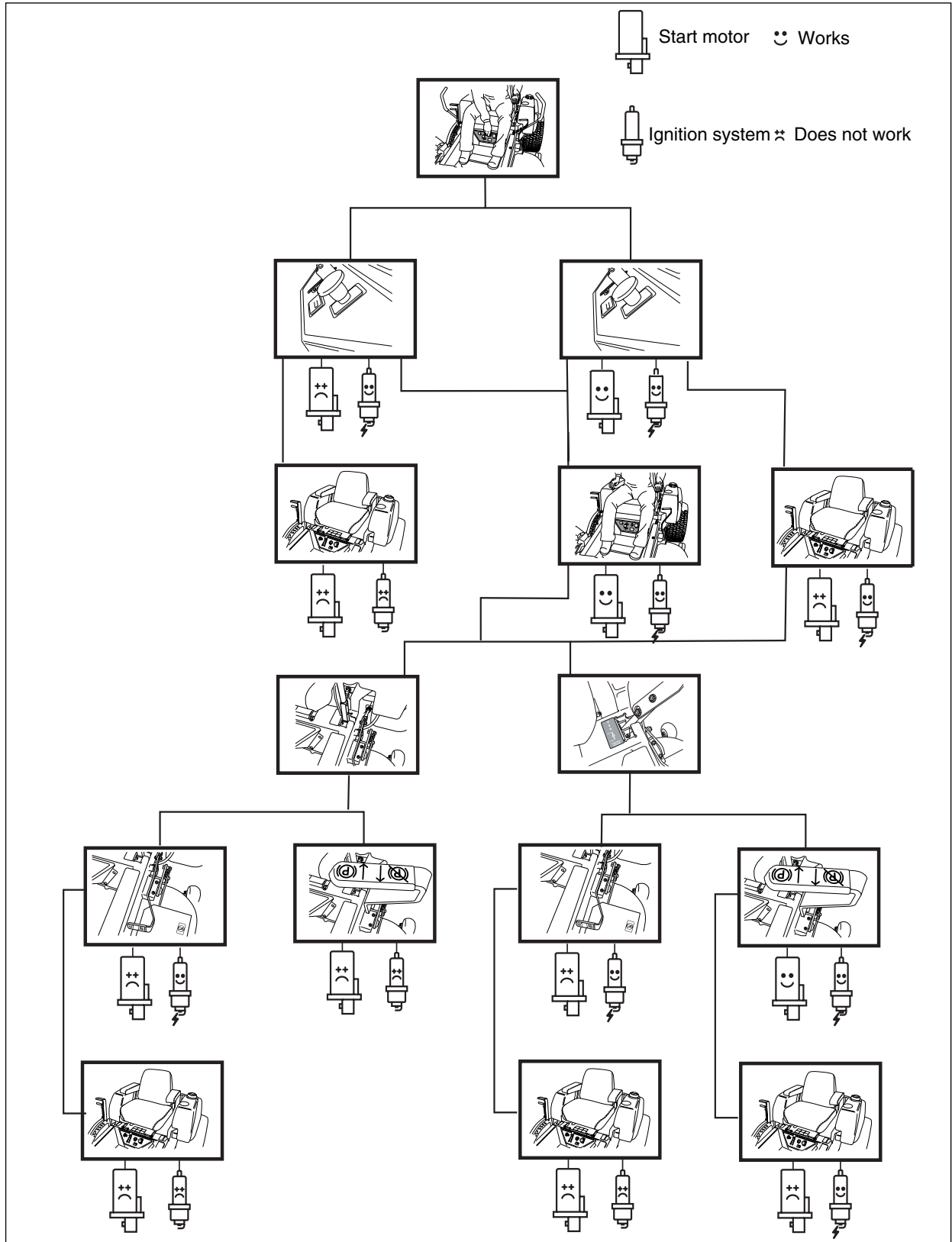

Safety system

8011-553

MAINTENANCE

Checking the Engine's Cooling Air Intake

Check that the engine's cooling air intake is free from leaves, grass, and dirt.

If the cooling air intake is clogged, engine cooling deteriorates, which can lead to engine damage.

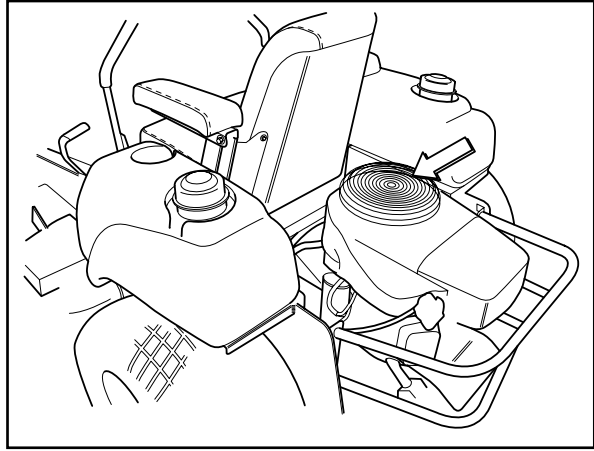

8011-625

Check and clean the cooling air intake

Checking and Adjusting the Throttle Cable

Check that the engine responds to throttle increases and that a good engine speed is attained at full throttle.

If doubts arise, contact the service workshop. If adjustments are necessary, they can be made as follows for the lower cable:

1. Loosen the clamping screw for the cable's outer casing and move the throttle to the full throttle position.
2. Check that the throttle cable is mounted in the correct hole in the lower lever, see illustration.
3. Push the throttle cable's outer casing as far to the left as possible and tighten the clamping screw.

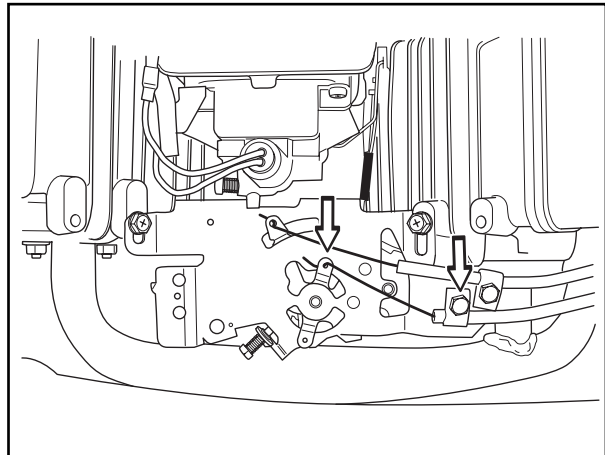

8011-554

Adjusting the throttle cable

Checking and Adjusting the Choke Cable

If the engine produces black smoke or is difficult to start, this can be because the choke cable is incorrectly adjusted (upper cable).

If doubts arise, contact the service workshop. If adjustments are necessary, they can be made as follows:

1. Loosen the clamping screw for the cable's outer casing and move the choke lever to the full choke position.
2. Check that the choke cable is mounted in the upper lever, see illustration. Push the choke cable's outer casing as far to the right as possible and tighten the clamping screw.

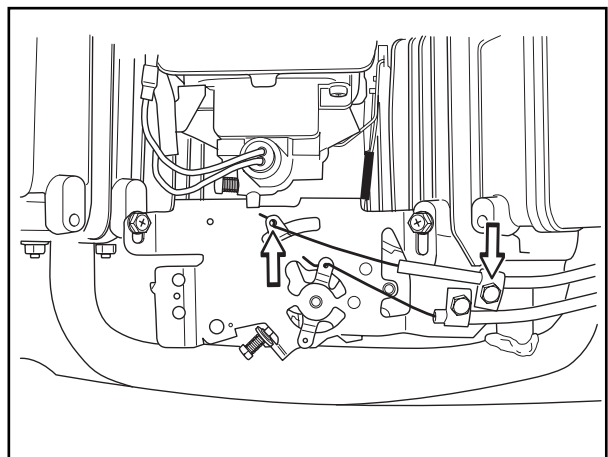

8011-555

Adjusting the choke cable

MAINTENANCE

Replacing the Air Filter

If the engine seems weak or runs unevenly, the air filter may be clogged. If run with a soiled air filter, the spark plugs can obtain a coating that disrupts operation.

For this reason, it is important to replace the air filter regularly (see the heading Maintenance Schedule for the proper service interval).

Cleaning/replacing the air filter is carried out as follows:



WARNING!

Allow the exhaust system to cool before performing service. Risk for burns.

1. Remove the two plastic fasteners on the top of the air filter cowl and remove the air filter cowl.
2. Remove the foam rubber pre-filter and clean using a mild detergent. Squeeze it dry with a clean cloth.
3. Remove the wing nuts for the air filter and remove the paper filter. Tap the paper filter against a fixed surface to remove dust. If the paper filter is still dirty, it must be replaced.

IMPORTANT INFORMATION

Do not use compressed air to clean the air filter.

Do not wash the paper filter.

Do not oil the paper filter.

4. Refit the air filter as follows:
Check that the seal on the bottom of the paper filter is whole.
Mount the paper filter in the air filter housing and tighten the wing nuts.
5. Refit the pre-filter on the paper filter.
6. Replace the cowl over the air filter housing. Do not over tighten the plastic fasteners.

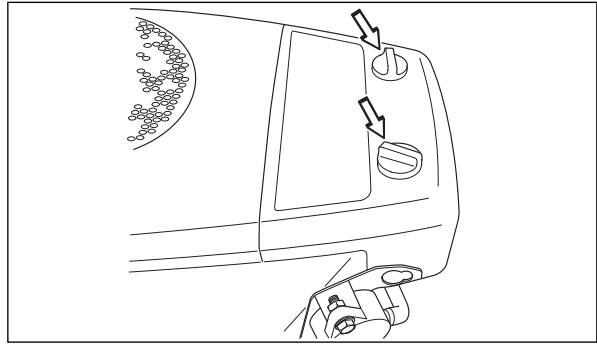

8011-556

Remove the air filter cowl

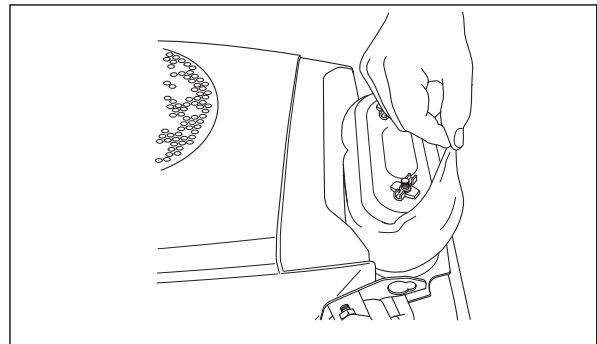

8011-557

Remove the pre-filter

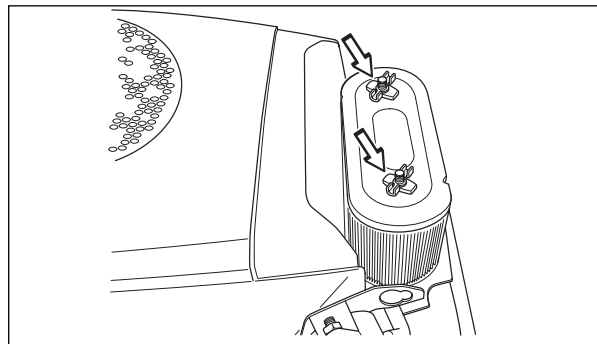

8011-558

Remove the paper filter

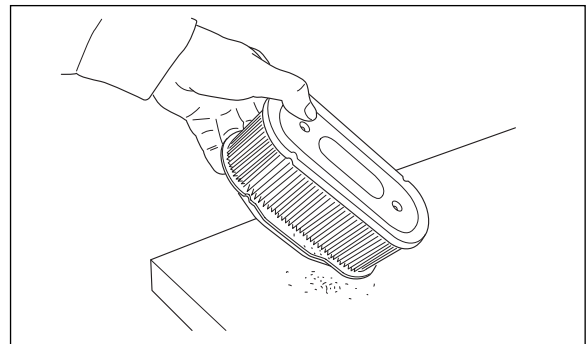

8009-181

Remove dust

MAINTENANCE

Replacing the Fuel Filter

Replace the line-mounted fuel filter every 100 hours (once per season) or more regularly if it is clogged.

Replace the filter as follows:

1. Move the hose clamps away from the filter. Use flat-nosed pliers.
2. Pull the filter loose from the hose ends.
3. Push the new filter into the hose ends. Position the filter with the "FLOW" arrow pointing up toward the fuel pump. If necessary, a soap solution can be applied to the filter ends to ease mounting.
4. Move the hose clamps back toward the filter.

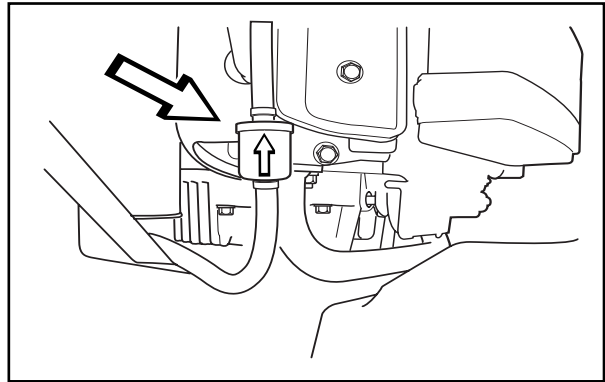

8009-146

Fuel filter

Checking the Fuel Pump's Air Filter

Regularly check that the fuel pump's air filter is free from dirt.

Remove the screws and open the pump, no hoses need be removed.

The filter can be cleaned with a brush if necessary.

Replace the filter on the console.

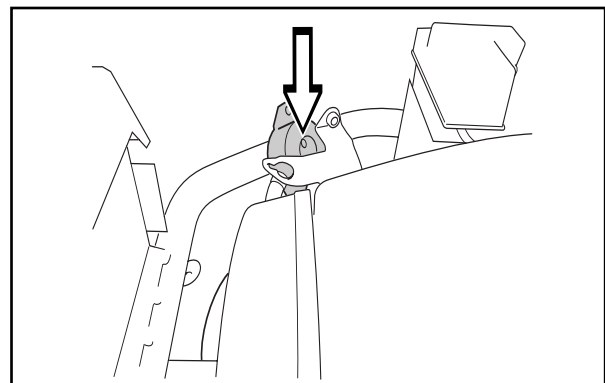

8009-147

The fuel pump's air filter

Checking Tire Pressures

All four tires shall have a pressure of 1 bar.

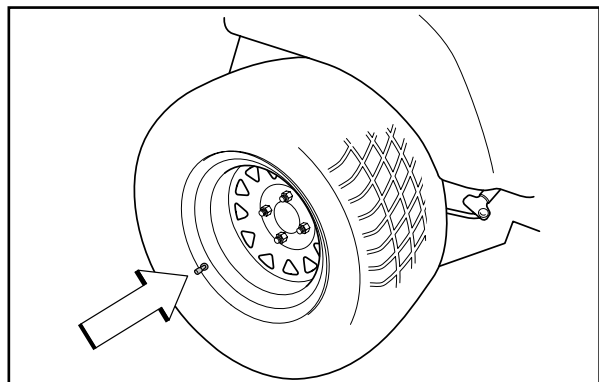

8011-564

Tire pressures

MAINTENANCE

Checking the Parking Brake

Visually check that no damage is found on the lever, links, or switch belonging to the parking brake. Perform a test drive and check that there is a braking effect.

To adjust the handbrake, contact the service workshop.

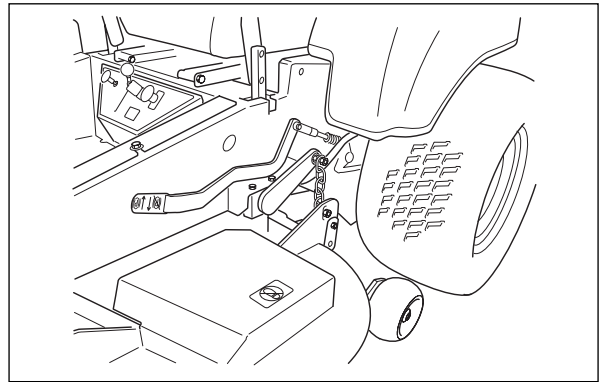

8011-511

The parking brake in the disengaged position

Checking the Blades

In order to attain the best mowing effect, it is important that the blades are well sharpened and not damaged.

Bent or cracked blades or blades with large nicks in shall be replaced.

Check the blade mounts.

IMPORTANT INFORMATION

The replacement or sharpening of blades ought to be carried out by an authorized service workshop.

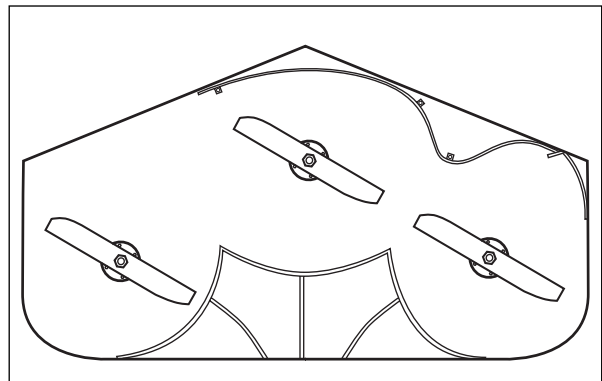

8011-604

Check the blades

Damaged blades should be replaced when hitting obstacles that result in a breakdown. Let the service workshop decide whether the blade can be repaired/ground or must be discarded.

Adjusting the Mower Deck

Contact an authorized service workshop.

Cleaning and Washing

Regular cleaning and washing, especially under the mower deck, will increase the machine's lifespan. Make it a habit to clean the machine directly after use, before the dirt sticks.

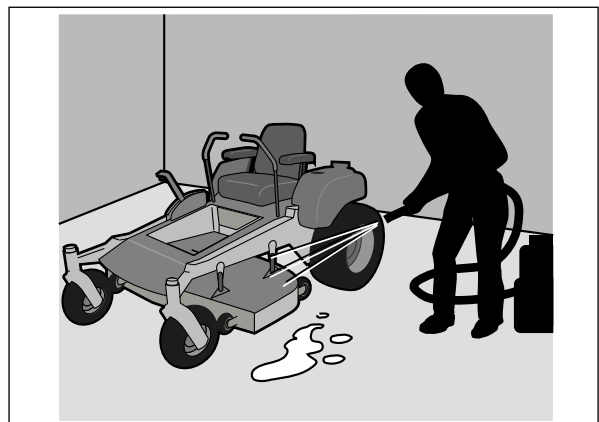

8011-514

Cleaning

LUBRICATION

Lubricating the Cables

If possible, grease both ends of the cables and move the controls to end stop positions when lubricating. Refit the rubber covers on the cables after lubrication. Cables with sheaths will bind if they are not lubricated regularly. If a cable binds, it can disrupt operation.

If a cable binds, remove the cable and hang it vertically. Lubricate it with thin engine oil until the oil begins to escape from the bottom.

Tip: Fill a small plastic bag with oil and tape it so that it seals against the sheath and allow the cable to hang vertically from the bag overnight. If you do not succeed in lubricating the cable, it must be replaced.

Lubricating in Accordance with the Lubrication Schedule

1. Hydraulic System, Oil Level

The hydraulic oil and filter shall be replaced every 300 hours, and at least once a year. Contact an authorized service workshop.

Check the oil level in the hydraulic tank daily. The level shall be about 19 - 25 mm (3/4"-1") below the top of the tank.

Check connections, hoses, and tubes for damage or leaks. Replace or repair if doubtful.

Changing Oil and Filters

Oil and filter changes shall be carried out by an authorized service workshop and are described in the Workshop Manual.

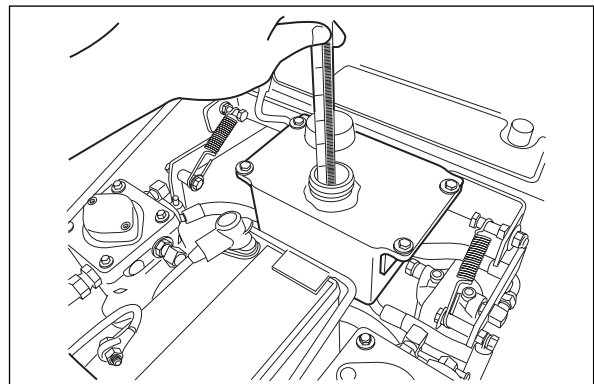

8011-565

Checking the hydraulic oil

2. Driver's Seat

Tip the seat.

Lubricate the linked mount at the front using an oilcan.

Lubricate the lengthways adjustment mechanism with the oilcan.

Lubricate the lengthways adjustment runners with the oilcan.

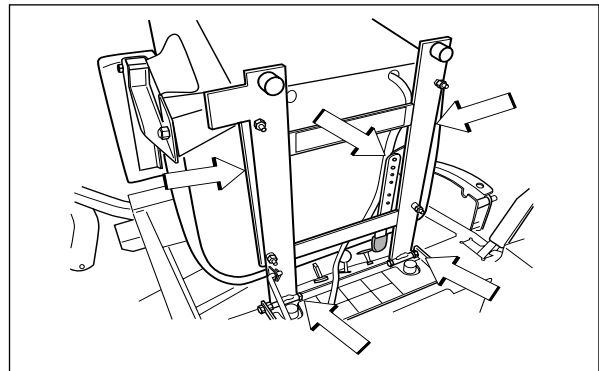

8011-571

Lubricating the lengthways adjuster under the seat

LUBRICATION

3. Engine Oil

Changing the Engine Oil

The engine oil shall be changed for the first time after 8 hours of operation. Thereafter, it shall be changed every 100 hours.



WARNING!

Engine oil can be very hot if it is drained directly after stopping the engine. Allow the engine to cool somewhat first.

IMPORTANT INFORMATION

Used engine oil is a health hazard and must not be disposed of on the ground or in nature; it should always be disposed of at a workshop or appropriate disposal location.

Avoid skin contact; wash with soap and water in case of spills.

1. Place the machine on a flat surface.
2. Place a container under the engine where the hose from the oil drainage tap exits.
3. Remove the dipstick and open the drainage tap.
4. Allow the oil to run out into the container.
5. Then close the oil drainage tap.
6. Replace the oil filter if necessary.
7. Fill with new engine oil in accordance with Checking the Oil Level.

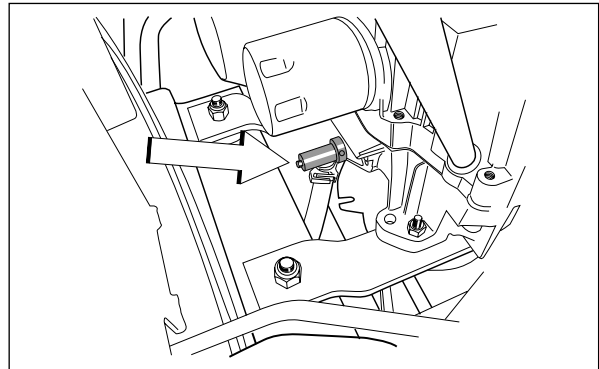

8011-572

Oil drainage tap

Checking the Oil Level

Check the oil level in the engine when the machine is standing horizontally and the engine is stopped.

Remove the dipstick, wipe it clean, and then replace it.

The dipstick shall **not** be screwed into place.

Take the dipstick out again and read the oil level.

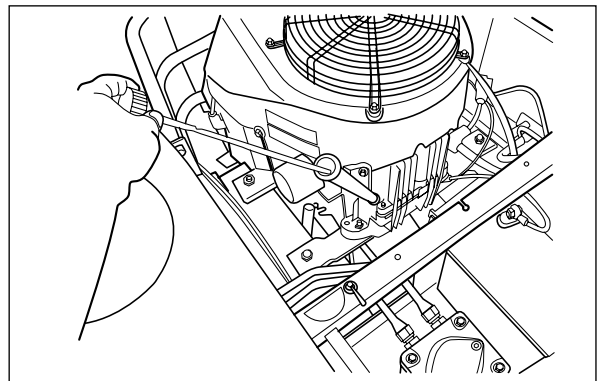

8011-569

Remove the dipstick

LUBRICATION

The oil level shall lie between the markings on the dipstick. If the level is approaching the "ADD" mark, top up the oil to the "FULL" mark on the dipstick.

Never fill to above the "FULL" mark.

The oil is topped up through the hole the dipstick sits in.

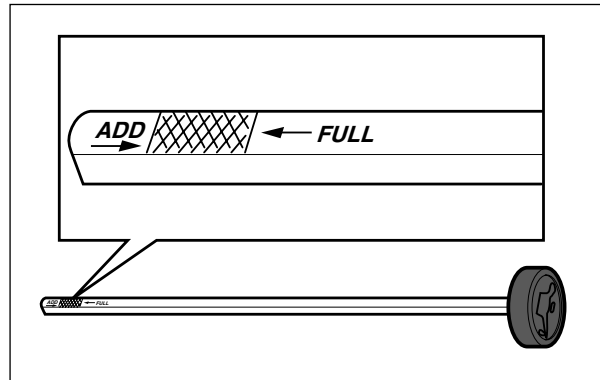

8009-159

The dipstick markings

Use engine oil SAE 30 or SAE 10W-30 or, alternately, 10W/40, class SC-SH (over 0 °C/+32 °F).

Over +20 °C/+68 °F SAE 40 can be used.

Use engine oil SAE 5W-20, class SC-SH (under 0 °C/+32 °F).

The engine holds 1.5 liters of oil excluding the filter (including filter 1.7 liters).

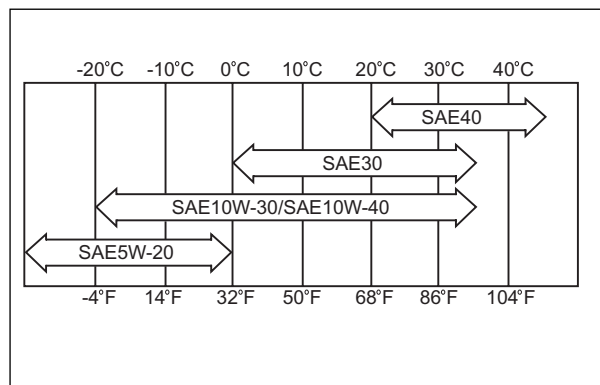

8009-140

Engine oils

4. Throttle and Choke Cables, Lever Bearings

Lubricate the cable ends by the carburetor with the oilcan. Move the controls to the end points and lubricate again.

The throttle cable is also lubricated by the control when the control console is removed.

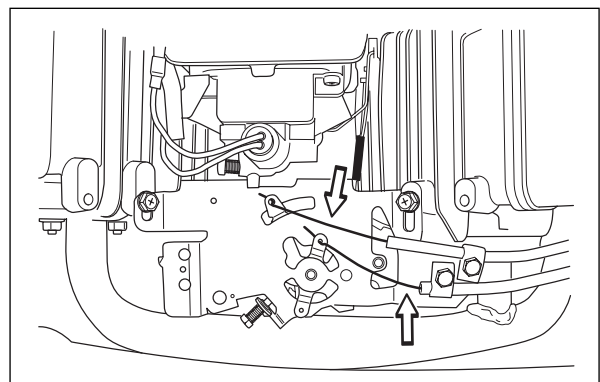

8011-605

Throttle and choke cables by the carburetor

LUBRICATION

5. Front Wheel Mount

Lubricate with a grease gun, 1 nipple for each wheel mount, until the grease is forced out.

Use only good quality molybdenum disulphide grease.

Grease from well-known brand names (petrochemical companies, etc.) usually maintains a good quality.

6. Front Wheel Bearings

Lubricate with a grease gun, 1 nipple for each set of wheel bearings, until the grease is forced out.

Use only good quality molybdenum disulphide grease.

Grease from well-known brand names (petrochemical companies, etc.) usually maintains a good quality.

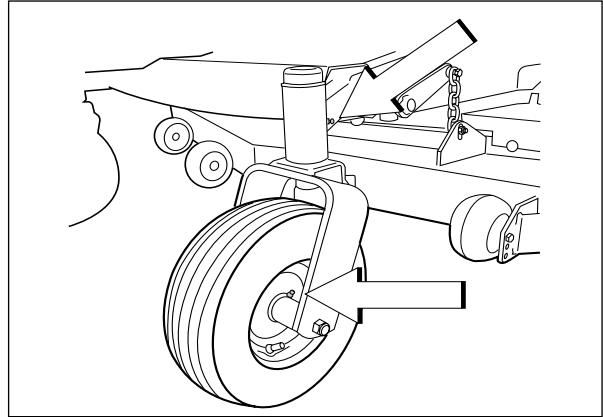

8011-573

Lubricating the front wheels

7. Belt Adjuster, Mower Deck

Remove the foot plate (two screws) and lubricate with a grease gun, 1 nipple, until grease is forced out.

Use only good quality molybdenum disulphide grease.

Grease from well-known brand names (petrochemical companies, etc.) usually maintains a good quality.

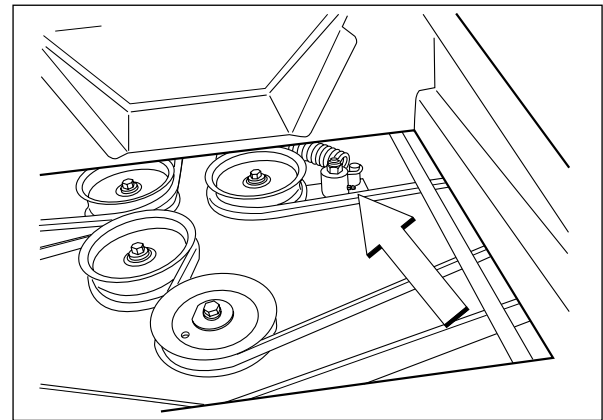

8011-576

The belt adjuster grease nipple

IMPORTANT INFORMATION

Be spartan and remove excess lubricant so that it does not come into contact with belts or belt pulley drive surfaces.

8. Mower Deck Height Adjuster

Lubricate using a grease gun, 1 nipple, until the grease squeezes out.

Use only good quality molybdenum disulphide grease.

Grease from well-known brand names (petrochemical companies, etc.) usually maintains a good quality.

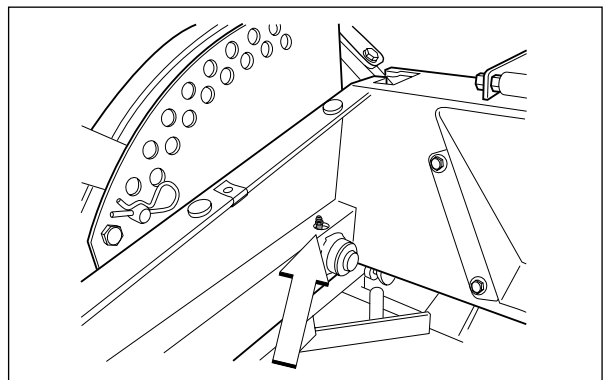

8011-574

Lubricating the cutting height adjuster

LUBRICATION

9. Steering Control Shafts

Tip the driver's seat.

Lubricate with a grease gun, 1 nipple for each steering control shaft, until the grease is forced out.

Use only good quality molybdenum disulphide grease.

Grease from well-known brand names (petrochemical companies, etc.) usually maintains a good quality.

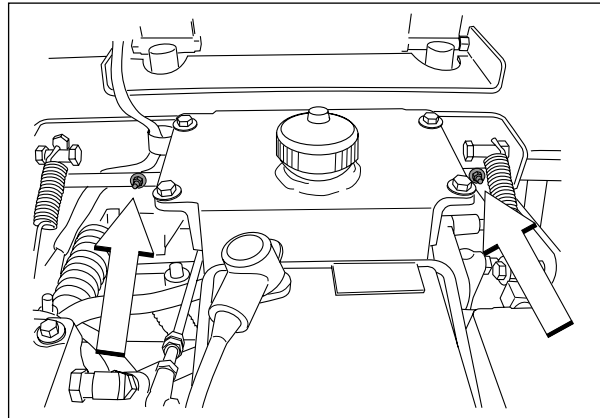

8011-578

Lubricating the steering control shafts

10. Mower Deck Struts

Lubricate with a grease gun, 1 nipple for each strut, until the grease is forced out.

Use only good quality molybdenum disulphide grease.

Grease from well-known brand names (petrochemical companies, etc.) usually maintains a good quality.

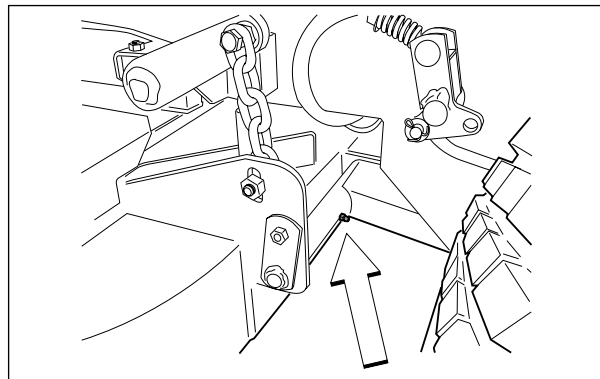

8011-577

Lubricating struts

11. Brake Arms

Remove one rear wheel at a time (four screws).

Lubricate with a grease gun, 1 nipple for each brake arm, until the grease is forced out.

Use only good quality molybdenum disulphide grease.

Grease from well-known brand names (petrochemical companies, etc.) usually maintains a good quality.

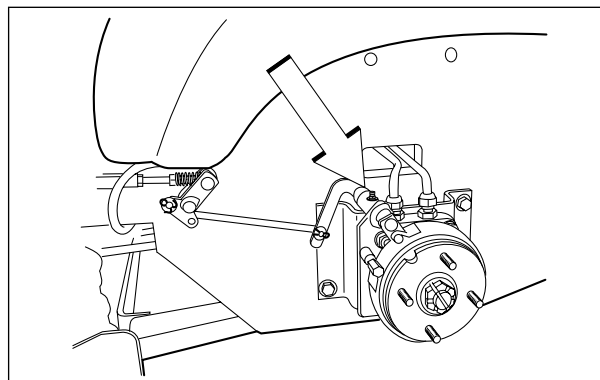

8011-579

Lubricating brake arms

IMPORTANT INFORMATION

Be spartan and remove excess lubricant so that it does not come into contact with the brake band.

LUBRICATION

12. Belt Adjuster, Hydraulic Pumps

Lubricate using a grease gun, 1 nipple, until the grease squeezes out.

Use only good quality molybdenum disulphide grease.

Grease from well-known brand names (petrochemical companies, etc.) usually maintains a good quality.

IMPORTANT INFORMATION

Be spartan and remove excess lubricant so that it does not come into contact with belts or belt pulley drive surfaces.

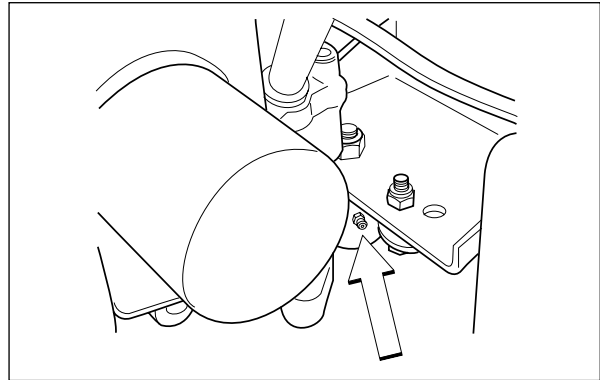

8011-575

Lubricating the belt adjuster

13. Changing the Oil Filter

1. Drain the engine oil in accordance with the work description under the heading Engine Oil/Change Engine Oil.
2. Disassemble the oil filter. If necessary, use a filter remover.
3. Wipe new, clean engine oil onto the seal for the new filter.
4. Mount the filter by hand with + 3/4 turn.
5. Run the engine warm, then check that there are no leaks around the oil filter seal.
6. Check the oil level in the engine, top up if necessary. The oil filter holds 0.2 liters of oil.

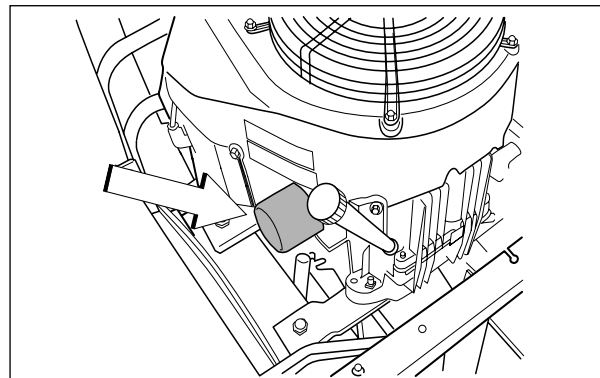

8011-570

Changing the oil filter

TROUBLE SHOOTING GUIDE

Trouble Shooting Guide

Problem**Cause**

The engine will not start.

- The control for engaging the mower deck is not depressed.
- The steering controls are not locked in the neutral position.
- The driver is not sitting in the driver's seat.
- The parking brake is not activated.
- The battery is dead.
- Contamination in the carburetor or fuel line.
- The fuel supply is closed or the tap for the fuel tanks is in the wrong position.
- Clogged fuel filter or fuel line.

The starter motor does not turn the engine over.

- Dead battery.
- Poor contacts on the battery terminal cable connections.
- Fuse blown.
- Ignition system faulty.
- Fault in the starter motor safety circuit. See Safety system on page 28.

The engine runs unevenly.

- Faulty carburetor.
- The choke control is pulled out with a warm engine.
- Defective valves.
- Defective piston, cylinder, piston ring, or cylinder head seal.
- The cylinder head bolts are loose.
- Clogged fuel filter or jet.
- Clogged ventilation valve on the fuel cap.
- Fuel tank empty.
- Defective spark plugs.
- The spark plugs are loose.
- Defective ignition cable.
- Defective spark plug electrode.
- Defective spark plug connection.
- Rich fuel mixture or fuel-air mixture.

TROUBLE SHOOTING GUIDE

- Wrong fuel type.
- Water in the fuel.
- Clogged air filter.

The engine seems weak.

- Clogged air filter.
- Defective spark plugs.
- Carburetor incorrectly adjusted.

The engine overheats.

- Clogged air intake or cooling fins.
- Engine overloaded.
- Poor ventilation around engine.
- Defective engine speed regulator.
- Soot in the combustion chamber.
- Too little or no oil in the engine.
- Defective spark plugs.
- Pre-ignition incorrect.

Battery not charging.

- Poor contact with battery terminal cable connectors.

The machine moves slowly, unevenly,
or not at all.

- Parking brake on.
- Venting valve on pump open.
- Drive belt for the pump slack or has come off.
- Defective hydraulic system.
- Air in the hydraulic system.

Mower deck not engaging.

- Drive belt for the mower deck has come loose.
- Contact for the electromagnetic coupling has loosened.
- The control for engaging the mower deck is faulty or has come loose from the cable contact.
- The fuse has blown.

Uneven mowing results.

- Different air pressure in the tires on the left and right sides.
- Bent blades.
- The chains for suspending the mower deck

TROUBLE SHOOTING GUIDE

are uneven.

- The chain fixture has come loose.
- The blades are blunt.
- Driving speed too high.
- The grass is too long.
- Grass collected under the mower deck.

The machine vibrates.

- The blades are loose.
 - The blades are incorrectly balanced.
 - The engine is loose.
-

STORAGE

Storage

Winter Storage

At the end of the mowing season, the machine should be readied for storage (or if it will not be in use for longer than 30 days). Fuel allowed to stand for long periods of time (30 days or more) can leave sticky residues that can plug the carburetor and disrupt engine function.

Fuel stabilizers are an acceptable option as regards sticky residues during storage. If alkylate gasoline (Aspen) is used, stabilizers are unnecessary because this fuel is stable. However, you should avoid switching between regular and alkylate gasoline as sensitive rubber components can harden. Add stabilizer to the fuel in the tank or in the storage container. Always use the mixing ratios specified by the manufacturer of the stabilizer. Run the engine for at least 10 minutes after adding the stabilizer so that it reaches the carburetor. Do not empty the fuel tank and the carburetor if you have added stabilizer.



WARNING!

Never store an engine with fuel in the tank indoors or in poorly ventilated spaces where fuel vapor can come in contact with open flames, sparks, or a pilot light such as in a boiler, hot water tank, clothes drier, etc. Handle the fuel with care. It is very flammable and careless use can cause serious personal injury and property damage. Drain the fuel into an approved container outdoors and far away from open flame. Never use gasoline for cleaning. Use a degreaser and warm water instead.

To ready the machine for storage, follow these steps:

1. Thoroughly clean the machine, especially under the mower deck. Touch up damage to the paint and spray a thin layer of oil on the underside of the mower deck in order to avoid corrosion.
2. Inspect the machine for worn or damaged parts and tighten any nuts or screws that may have become loose.
3. Change the engine oil; dispose of properly.
4. Empty the fuel tanks or add a fuel stabilizer. Start the engine and allow it to run until even the carburetor is drained of fuel or the stabilizer has reached the carburetor.
5. Remove the spark plugs and pour about a tablespoon of engine oil into each cylinder. Turn over the engine so that the oil is evenly distributed and then refit the spark plugs.
6. Lubricate all grease nipples, joints, and axles.
7. Remove the battery. Clean, charge, and store the battery in a cool place, but protect it from direct cold.
8. Store the machine in a clean, dry place and cover it for extra protection.

Service

When ordering spare parts, please specify the purchase year, model, type, and serial number.

Always use genuine Husqvarna spare parts.

An annual check-up at an authorized service workshop is a good way to ensure that your machine performs its best the following season.

TECHNICAL DATA

Technical Data

Meas., Weights, Etc.	ZTH5223	ZTH6125
Length	2,057 mm (81 in.)	2,057 mm (81 in.)
Width (lowered discharge deck)	1,600 mm (63 in.)	1,829 mm (72 in.)
Width (raised discharge deck)	1,346 mm (53 in.)	1,575 mm (62 in.)
Height	1,073 mm (42.25 in.)	1,073 mm (42.25 in.)
Weight	464.5 kg (1,024 lbs)	464.5 kg (1,024 lbs)
Air pressure, front and rear	1 bar (15 psi)	1 bar (15 psi)
Tires, front	Carlisle 13" x 5.00 - 6 tubeless	Carlisle 13" x 5.00 - 6 tubeless
Tires, rear	Carlisle 24" x 12.00 - 12 tubeless	Carlisle 24" x 12.00 - 12 tubeless
Driver's seat	Adjustable lengthways with arm rests	Adjustable lengthways with arm rests
Speed, forward	Variable; max. 12.9 km/h (8 mph)	Variable; max. 12.9 km/h (8 mph)
Speed, backward	Variable; max. 3.23 km/h (2 mph)	Variable; max. 3.23 km/h (2 mph)

Engine

Manufacturer	Kawasaki	Kawasaki
Model	FH680V-AS15	FHV721V-AS04
Power	23 hp	25 hp
Cylinder volume	675 cm ³ (41.19 cu. in.)	675 cm ³ (41.19 cu. in.)
Max. engine speed	2,950 rpm	2,950 rpm
Idle speed	1,550 rpm	1,550 rpm
Fuel tanks	2 @ 22 liters each (11.4 Gal.)	2 @ 22 liters each (11.4 Gal.)
Nominal action time	11 hours	11 hours
Fuel	Min. 87 octane unleaded (Max. methanol 5%, max. ethanol 10%, max. MTBE 15%)	Min. 87 octane unleaded (Max. methanol 5%, max. ethanol 10%, max. MTBE 15%)
Oil	SAE 30 or SAE 10W/30, SAE 10W/40 class SC -SH	SAE 30 or SAE 10W/30, SAE 10W/40 class SC -SH
Oil volume	1.5 liters / 1.6 US qt	1.5 liters / 1.6 US qt
Oil volume incl. filter	1.7 liters / 1.8 US qt	1.7 liters / 1.8 US qt
Start	Electric start	Electric start

TECHNICAL DATA

Noise Emissions and Cutting Width

Measured noise level	104 dB(A)	104 dB(A)
Guaranteed noise level	105 dB(A)	105 dB(A)
Cutting width	1,321 mm (52 in.)	1,549 mm (61 in.)

Electrical System

Type	12 V, negative earth	12 V, negative earth
Battery	12 V, maintenance-free	12 V, maintenance-free
Primary fuse	Flat pin 20 A	Flat pin 20 A
Spark plug	NGK BPR4ES	NGK BRR1550
Coupling, mower deck	Electromagnetic	Electromagnetic

Transmission

Hydrostatic drive	2 axial piston pumps with Parker Ross wheel motors	2 axial piston pumps with Parker Ross wheel motors
Hydraulic oil, volume	1.9 liters (2 qt.)	1.9 liters (2 qt.)
Hydraulic oil, type	15W-50 Synthetic	15W-50 Synthetic

Mower Deck

Cutting width	1,321 mm (52 in.)	1,549 mm (61 in.)
Cutting height	Adjustable 38 - 152 mm in 6.4 mm steps	Adjustable 38 - 152 mm in 6.4 mm steps
Blade length	457.2 mm (18 in.)	533,4 mm (21 in.)
Anti-scalp rollers	Adjustable, 6	Adjustable, 6

Accessories

BioClip attachment
Foot operated mower deck (ZTH5223)
Tip protector

When this product is worn out and no longer used, it shall be returned to the reseller or other party for recycling.

In order to implement improvements, specifications and designs can be altered without prior notification.

Note that no legal demands can be placed based on the information contained in these instructions.

Use only original parts for repairs. The use of other parts voids the guarantee.

SERVICE JOURNAL

Service Journal

Action	Date, mtr reading, stamp, sign
Delivery Service	
1. Charge the battery.	<input type="checkbox"/>
2. Mount the rear wheels.	<input type="checkbox"/>
3. Adjust the tire pressure of all wheels to 1 bar (15 PSI).	<input type="checkbox"/>
4. Mount the steering controls in the normal position.	<input type="checkbox"/>
5. Connect the lever to the seat stop.	<input type="checkbox"/>
6. Connect the contact box to the cable for the seat's safety switch.	<input type="checkbox"/>
7. Mount the arm rests on the seat's back support.	<input type="checkbox"/>
8. Check that the right amount of oil is in the engine.	<input type="checkbox"/>
9. Check that the right amount of oil is in the hydraulic tank.	<input type="checkbox"/>
10. Adjust the position of the steering controls.	<input type="checkbox"/>
11. Fill with fuel and open the fuel tap.	<input type="checkbox"/>
12. Connect the exhaust fumes extractor.	<input type="checkbox"/>
13. Start the engine.	
14. Check that there is drive to both wheels.	<input type="checkbox"/>
15. Vent the hydraulic system if necessary.	<input type="checkbox"/>
16. Check the mower deck adjustment.	<input type="checkbox"/>
17. Check:	
The safety switch for the parking brake.	<input type="checkbox"/>
The safety switch for the mower deck.	<input type="checkbox"/>
The safety switch in the seat.	<input type="checkbox"/>
The safety switch in the steering controls.	<input type="checkbox"/>
Parking brake functionality.	<input type="checkbox"/>
Driving forward.	<input type="checkbox"/>
Driving backward.	<input type="checkbox"/>
Engaging the blades.	<input type="checkbox"/>
18. Check the idle speed 1550±50 rpm.	<input type="checkbox"/>
19. Check the engine speed 2950±75 rpm	<input type="checkbox"/>

SERVICE JOURNAL

Action	Date, mtr reading, stamp, sign
<p>20. Inform the customer about:</p> <ul style="list-style-type: none">The need and advantages of following the service schedule.The need and advantages of leaving the machine for service every 300 hours.The effects of service and maintaining a service journal on the machine's resale value.Application areas for BioClip. <p>21. Fill in the sales papers, etc.</p>	<p>Delivery service has been carried out.</p> <p>No remaining notes.</p> <p>Certified:</p>
<p>After the First 8 Hours</p> <p>1. Change engine oil.</p>	<input type="checkbox"/>

SERVICE JOURNAL

Action	Date, mtr reading, stamp, sign
<p>25-Hour Service</p> <ol style="list-style-type: none">1. Check the fuel pump's air filter.2. Check the hydraulic system's oil level.3. Check the tire pressures.4. Lubricate the belt adjuster, mower deck.5. Lubricate the belt adjuster, hydraulic pumps.6. Check/clean the engine's cooling air intake.7. Clean the air cleaner's pre-filter (Oil-foam).	

SERVICE JOURNAL

Action	Date, mtr reading, stamp, sign
<p>50-Hour Service</p> <ol style="list-style-type: none">1. Perform the 25-hour service.2. Clean/replace the air cleaner's filter cartridge (paper filter) (shorter intervals for dusty operating conditions).3. Lubricate the front wheel bearings.4. Lubricate the steering control shafts.5. Lubricate the mower deck struts.6. Lubricate the cutting height adjuster.7. Check/adjust the parking brake.	

SERVICE JOURNAL

Action	Date, mtr reading, stamp, sign
<p>100-Hour Service</p> <ol style="list-style-type: none">1. Perform the 25-hour service.2. Perform the 50-hour service.3. Change engine oil.4. Check whether the hydraulic oil needs changing (every 300 hours).5. Check whether the engine oil filter needs changing (every 200 hours).6. Clean/replace the spark plugs.7. Replace the fuel filter.8. Clean the cooling fins on the engine and transmission.9. Clean and check the need to change the air filter's paper cartridge (every 200 hours).	

SERVICE JOURNAL

Action	Date, mtr reading, stamp, sign
<p>300-Hour Service</p> <ol style="list-style-type: none">1. Inspect the machine. Come to agreement with the customer as to which additional work is to be carried out.2. Perform the 25-hour service.3. Perform the 50-hour service.4. Perform the 100-hour service.5. Change the oil and filter in the hydraulic system.6. Clean the combustion chamber and grind the valve seats.7. Check the play in the engine valves.8. Replace the air cleaner's pre-filter (Oil-foam).	

SERVICE JOURNAL

Action	Date, mtr reading, stamp, sign
<p>At Least Once Each Year</p> <ol style="list-style-type: none">1. Clean the engine's cooling air intake (25 hours).2. Replace the air cleaner's pre-filter (Oil-foam) (300 hours).3. Replace the air filter's paper cartridge (200 hours).4. Change the engine oil (100 hours).5. Replace the engine oil filter (200 hours).6. Change the oil and filter in the hydraulic system (300 hours).7. Check/adjust the cutting height.8. Check/adjust the parking brake (50 hours).9. Clean/Change the spark plugs (100 hours).10. Change the fuel filter (100 hours).11. Clean the cooling fins (100 hours).12. Check the play in the engine valves (300 hours).13. Perform the 300-hour service at an authorized service workshop.	



114 00 87-26



2002W14