

Repair Parts Manual Manual De Repuestos

YTA22V46/96043021200

Please read the operator's manual carefully and make sure you understand the instructions before using the machine.

Por favor lea cuidadosamente y comprenda estas instrucciones antes de usar esta maquina.



English/Spanish



501 40 84-01

HOW TO USE THIS MANUAL

This manual is designed to provide the customer with a means to identify the parts on his/her tractor when ordering repair parts. The illustrations may or may not represent the actual assemblies; therefore, it is not recommended to use this manual as a guide to assemble or disassemble the tractor. Some hardware and parts are drawn larger in order to more readily identify them.

Each tractor has its own model number.

The model number for your tractor can be found on the fender under the seat.

When ordering parts, always give the following information:

- Product - "TRACTOR"
- MODEL NUMBER - "YTA22V46" (96043021200)"
- Part Number
- Part Description

TABLE OF CONTENTS

SCHEMATIC	3
ELECTRICAL.....	4-5
CHASSIS	6-7
DRIVE.....	8-9
ENGINE.....	10-11
STEERING	12-13
MOWER DECK.....	14-15
MOWER LIFT.....	16
SEAT	17
DECALS.....	18

COMO UTILIZAR ESTE MANUAL

Este manual está diseñado para brindarle al comprador un medio para identificar las piezas del tractor para cuando necesite hacer el pedido de un repuesto. Las ilustraciones pueden o no representar los ensambles reales; por lo tanto, no se recomienda utilizar este manual como una guía para ensamblar o desarmar el tractor. Algunos accesorios y piezas están dibujados en tamaños más grandes para identificarlos con mayor facilidad.

Cada tractor tiene su propio número de modelo.

El número de modelo del tractor se encuentra en el guardabarros debajo del asiento.

Cuando haga el pedido de una pieza, siempre brinde la siguiente información:

- Producto: "TRACTOR"
- NÚMERO DE MODELO: "YTA22V46" (96043021200)"
- Número de pieza
- Descripción de la pieza

ÍNDICE

DIAGRAMA.....	19
DIAGRAMA ELÉCTRICO	20-21
CHASIS.....	22-23
TRANSMISIÓN	24-25
MOTOR	26-27
DIRECCIÓN	28-29
PLATAFORMA DE LA CORTADORA DE CÉSPED.....	30-31
ELEVACIÓN DE LA CORTADORA DE CÉSPED.....	32
ASIENTO.....	33
CALCOMANÍAS.....	34

TRACTOR - MODEL NO. YTA22V46 (96043021200), PRODUCT NO. 960 43 02 12

SCHEMATIC

SCH11

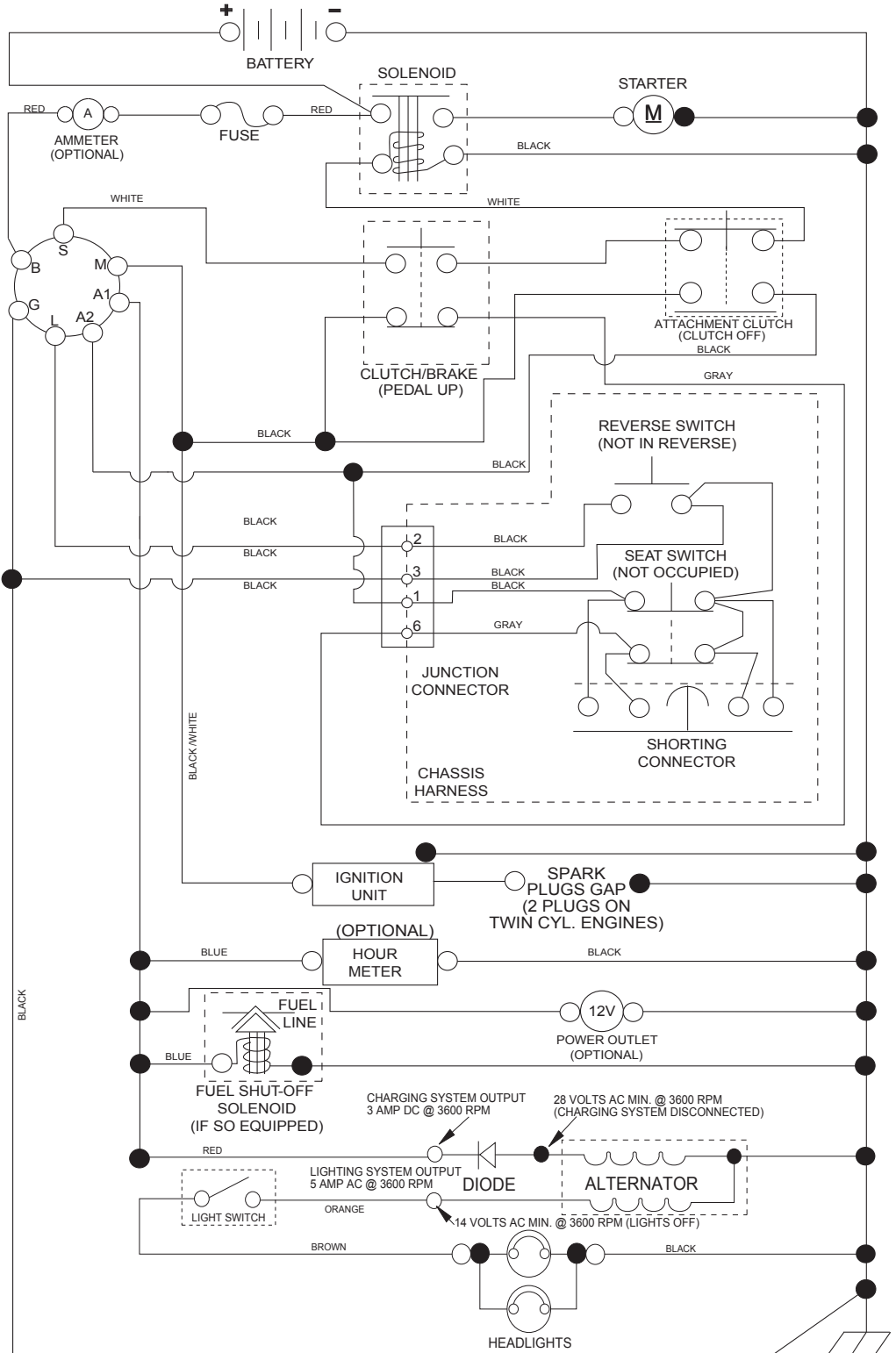

NOTE
YOUR TRACTOR IS EQUIPPED WITH A SPECIAL ALTERNATOR SYSTEM. THE LIGHTS ARE NOT CONNECTED TO THE BATTERY, BUT HAVE THEIR OWN ELECTRICAL SOURCE. BECAUSE OF THIS, THE BRIGHTNESS OF THE LIGHTS WILL CHANGE WITH ENGINE SPEED. AT IDLE THE LIGHTS WILL DIM. AS THE ENGINE IS SPEEDED UP, THE LIGHTS WILL BECOME THEIR BRIGHTEST.

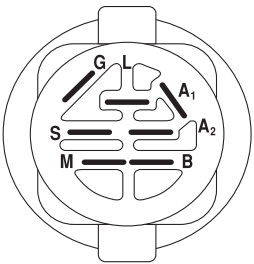

IGNITION SWITCH

POSITION	CIRCUIT	"MAKE"
OFF	M+G+A1	
RUN/OVERRIDE	B+A1	
RUN	B+A1	L+A2
START	B + S + A1	

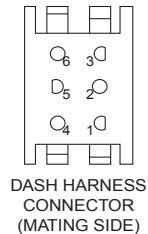
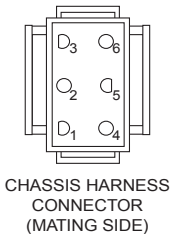

WIRING INSULATED CLIPS
NOTE: IF WIRING INSULATED CLIPS WERE REMOVED FOR SERVICING OF UNIT, THEY SHOULD BE RE-INSTALLED TO PROPERLY SECURE YOUR WIRING.

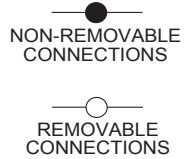

**TRACTOR - MODEL NO. YTA22V46 (96043021200), PRODUCT NO. 960 43 02 12
ELECTRICAL**

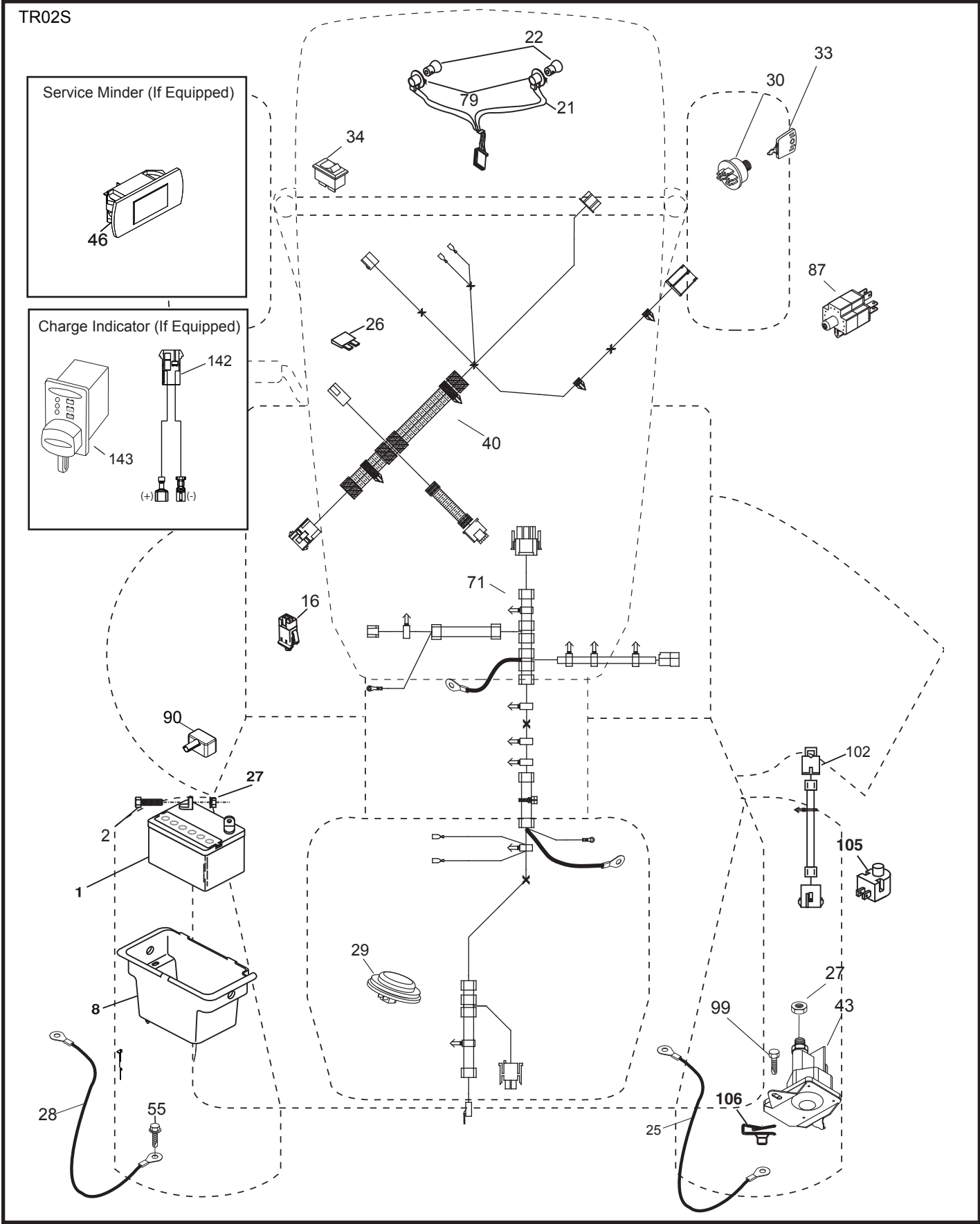

**TRACTOR - MODEL NO. YTA22V46 (96043021200), PRODUCT NO. 960 43 02 12
ELECTRICAL**

KEY NO.	PART NO.	DESCRIPTION
1	532 16 34-65	Battery
2	874 76 04-12	Bolt Hex Head 1/4-20 x 3/4
8	532 19 32-28	Box Battery
16	532 17 61-38	Switch Interlock Push-In
21	532 40 02-52	Harness Socket Light w/4152J
22	532 00 41-52	Bulb Light
25	581 49 80-01	Cable Starter
26	532 17 51-58	Fuse
27	873 51 04-00	Nut Keps Hex 1/4-20 unc
28	532 42 16-86	Cable, Ground
29	532 40 15-45	Switch, Seat
30	532 19 33-50	Switch, Ign
33	532 41 19-33	Key/Chain
34	532 11 07-12	Switch Light/Reset
40	581 02 31-01	Harness Ign. Dash
43	532 19 25-07	Solenoid
46	586 16 18-01	Gauge Serviceminder Hrmtr
55	817 06 05-12	Screw Thdrol 5/16-18 x 3/4 TYTT
71	581 02 30-01	Harness Ign. Chassis
79	532 17 52-42	Socket Asm. Bulb
87	532 19 78-02	Switch Interlock
90	532 43 53-95	Cover Terminal
99	817 67 04-12	Screw Hexwsh
102	581 02 34-01	Harness Pigtail
105	532 40 75-68	Switch Reverse
106	532 17 48-14	Pal Nut 1/4 Lugs

NOTE: All component dimensions given in U.S. inches
1 inch = 25.4 mm

TRACTOR - MODEL NO. YTA22V46 (96043021200), PRODUCT NO. 960 43 02 12
CHASSIS

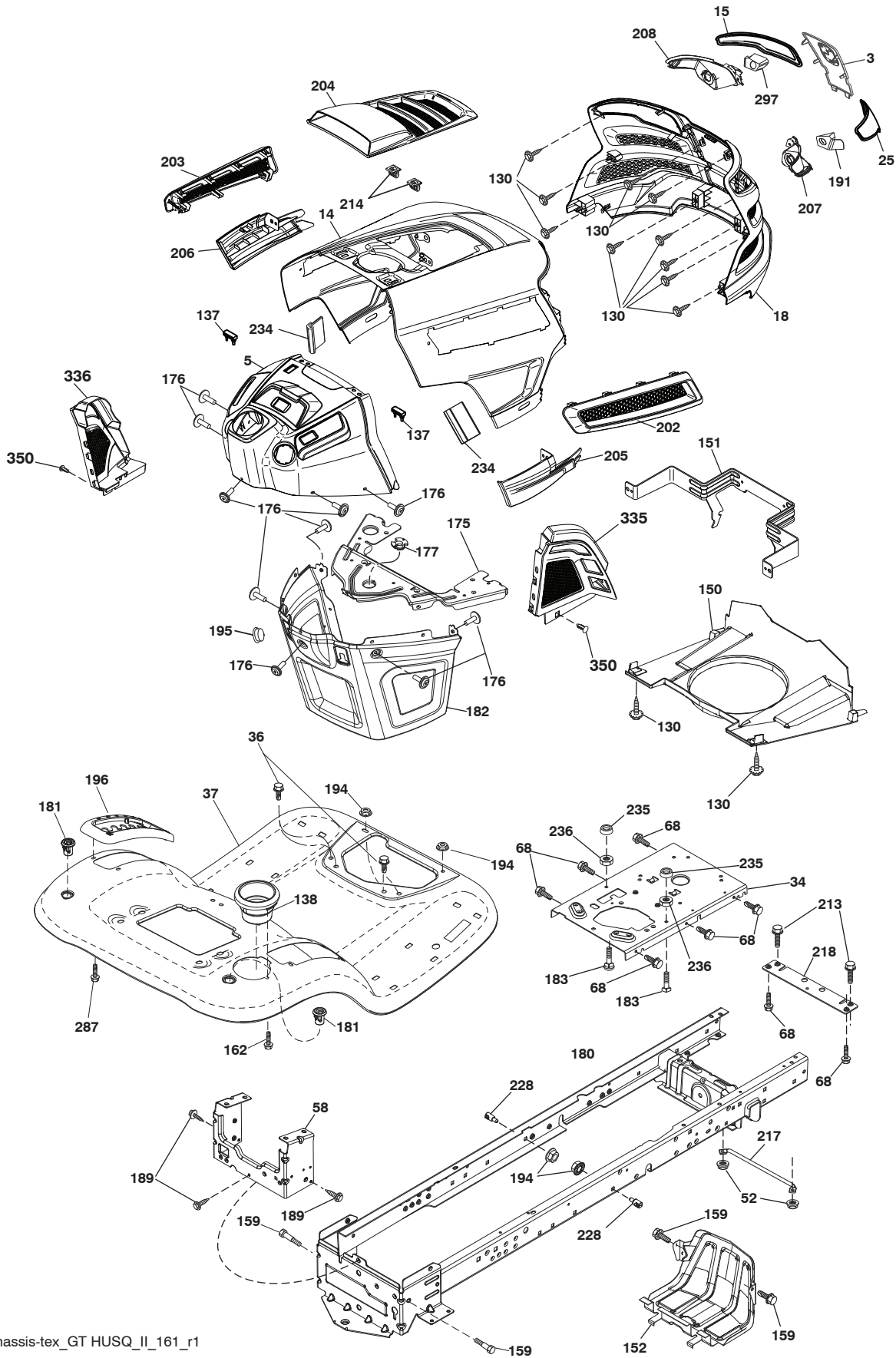

chassis-tex_GT HUSQ_II_161_r1

**TRACTOR - MODEL NO. YTA22V46 (96043021200), PRODUCT NO. 960 43 02 12
CHASSIS**

KEY NO.	PART NO.	DESCRIPTION	KEY NO.	PART NO.	DESCRIPTION
3	532 44 44-81	Applique Sub Asm.	194	873 90 05-00	Nut Lock Hex Flange 5/16-18
5	532 44 08-60	Dash	195	532 40 41-37	Plug Hole Dash Lower
14	532 44 11-77	Hood	196	532 43 96-47	Console Asm. Deck Lift
15	532 43 97-33	Lens LH	202	532 43 97-28	Vent Side Hood RH
18	532 44 06-53	Grille	203	532 43 97-27	Vent Side Hood LH
25	532 44 33-85	Lens RH	204	532 43 57-14	Vent Top Hood
34	580 91 08-01	Plate Engine	205	532 43 97-30	Trim Hood Side RH
36	817 06 05-12	Screw 5/16-18 x 3/4	206	532 43 97-29	Trim Hood Side LH
37	532 44 12-06	Fender	207	532 43 97-34	Bezel RH
52	873 68 05-00	Nut Lock 5/16-18	208	532 43 97-35	Bezel LH
58	532 41 22-80	Drawbar Upper	213	874 76 05-12	Bolt 5/16-18 x 3/4
68	817 49 05-08	Screw Thdrol 5/16-18 x 1/2	214	532 19 91-45	Clip Retainer Tinner
130	532 41 63-58	Screw #10 x 0.750	217	532 40 91-67	Rod Pivot
137	532 40 75-90	Bumper Dash	218	532 19 63-95	X-Piece Hood Stop
138	532 43 97-47	Cupholder	228	532 19 51-61	Stud Fastner
150	532 43 97-74	Air Duct	234	532 40 47-42	Bumper Hood
151	532 43 66-70	Bracket Pivot	235	532 40 61-29	Spacer Fender
152	532 43 98-70	Shield Browning	236	873 93 05-00	Nut Lock 5/16-18 unc
159	817 00 06-12	Screw Hexwsh Thrd 3/8-16 x 3/4	287	817 60 04-06	Screw 1/4-20 x 3/8
162	532 14 24-32	Screw	297	532 43 74-56	Insert Reflective LH
175	532 19 63-04	Crossmember	335	532 44 82-04	Cover RH
176	532 40 07-76	Screw 10-24 x 5/8	336	532 44 53-09	Cover LH
177	532 19 52-28	Bushing Steering	350	532 44 51-43	Clip X-mas Tree
180	532 41 50-63	Chassis			
181	532 43 97-46	Bushing Mtg. Fender Crgo			
182	532 40 68-59	Dash Lower			
183	874 52 05-20	Bolt 5/16-18 x 1-1/4			
189	817 00 05-12	Screw 5/16-18 x 3/4			
191	532 43 74-55	Insert Reflective RH			

NOTE: All component dimensions given in U.S. inches
1 inch = 25.4 mm

TRACTOR - MODEL NO. YTA22V46 (96043021200), PRODUCT NO. 960 43 02 12
DRIVE

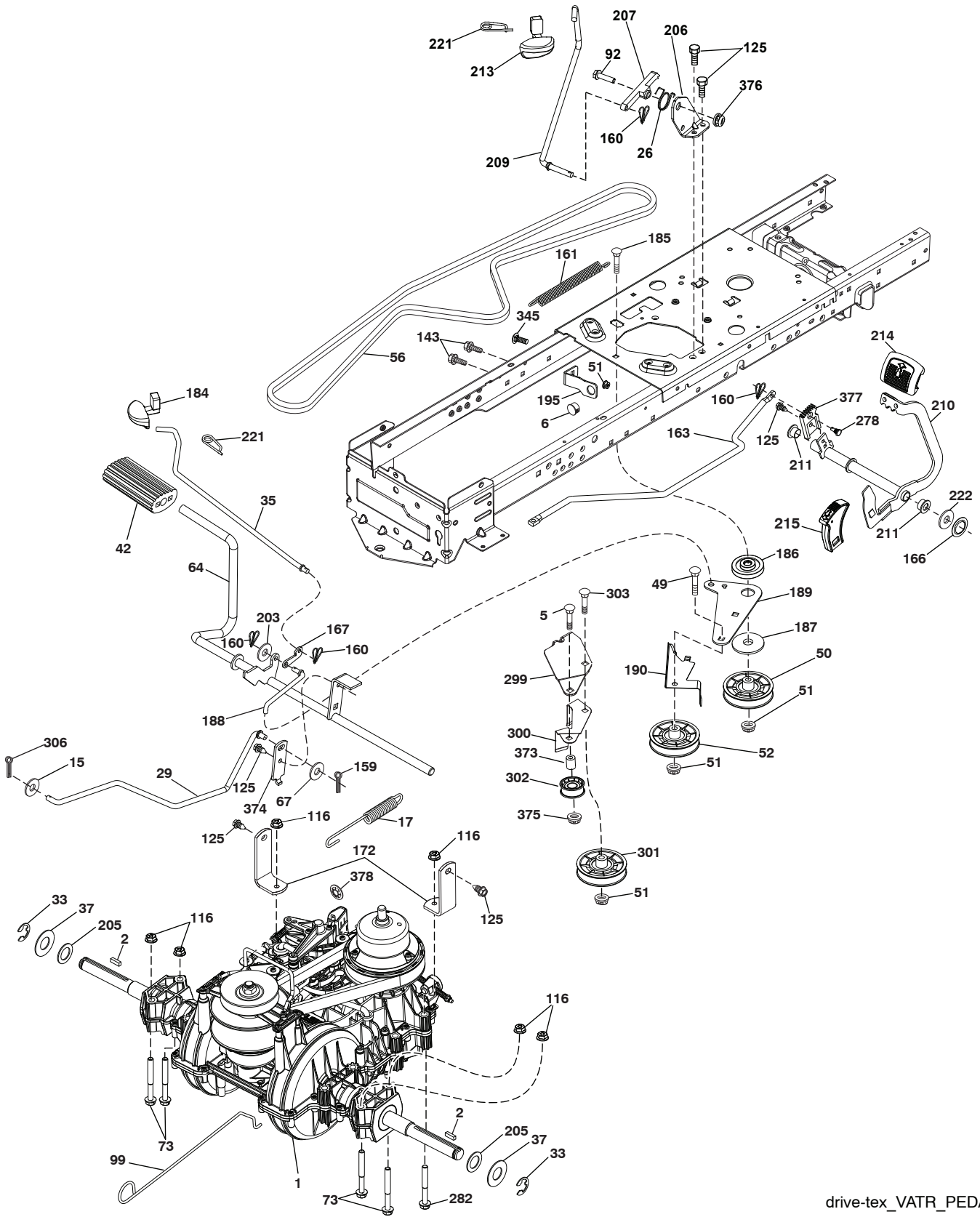

drive-tex_VATR_PEDAL_35

TRACTOR - MODEL NO. YTA22V46 (96043021200), PRODUCT NO. 960 43 02 12 DRIVE

KEY PART NO.	PART NO.	DESCRIPTION	KEY PART NO.	PART NO.	DESCRIPTION
1	---	Transaxle, Variator SD Pedal (584973901) (Order parts from transaxle manufacturer.)	188	532 19 43-23	Link Clutch Ground Drive
2	532 12 35-83	Key Square	189	532 19 43-17	Bellcrank Grounddrive Nstg/Nstl
5	874 76 06-36	Bolt Hex HS 3/8-16 unc	190	532 19 43-18	Keeper Bellcrank Drive Ground
6	532 12 40-28	Bushing Snap	195	581 50 46-01	Brake Bracket
15	819 13 13-16	Washer 13/32 x 13/16 x 16 Ga.	203	819 11 11-16	Washer 11/32 x 11/16 x 16 Ga.
17	584 95 40-01	Spring Brake	205	532 12 17-48	Washer 25/32 x 1-5/8 x 16 Ga.
26	532 19 96-79	Spring Return Cruise	206	532 44 85-96	Bracket Mount Latch Cruise
29	584 82 31-01	Rod Brake	207	532 44 82-64	Latch Control Cruise
33	812 00 00-01	E-Ring	209	532 19 95-92	Rod Control Cruise
35	583 86 45-01	Rod Brake Parking	210	532 44 82-70	Weldment Pedal
37	532 18 89-67	Washer Harden .793 x 1.637 x 060	211	532 12 01-83	Bearing Nylon
42	532 12 48-72	Cover Pedal Blk Round	213	532 40 31-19	Knob Control Cruise
49	872 11 06-14	Bolt Rdhd 3/8-16unc x1-3/4 Gr.5	214	532 42 12-63	Pedal Forward Pad
50	532 19 43-27	Idler.Flat	215	532 44 82-54	Cap Pedal Reverse
51	873 90 06-00	Nut Hex Flangelock 3/8-16	221	532 40 31-87	Retainer Spring Clip Handle
52	532 19 43-26	Idler V-Groove Offset	222	879 21 20-10	Washer 21/32 x 1-1/4 10 Ga.
56	532 19 72-53	Belt Drive	278	580 36 91-01	Bolt Cruise Variator
64	532 44 83-53	Shaft Asm. Pedal Brake	282	874 49 05-48	Screw Thdrol 5/16-18 x 3
67	819 13 13-12	Washer 13/32 x 13/16 x 12 Ga.	298	532 41 56-83	Bracket Mount Idler
73	874 49 05-44	Bolt Hex Flghd 5/16-18 Gr. 5	300	532 41 56-81	Keeper Idler Rear
92	874 76 05-20	Bolt	301	532 41 56-80	Pulley Idler V-Groove
99	532 43 59-35	Rod Bypass	302	581 42 05-01	Pulley Idler Flat 2.0 Od
116	873 90 05-00	Nut Lock Hex Flange 5/16-18 unc	303	872 11 06-18	Bolt Rdhd Sgnk 3/8-16 x 2-1/4
125	817 00 05-12	Screw 5/16-18 x 3/4 Smgml Tap/Bl	306	876 02 04-16	Pin Cotter 1/8 x 1
143	817 49 05-08	Screw Thdrol 5/16-18 x 1/2 Tytt	345	872 11 06-06	Bolt Rdhd Sgnk 3/8-16 x 1 Gr. 5
159	876 02 04-12	Pin Cotter 1/8 x 3/4	373	581 46 18-01	Spacer Idler
160	532 16 94-84	Retainer Clip(M) Dia. 290	374	581 47 52-01	Bracket Brake Arm
161	532 10 57-09	Spring Return Clutch 6.75	375	873 68 06-00	Nut Crownlock 3/8-16 unc
163	587 84 79-02	Rod Control Pedal	376	532 42 65-89	Nut Flange
166	532 42 91-64	Nut Push .625	377	584 30 34-01	Gear Sector
167	532 40 52-57	Latch Brake Parking	378	584 28 77-01	Nut Push 8 mm
172	583 97 42-01	Strap Torque LH/RH			
184	587 65 37-01	Handle Parking Brake			
185	872 11 06-22	Bolt Rdhd 3/8-16 unc x 2-3/4 Gr.5			
186	532 19 43-21	Spacer Retainer			
187	819 13 32-10	Washer 13/32 x 2 x 10 Ga.			

NOTE: All component dimensions given in U.S. inches
1 inch = 25.4 mm

**TRACTOR - MODEL NO. YTA22V46 (96043021200), PRODUCT NO. 960 43 02 12
ENGINE**

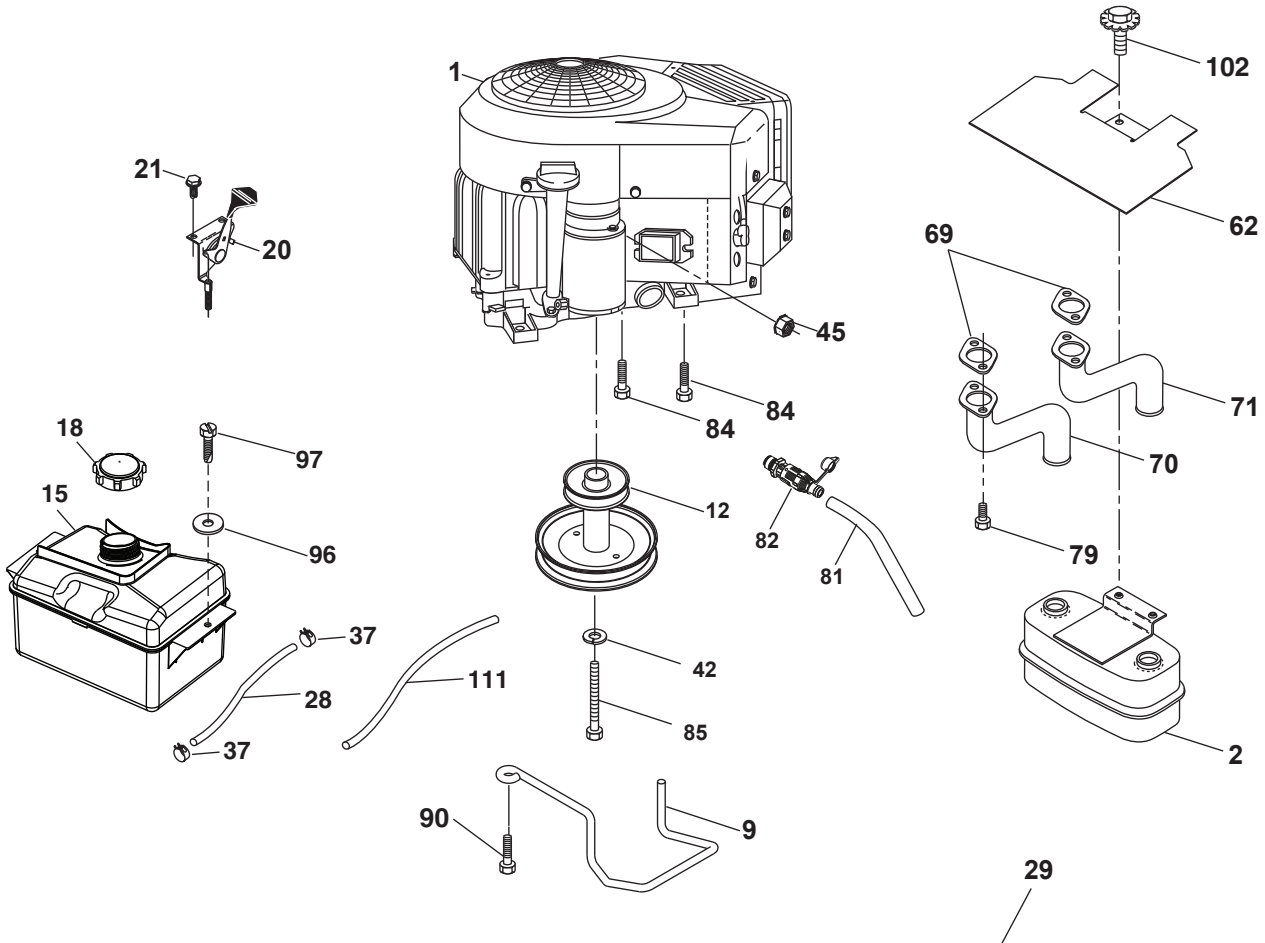

engine-tex_bs-2cyl_71_r1

SPARK ARRESTER KIT

TRACTOR - MODEL NO. YTA22V46 (96043021200), PRODUCT NO. 960 43 02 12 ENGINE

KEY NO.	PART NO.	DESCRIPTION
1	— — — — —	Engine B&S Model No.44N677-0005-G1 (587639101)(Order parts from engine manufacturer.)
2	532 44 59-62	Muffler
9	584 91 16-01	Keeper Belt Engine
12	532 40 51-40	Pulley Engine
15	532 43 30-07	Tank Fuel
18	581 17 61-01	Cap Fuel
20	532 42 35-02	Control Throttle/Choke
21	532 41 63-58	Screw #10 x 0.750 BOS Thread
28	532 40 11-37	Fuel Line
29	532 13 71-80	Spark Arrester Kit
37	532 12 34-87	Clamp Hose
42	810 04 07-00	Washer Lock 7/16
45	873 51 04-00	Nut Keps Hex 1/4-20 unc
62	532 43 40-17	Shield Heat Muffler
69	532 16 53-91	Gasket
70	581 88 11-01	Exhaust Tube LH
71	581 88 10-01	Exhaust Tube RH
79	532 18 39-06	Screw Socket HD 5/16-18 x 1
81	532 14 84-56	Tube Drain Oil Easy
82	532 42 82-87	Valve Drain Oil
84	817 06 06-20	Screw 3/8-16 x 1-1/4
85	532 17 39-37	Bolt 7/16-20 x 4 x Gr. 5-1.5
90	817 00 06-16	Screw 3/8-16 x 1
96	819 09 14-16	Washer 9/32 x 7/8 x 16
97	817 67 04-12	Screw 1/4-20 x 3/4
102	817 00 05-12	Screw 5/16-18 x 3/4
111	532 41 41-19	Purge Line

NOTE: All component dimensions given in U.S. inches
1 inch = 25.4 mm

For engine service and replacement parts, call the toll free number for your engine manufacturer listed below:

Briggs & Stratton 1-800-233-3723

Engine Power Rating Information

The gross power rating for individual gas engine models is labeled in accordance with SAE (Society of Automotive Engineers) code J1940 (Small Engine Power & Torque Rating Procedure), and rating performance has been obtained and corrected in accordance with SAE J1995 (Revision 2002-05). Torque values are derived at 3060 RPM; horsepower values are derived at 3600 RPM. Actual gross engine power will be lower and is affected by, among other things, ambient operating conditions and engine-to-engine variability. Given both the wide array of products on which engines are placed and the variety of environmental issues applicable to operating the equipment, the gas engine will not develop the rated gross power when used in a given piece of power equipment (actual “on-site” or net power). This difference is due to a variety of factors including, but not limited to, accessories (air cleaner, exhaust, charging, cooling, carburetor, fuel pump, etc.), application limitations, ambient operating conditions (temperature, humidity, altitude), and engine-to-engine variability. Due to manufacturing and capacity limitations, Briggs & Stratton may substitute an engine of higher rated power for this Series engine.

TRACTOR - MODEL NO. YTA22V46 (96043021200), PRODUCT NO. 960 43 02 12
STEERING ASSEMBLY

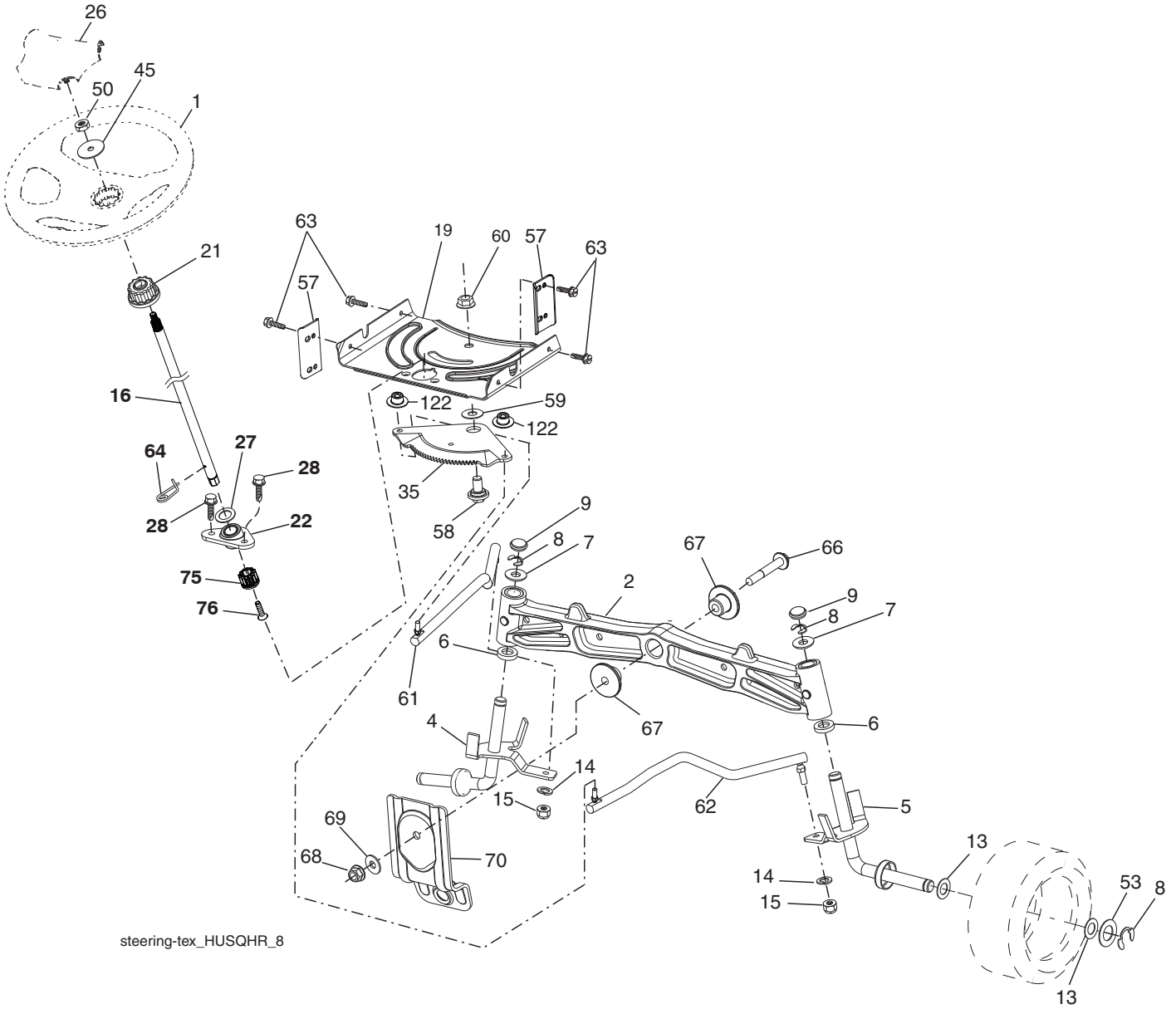

steering-tex_HUSQHR_8

**TRACTOR - MODEL NO. YTA22V46 (96043021200), PRODUCT NO. 960 43 02 12
STEERING ASSEMBLY**

KEY NO.	PART NO.	DESCRIPTION
1	532 43 97-40	Wheel, Steering
2	532 19 59-68	Axle Cast Iron
4	532 40 30-87	Spindle Asm., LH
5	532 40 30-88	Spindle Asm., RH
6	532 12 49-31	Washer, Thrust
7	532 12 17-48	Washer 25/32 x 1-5/8 x 16 Ga.
8	812 00 00-29	Ring, Klip #T5304-75
9	532 12 12-32	Cap, Spindle
13	532 12 17-49	Washer 25/32 x 1-1/4 x 16 Ga.
14	810 04 06-00	Washer, Lock Hvy Hlcl Spr 3/8
15	873 54 06-00	Nut, Crown Lock 3/8-24 unf
16	587 01 60-02	Steering Shaft
19	532 19 47-29	Plate Steering
21	586 84 02-01	Adapter Wheel Steering
22	585 02 98-02	Bearing
26	532 43 97-43	Insert, Wheel Steering
27	819 21 16-16	Washer
28	817 00 06-12	Screw 3/8-16 x 3/4
35	532 19 47-32	Gear, Sector Plate
45	587 01 64-01	Washer 3/8 ID 2-3/8 OD 12 Ga. PLTD
50	873 90 06-00	Nut Lock Flg 3/8-16 unc
53	532 18 89-67	Washer Hardened .793 x 1.637 x .060
57	532 40 74-65	Bracket Upstop
58	532 19 47-47	Bolt Shoulder Sector Pivot CFM
59	532 19 47-48	Washer Thrust Sector Steering
60	873 97 10-00	Nut Flange Lock 5/8-11
61	532 19 47-40	Draglink, LH
62	532 19 47-41	Draglink, RH
63	817 00 05-12	Screw 5/16-18 x 3/4
64	532 19 98-49	Retainer Clip Spring Steering
66	871 02 07-48	Bolt Hex Fghd 7/16-14 x 3 Serr
67	532 19 47-37	Bushing PM Front Axle
68	873 90 07-00	Nut Lock Flange 7/16-14 Gr. 5
69	532 19 91-62	Washer 1.5 x .505 x .118
70	585 33 88-01	Bracket Deck Susp. Front
75	580 68 37-01	Pinion
76	580 68 36-01	Screw Head Sock
122	532 44 49-62	Cap Gear

NOTE: All component dimensions given in U.S. inches
1 inch = 25.4 mm

TRACTOR - MODEL NO. YTA22V46 (96043021200), PRODUCT NO. 960 43 02 12
MOWER DECK

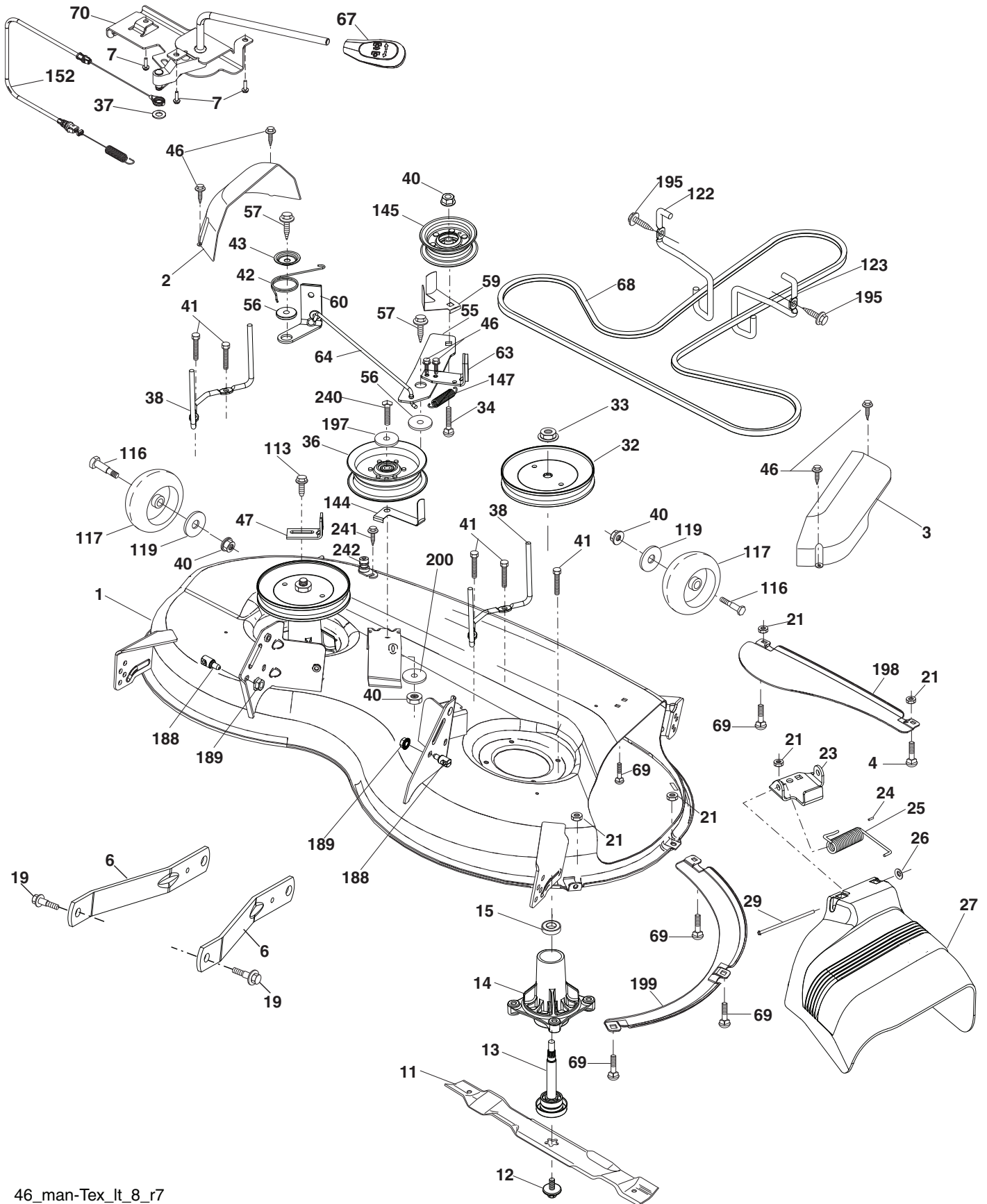

46_man-Tex_lt_8_r7

**TRACTOR - MODEL NO. YTA22V46 (96043021200), PRODUCT NO. 960 43 02 12
MOWER DECK**

KEY PART NO. NO.	DESCRIPTION	KEY PART NO. NO.	DESCRIPTION		
1	586 29 31-01	Mower Housing	63	532 19 94-77	Arm Brake Mower
2	532 40 55-06	Cover Mandrel RH	64	532 40 51-38	Linkage Brake
3	532 40 55-07	Cover Mandrel LH	67	532 40 30-12	Handle, Clutch Cable
4	874 76 05-12	Bolt Hex HD. 5/16-18	68	532 40 51-43	V-Belt
6	532 19 51-86	Arm Suspension	69	872 14 05-05	Bolt
7	532 41 63-58	Screw # 10 x 0.750	70	532 19 99-72	Clutch Asm. Cable
11	532 40 53-80	Blade Mower Hi Lift	113	817 00 05-10	Screw 5/16-18
12	584 30 93-01	Screw Sems 7/16-20 x 1 Hx Hd	116	532 19 34-06	Bolt, Shoulder
13	532 19 28-72	Shaft Assembly, Mandrel	117	532 17 48-73	Wheel, Gauge
14	532 18 72-81	Housing, Mandrel	119	819 13 20-12	Washer 13/32 x 1-1/4 x 12 Ga.
15	532 11 04-85	Bearing, Ball, Mandrel	122	532 19 72-58	Keeper Belt Eng. LH
19	532 19 65-39	Bolt, Shoulder	123	532 19 72-59	Keeper Belt Eng. RH
21	873 68 05-00	Nut	144	532 19 92-04	Keeper Belt
23	532 19 25-57	Bracket, Deflector	145	532 19 31-97	Pulley Idler
24	532 10 53-04	Cap, Sleeve	147	532 40 18-72	Spring Return
25	532 19 70-26	Spring, Torsion, Deflector	152	584 24 35-01	Cable Clutch Manual w/Spr.
26	532 11 04-52	Nut, Push	188	532 19 51-61	Stud Fastener
27	532 40 53-57	Shield, Deflector	189	873 90 05-00	Nut Lock Hex Flange
29	532 13 14-91	Rod, Hinge	195	817 00 06-12	Screw 3/8-16 x 3/4
32	532 19 74-73	Pulley, Mandrel	197	819 13 13-12	Washer 13/32 x 13/16 x 12 Ga.
33	532 40 02-34	Nut, Toplock, Flanged	198	532 40 31-49	Baffle Center Front
34	872 11 06-12	Bolt Carr Sh. 3/8-16 x 1-1/2 Gr. 5	199	532 40 31-50	Baffle Front RH
36	532 19 73-79	Pulley, Idler, Flat	200	532 41 35-24	Washer 13/32 x 1 x 1/2 11 Ga.
37	819 13 13-16	Washer 13/32 x 13/16 x 16 Ga.	240	874 52 06-36	Bolt 3/8-16 unc x 2-1/4 Gr. 5
38	532 43 25-20	Keeper Belt LH Mandrel	241	532 15 29-27	Screw
40	873 90 06-00	Nut, Lock Flg. 3/8-16 unc	242	532 41 55-98	Washout Port
41	584 95 39-01	Box Hex Washer Head 3/16-18 x 1.19	--	532 41 64-05	Quick Connect Coupling
42	532 19 84-10	Spring Torsion Brake	--	587 25 33-01	Mandrel Assembly (Includes housing (key #14), shaft assembly (key #13), and bearing (key #15) only - pulley/nut/washer and blade bolt/washers not included)
43	532 19 72-56	Spring Torsion Retainer	--	532 43 18-23	Replacement Mower, Complete
46	532 13 77-29	Screw			
47	532 19 72-50	Bracket Clutch Cable			
55	532 19 72-49	Arm, Idler			
56	532 19 90-92	Spacer, Retainer			
57	817 00 06-16	Screw Hexwsh Thd 3/8-16 x 1			
59	532 14 10-43	Guard, Tuv Idler (94)			
60	532 19 94-71	Arm Brake Mower LH			

NOTE: All component dimensions given in U.S. inches
1 inch = 25.4 mm

**TRACTOR - MODEL NO. YTA22V46 (96043021200), PRODUCT NO. 960 43 02 12
MOWER LIFT**

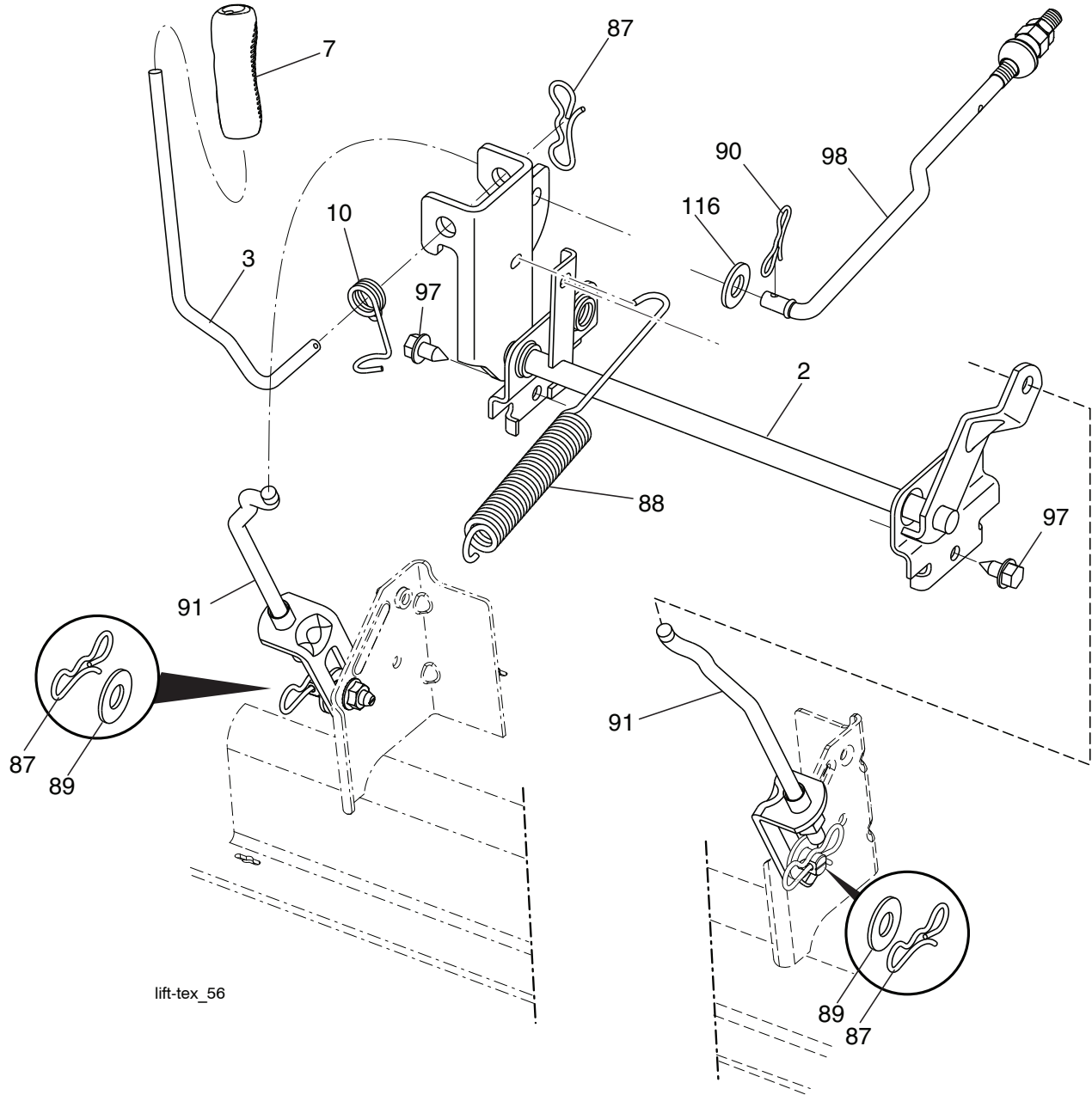

KEY NO.	PART NO.	DESCRIPTION
2	532 42 20-27	Shaft Asm., Lift
3	532 19 52-31	Lever Asm., Lift RH
7	580 96 23-01	Grip, Lever
10	532 19 63-14	Spring Torsion
87	532 19 42-09	Pin Cotter 7/16 Bow Tie Lock
88	532 41 07-10	Spring Lift Assist
89	819 19 19-12	Washer Clear Zinc
90	532 19 42-08	Pin Cotter 5/16 Bow Tie Lock
91	532 19 79-84	Link Lift Susp Mower Rear

KEY NO.	PART NO.	DESCRIPTION
97	817 00 06-12	Screw 3/8-16 x .75 Smsgml Tap/R.Z
98	532 42 05-25	Link Lift Susp. Front Mower
116	819 15 15-16	Washer 15/32 x 15/16 x 16 Ga.

NOTE: All component dimensions given in U.S. inches
1 inch = 25.4 mm

**TRACTOR - MODEL NO. YTA22V46 (96043021200), PRODUCT NO. 960 43 02 12
SEAT ASSEMBLY**

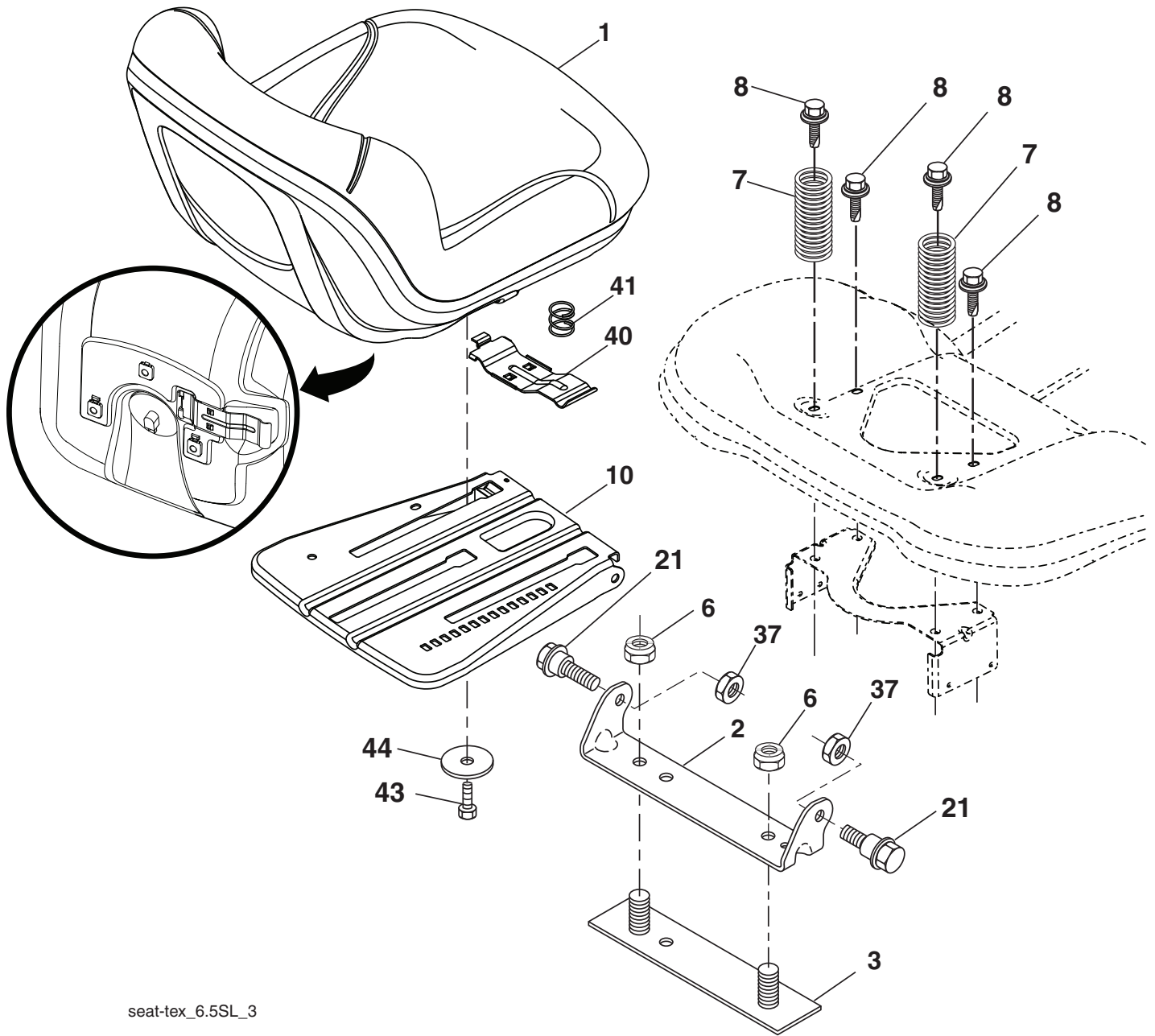

seat-tex_6.5SL_3

KEY NO.	PART NO.	DESCRIPTION
1	532 43 98-22	Seat
2	532 18 01-66	Bracket Pivot Fender
3	532 14 06-75	Strap, Asm Fender
6	873 80 06-00	Nut, Lock w/Ins. 3/8-16 unc
7	587 61 33-01	Spring, Seat Cprsn
8	532 17 18-77	Bolt 5/16-18 unc x 3/4 w/Sems
10	532 19 69-77	Pan, Seat
21	587 90 78-01	Bolt, Shoulder 5/16-18 x 5/8

KEY NO.	PART NO.	DESCRIPTION
37	873 80 05-00	Nut, Lock 5/16-18 unc
40	532 43 98-71	Handle Slide Seat
41	532 19 82-00	Spring Latch Seat
43	874 76 06-12	Bolt Fin Hex 3/8-16 unc x 3/4
44	819 13 38-12	Washer 13/32 x 2-3/8 x 12 Ga.

NOTE: All component dimensions given in U.S. inches
1 inch = 25.4 mm

**TRACTOR - MODEL NO. YTA22V46 (96043021200), PRODUCT NO. 960 43 02 12
DECALS**

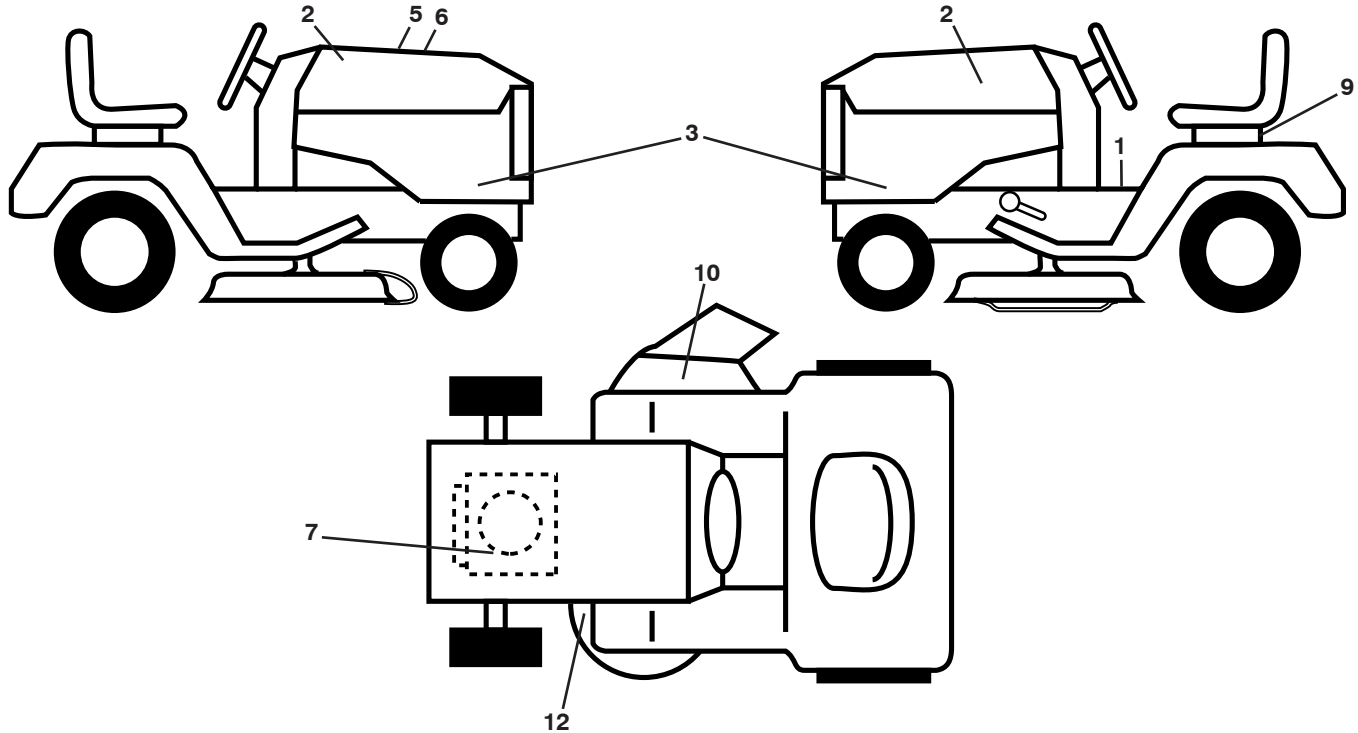

KEY NO.	PART NO.	DESCRIPTION
1	581 57 89-01	Decal, Fender Warning
2	581 62 73-01	Decal, Hood
3	501 20 38-01	Decal, Hood Panel SD
5	532 42 38-29	Decal, Customer Respons.
6	501 30 21-01	Decal, Replacement
7	585 55 69-01	Decal, Engine B&S
9	532 14 50-05	Decal, Battery Dnge/Poi
10	584 90 46-01	Decal, Deflect. Warning
12	581 58 00-01	Decal, Mower V-Belt Schematic

KEY NO.	PART NO.	DESCRIPTION
--	581 72 48-01	Decal, Bypass
--	532 43 96-81	Pad, Footrest, LH
--	532 43 96-82	Pad, Footrest, RH
--	115 77 70-26	Manual, Operators (English/Spanish)
--	501 40 84-01	Manual, Parts (English/Spanish)
--	587 71 00-26	Manual, Quick Start Guide (English/Spanish)

WHEELS AND TIRES

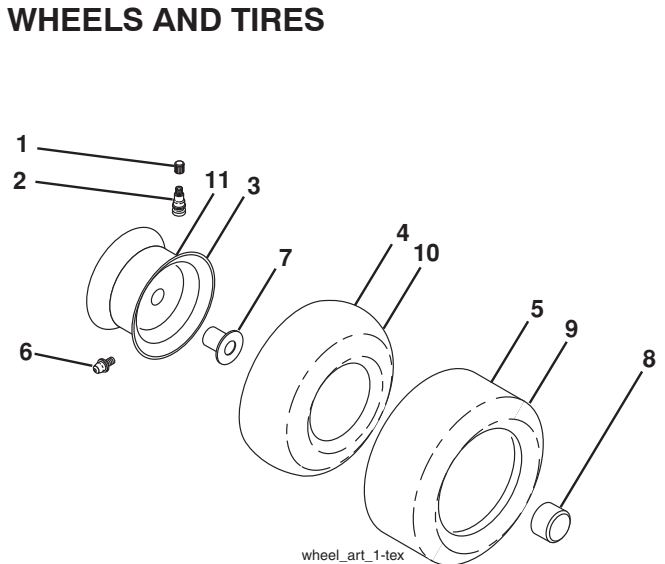

KEY NO.	PART NO.	DESCRIPTION
1	532 05 91-92	Cap Valve Tire
2	532 06 51-39	Stem Valve
3	532 13 83-36	Rim Front
4	532 05 99-04	Tube Front (Service Item Only)
5	532 10 62-22	Tire Front 15 x 6-6
6	532 12 49-57	Fitting Grease (Front Wheel Only)
7	532 12 49-59	Bearing Flange (Front Wheel Only)
8	532 17 50-39	Cap Axle Blk 1 50 x 1 00
9	532 13 84-68	Tire Rear 20 x 8-8
10	532 12 49-26	Tube Rear (Service Item Only)
11	532 13 83-37	Rim Asm 8" Rear
--	532 14 43-34	Sealant, Tire (10 oz. Tube)

NOTE: All component dimensions given in U.S. inches
1 inch = 25.4 mm

TRACTOR - MODELO NO. YTA22V46 (96043021200), PRODUCTO NO. 960 43 02 12

DIAGRAMA

SCH11-s

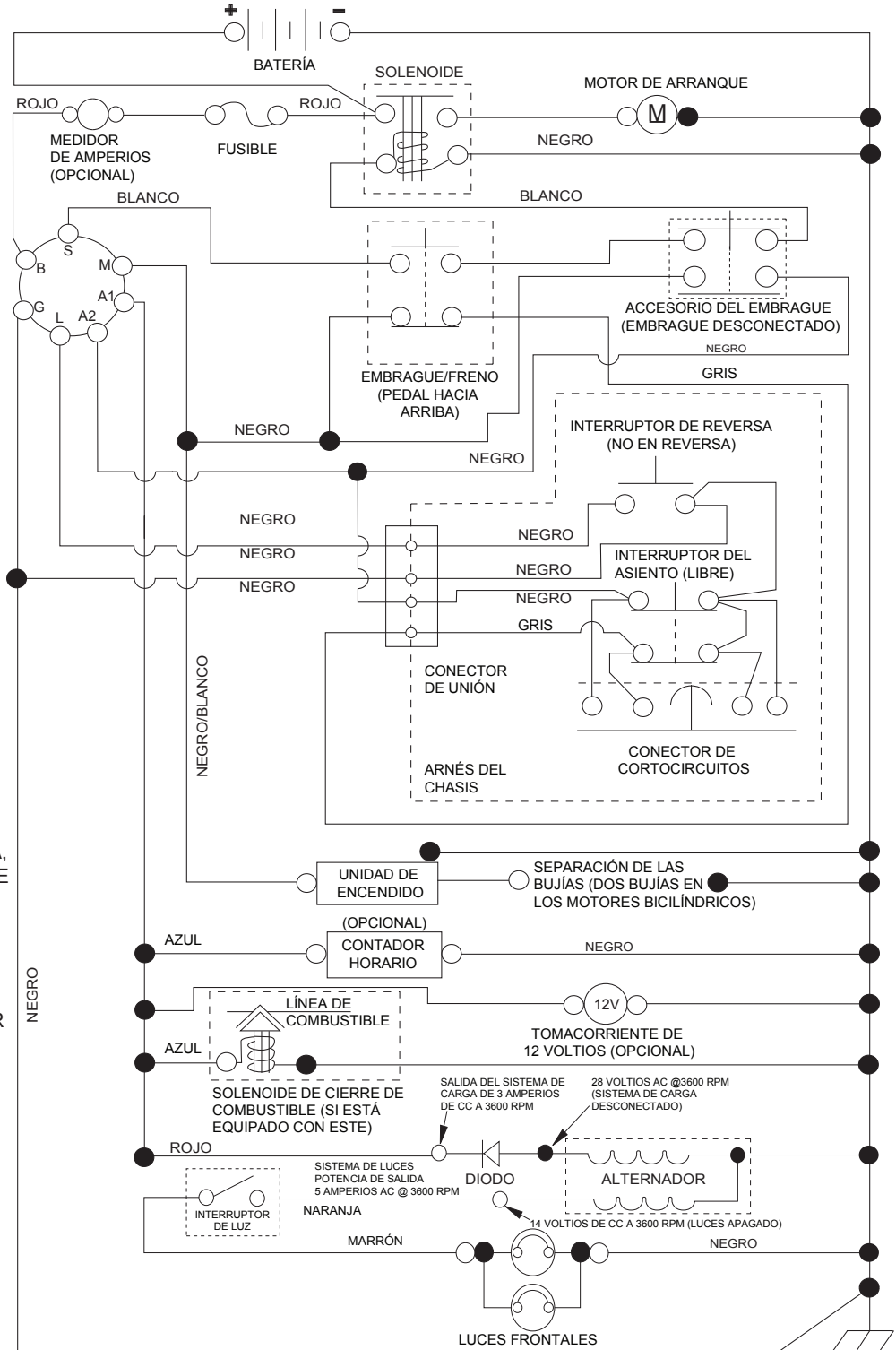

NOTAS:
 QUE SU TRACTOR ES EQUIPADO CON UN SISTEMA ESPECIAL DE ALTERNADOR. LAS LUCES NO SON CONECTADAS A LA BATERIA, PERO TIENEN SU PROPIA FUENTE ELECTRICA. A CAUSA DE ESTO, EL BRILLO DE LAS LUCES CAMBIARA CON LA VELOCIDAD DE MOTOR. EN LENTO, LAS LUCES NO SON COMO BRILLANTES. CUANDO EL MOTOR ES ACELERADO, LA LUZ CONSEGUIRÁ MÁS BRILLANTE.

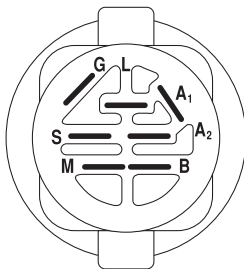

INTERRUPTOR DE ENCENDIDO

POSICIÓN	CIRCUITO «MARCA»
APAGADO	M+G+A1
PONER EN FUNCIONAMIENTO/ANULAR	B+A1
PONER EN FUNCIONAMIENTO	B+A1 L+A2
ARRANCAR	B + S + A1

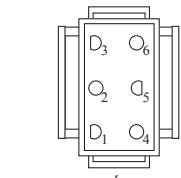

CONEXIÓN DEL ARNÉS DEL CHASIS (LATERAL QUE COINCIDA)

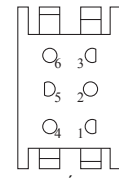

CONEXIÓN PARA EL ARNÉS DEL TABLERO (LATERAL QUE COINCIDA)

NOTA SOBRE LAS ABRAZADERAS DE AISLAMIENTO DEL CABLEADO: SI SE QUITAN LAS ABRAZADERAS DE AISLAMIENTO DEL CABLEADO PARA HACER EL MANTENIMIENTO DE LA UNIDAD, SE LAS DEBERÁ INSTALAR NUEVAMENTE PARA PROTEGER EL CABLEADO ADECUADAMENTE.

● CONEXIONES NO DESMONTABLES

○ CONEXIONES DESMONTABLES

TRACTOR - MODELO NO. YTA22V46 (96043021200), PRODUCTO NO. 960 43 02 12
DIAGRAMA ELÉCTRICO

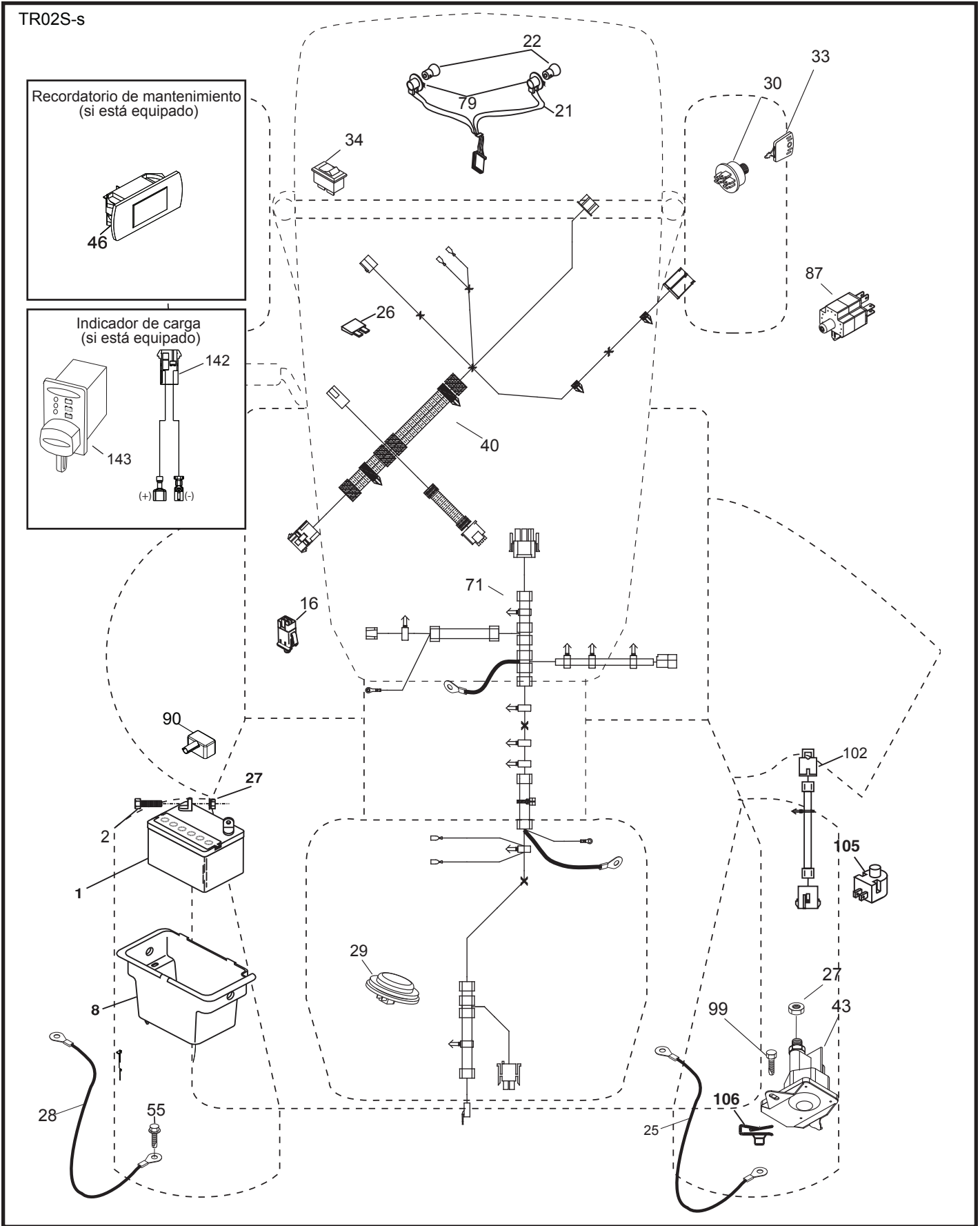

**TRACTOR - MODELO NO. YTA22V46 (96043021200), PRODUCTO NO. 960 43 02 12
DIAGRAMA ELÉCTRICO**

CÓDIGO PIEZA		DESCRIPCIÓN
No.	No.	
1	532 16 34-65	Batería
2	874 76 04-12	Perno de cabeza hexagonal de 1/4-20 x 3/4
8	532 19 32-28	Caja de la batería
16	532 17 61-38	Interruptor corta corriente a presión
21	532 40 02-52	Cableado del enchufe para la luz c/4152J
22	532 00 41-52	Bombilla de luz
25	581 49 80-01	Cable
26	532 17 51-58	Fusible
27	873 51 04-00	Tuerca hexagonal Keps de 1/4-20 unc
28	532 42 16-86	Cable a tierra
29	532 40 15-45	Interruptor del asiento
30	532 19 33-50	Interruptor de encendido
33	532 41 19-33	Llave/cadena
34	532 11 07-12	Interruptor de luz/de restauración
40	581 02 31-01	Cableado del tablero de encendido
43	532 19 25-07	Solenoide
46	586 16 18-01	Indicador SRVCMNDR HRMTR
55	817 06 05-12	Tornillo de 5/16-18 x 3/4
71	581 02 30-01	Cableado de encendido
79	532 17 52-42	Enchufe de cierre por torsión del ensamble de la bombilla
87	532 19 78-02	Interruptor corta corriente del cable de embrague
90	532 43 53-95	Tapa de los bornes de la batería
99	517 67 04-12	Tornillo
102	581 02 34-01	Cableado
105	532 40 75-68	Interruptor
106	532 17 48-14	Tuerca 1/4

NOTA: Las dimensiones de todos los componentes están expresadas en pulgadas americanas. 1 pulgada = 25,4 mm

TRACTOR - MODELO NO. YTA22V46 (96043021200), PRODUCTO NO. 960 43 02 12
 CHASIS

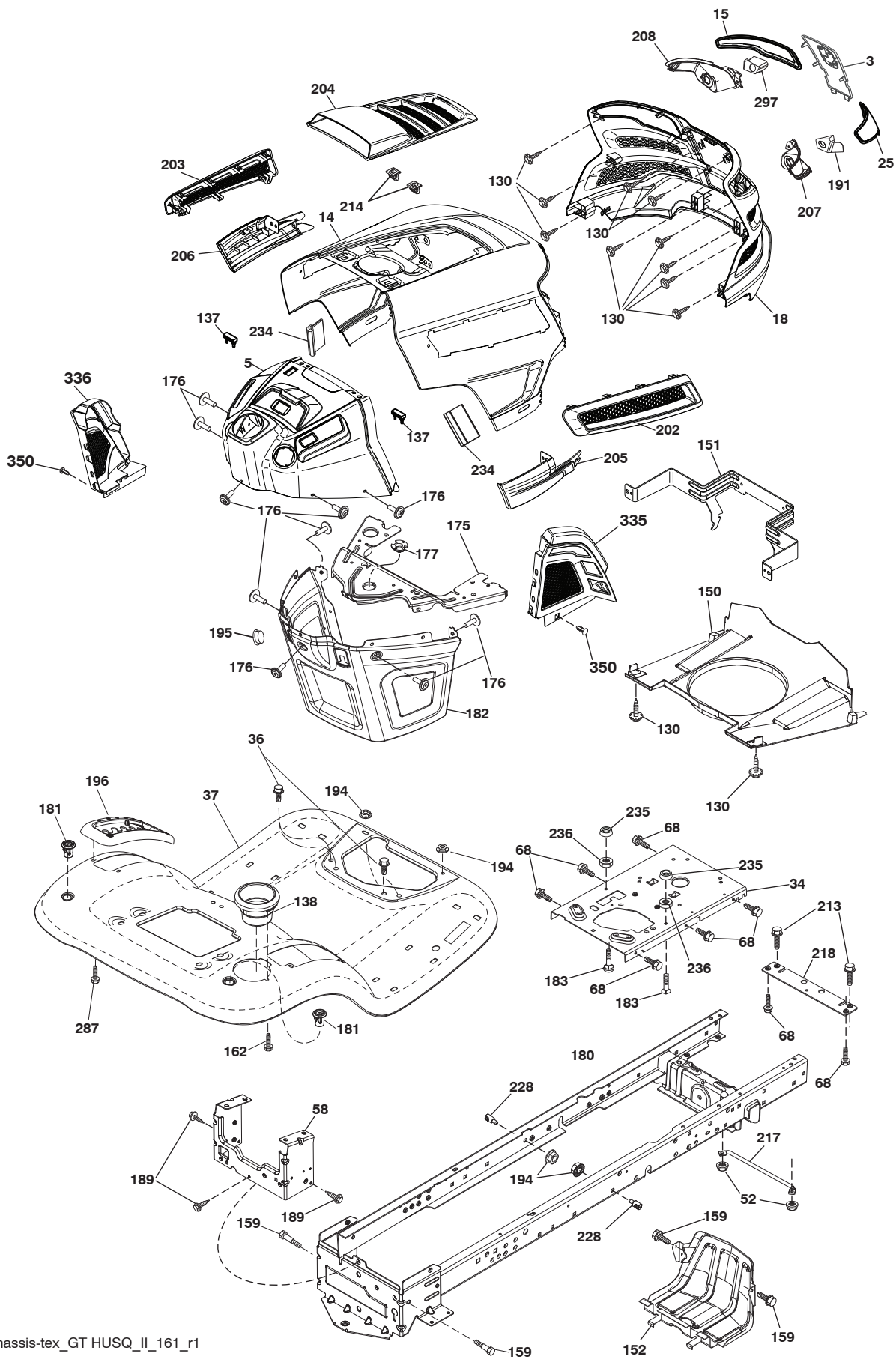

TRACTOR - MODELO NO. YTA22V46 (96043021200), PRODUCTO NO. 960 43 02 12 CHASIS

CÓDIGO PIEZA		DESCRIPCIÓN	CÓDIGO PIEZA		DESCRIPCIÓN
No.	No.		No.	No.	
3	532 44 44-81	Aplica Submontaje	194	873 90 05-00	Tuerca de presión de 5/16-18
5	532 44 08-60	Tablero	195	532 40 41-37	Tapón
14	532 44 11-77	Capota	196	532 43 96-47	Ensamble de la consola de la plataforma de elevación
15	532 43 97-33	Lente izquierdo de la parrilla	202	532 43 97-28	Salida de Ventilación (LD)
18	532 44 06-53	Parrilla	203	532 43 97-27	Salida de Ventilación (LI)
25	532 44 33-85	Lente derecho de la parrilla	204	532 43 57-14	Salida de Ventilación superior
34	580 91 08-01	Chapa Motor	205	532 43 97-30	Camisa de Capota (LD)
36	817 06 05-12	Tornillo de 5/16-18 x 3/4	206	532 43 97-29	Camisa de Capota (LI)
37	532 44 12-06	Guardabarros	207	532 43 97-34	Bisel derecho
52	873 68 05-00	Tuerca de presión 5/16-18	208	532 43 97-35	Bisel izquierdo
58	532 41 22-80	Barra de tracción	213	874 76 05-12	Perno
68	817 49 05-08	Tornillo de 5/16-18 x 1/2	214	532 19 91-45	Cierre
130	532 41 63-58	Tornillo No. 10 x 0,75	217	532 40 91-67	Varilla giratoria
137	532 40 75-90	Cubierta Tablero	218	532 19 63-95	Tope
138	532 43 97-47	Portavasos	228	532 19 51-61	Sujetador del travesaño
150	532 43 97-74	Cubierta térmica del conducto	234	532 40 47-42	Cubierta Capota
151	532 43 66-70	Soporte	235	532 40 61-29	Separador del guardabarros
152	532 43 98-70	Protector contra oscurecimiento	236	873 93 05-00	Tuerca de presión 5/16-18 unc
159	817 00 06-12	Tornillo 3/8-16 x 3/4	287	817 60 04-06	Tornillo 1/4 - 20 x 3/8
162	532 14 24-32	Tornillo	297	532 43 74-56	Inserto LI
175	532 19 63-04	Travesaño	335	532 44 82-04	Cubierta LD
176	532 40 07-76	Tornillo de 10-24 x 5/8	336	532 44 53-09	Cubierta LI
177	532 19 52-28	Buje de dirección	350	532 44 51-43	Clip del árbol de navidad
180	532 41 50-63	Chasis			
181	532 40 30-25	Buje de soporte del guardabarros de carga			
182	532 40 68-59	Tablero inferior			
183	874 52 05-20	Perno 5/16-18 x 1-1/4			
189	817 00 05-12	Tornillo 5/16-18 x 3/4			
191	532 43 74-55	Inserto LD			

NOTA: Las dimensiones de todos los componentes están expresadas en pulgadas americanas. 1 pulgada = 25,4 mm

TRACTOR - MODELO NO. YTA22V46 (96043021200), PRODUCTO NO. 960 43 02 12
TRANSMISIÓN

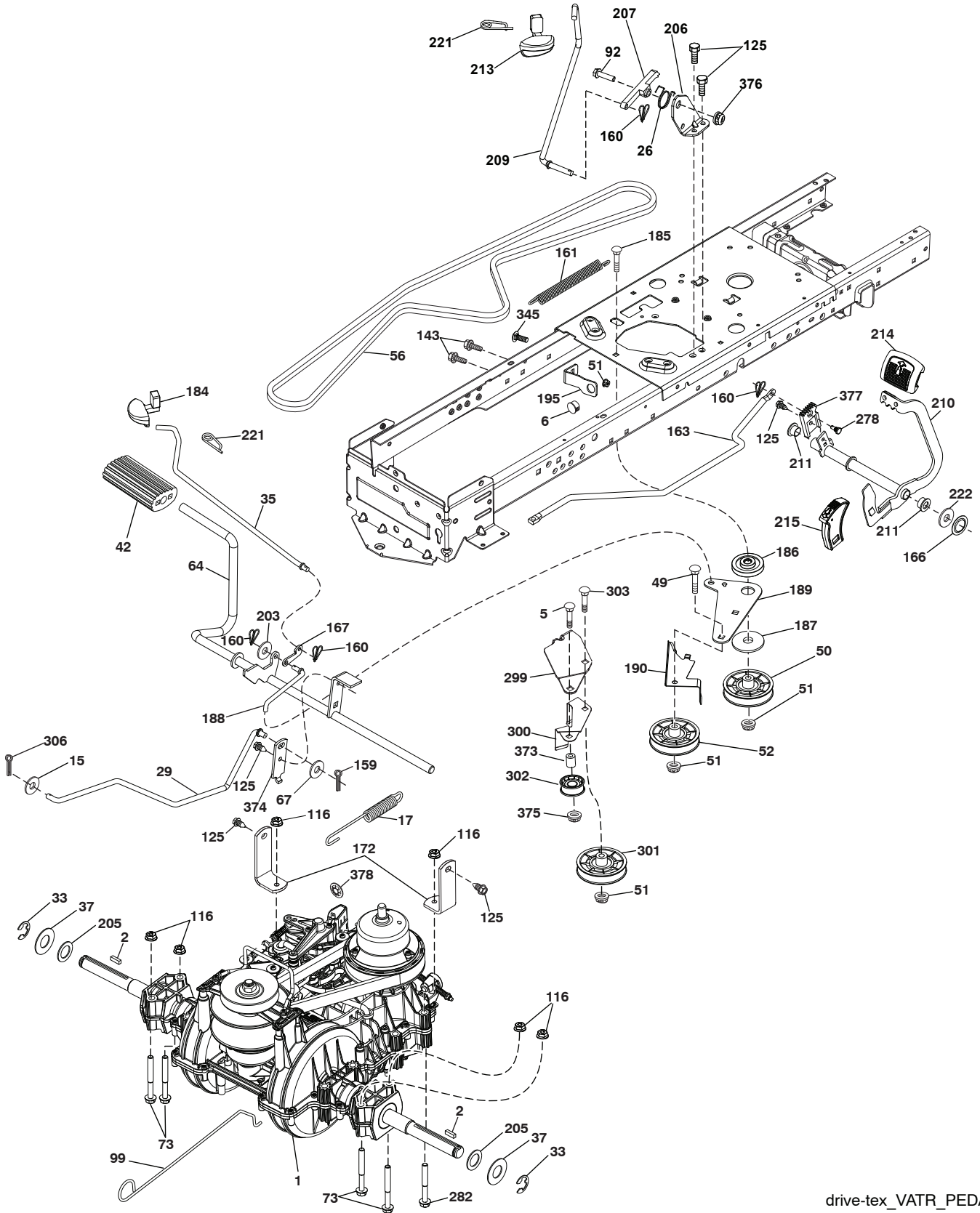

drive-tex_VATR_PEDAL_35

TRACTOR - MODELO NO. YTA22V46 (96043021200), PRODUCTO NO. 960 43 02 12

TRANSMISIÓN

CÓDIGO NO.	PIEZA NO.	DESCRIPCIÓN	CÓDIGO NO.	PIEZA NO.	DESCRIPCIÓN
1	---	Transeje, Varitor SD Pedal (584973901) (Haga el pedido de las piezas al fabricante del transeje.)	189	532 19 43-17	Palanca acodada del mecanismo de desplazamiento
2	532 12 35-83	Cuña	190	532 19 43-18	Sujetador de la palanca acodada del mecanismo de desplazamiento
5	874 76 06-36	Perno de HS 3/8-16 unc	195	581 50 46-01	Soporte del freno
6	532 12 40-28	Buje	203	819 11 11-16	Arandela de 11/32x11/16x calibre 16
15	819 13 13-16	Arandela de 13/32x13/16x calibre 16	205	532 12 17-48	Arandela de 25/32x1-5/8x calibre 16
17	584 95 40-01	Resorte de freno	206	532 44 85-96	Soporte de montaje del bloqueo del crucero
26	532 19 96-79	Crucero con retorno de muelle	207	532 44 82-64	Bloqueo del control del crucero
29	584 82 31-01	Varilla del freno	209	532 19 95-92	Varilla de control del crucero
33	812 00 00-01	Aro E	210	532 44 82-70	Ensamble del pedal
35	583 86 45-01	Varilla del freno de mano	211	532 12 01-83	Rodamiento de nylon
37	532 18 89-67	Arandela de .793 x 1.637 x 060	213	532 40 31-19	Perilla de control del crucero
42	532 12 48-72	Cubierta del pedal	214	532 42 12-63	Forro del pedal para avanzar
49	872 11 06-14	Perno de 3/8-16unc x1-3/4 grado 5	215	532 44 82-54	Forro del pedal para retroceder
50	532 19 43-27	Polea loca plana	221	532 40 31-87	Abrazadera de retención del resorte de la manija
51	873 90 06-00	Tuerca 3/8-16	222	879 21 20-10	Arandela de 21/32 x 1-1/4 calibre 10
52	532 19 43-26	Polea loca con ranura en V con un desplazamiento	278	580 36 91-01	Perno
56	532 19 72-53	Correa de la transmisión	282	874 49 05-48	Tornillo de 5/16-18 x 3
64	532 44 83-53	Ensamble del eje Control del pedal de freno	298	532 41 56-83	Soporte
67	819 13 13-12	Arandela de 13/32 x 13/16 x calibre 12	300	532 41 56-81	Polea loca Sujetador
73	874 49 05-44	Perno de 5/16-18 Gr. 5	301	532 41 56-80	Polea loca plana
92	874 76 05-20	Perno	302	581 42 05-01	Polea loca plana 2.0 Od
99	532 43 59-35	Varilla del con resorte de desviación	303	872 11 06-18	Perno
116	873 90 05-00	Tuerca 5/16-18 unc	306	876 02 04-16	Pasador de chaveta de 1/8 x 1
125	817 00 05-12	Tornillo de 5/16-18 x 3/4	345	872 11 06-06	Perno de 3/8-16 x 1 grado 5
143	817 49 05-08	Tornillo de 5/16-18 x 1/2 Tytt	373	581 46 18-01	Separador
159	876 02 04-12	Pasador de chaveta de 1/8 x 3/4	374	581 47 52-01	Soporte
160	532 16 94-84	Abrazadera de retención	375	873 68 06-00	Tuerca 3/8-16 unc
161	532 10 57-09	Resorte de retorno del embrague 6.75	376	532 42 65-89	Tuerca
163	587 84 79-02	Varilla de control del pedal	377	584 30 34-01	Crucero con Engranaje del sector
166	532 42 91-64	Tuerca de presión .625	378	584 28 77-01	Tuerca 8mm
167	532 40 52-57	Pestillo del freno de mano			
172	583 97 42-01	Correa de torsión (LI)/(LD)			
184	587 65 37-01	Manija del freno de mano			
185	872 11 06-22	Perno de 3/8-16 unc x 2-3/4 grado 5			
186	532 19 43-21	Espaciador de retención			
187	819 13 32-10	Arandela de 13/32 x 2 x calibre 10			
188	532 19 43-23	Mecanismo de desplazamiento de la varilla de mando del embrague			

NOTA: Las dimensiones de todos los componentes están expresadas en pulgadas americanas.
1 pulgada = 25,4 mm

**TRACTOR - MODELO NO. YTA22V46 (96043021200), PRODUCTO NO. 960 43 02 12
MOTOR**

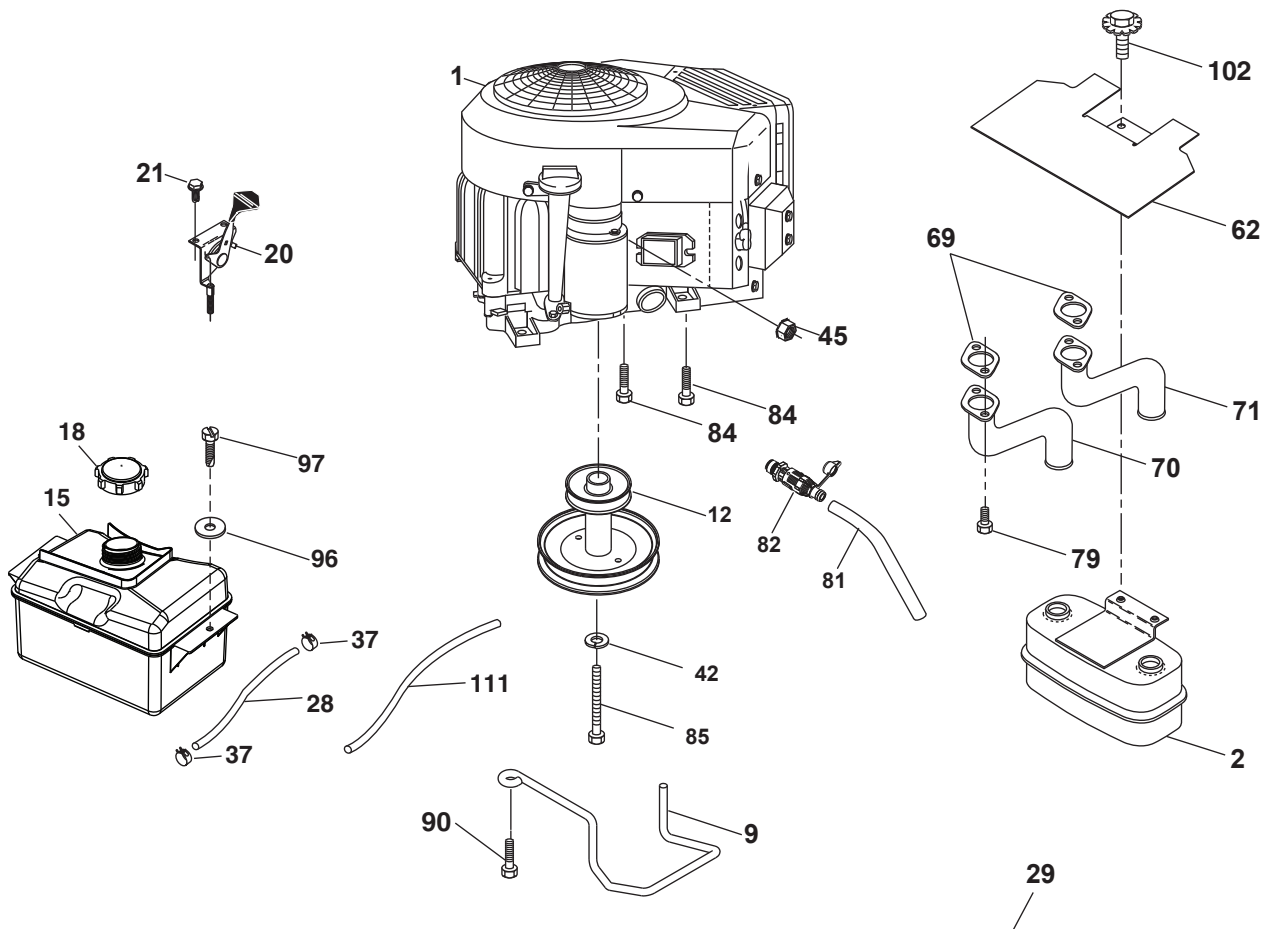

EQUIPO APAGACHISPAS

engine-tex_bs-2cyl_71_r1

TRACTOR - MODELO NO. YTA22V46 (96043021200), PRODUCTO NO. 960 43 02 12 MOTOR

CÓDIGO No.	PIEZA No.	DESCRIPCIÓN
1	-----	Motor B&S modelo No. 44N677-0005-G1 (587639101) (Haga el pedido de las piezas al fabricante del motor.)
2	532 44 59-62	Silenciador
9	584 91 16-01	Ensamble del sujetador de la correa del motor
12	532 40 51-40	Polea del motor
15	532 43 30-07	Tanque de combustible
18	581 17 61-01	Ensamble de la tapa
20	532 42 35-02	Control del regulador
21	532 41 63-58	Tornillo No. 10 x 0,75
28	532 40 11-37	Línea de combustible
29	532 13 71-80	Equipo apagachispas
37	532 12 34-87	Abrazadera de la manguera
42	810 04 07-00	Arandela de presión de 7/16
45	873 51 04-00	Tuerca
62	532 43 40-17	Protector
69	532 16 53-91	Junta
70	581 88 11-01	Tubo de escape LI
71	581 88 10-01	Tubo de escape LD
79	532 18 39-06	Tornillo 5/16-18 x 1
81	532 14 84-56	Tubo de fácil drenaje de aceite
82	532 42 82-87	Conector del drenaje de aceite
84	817 06 06-20	Tornillo 3/8-16 x 1-1/4
85	532 17 39-37	Perno 7/16-20 x 4 x Gr. 5-1.5
90	817 00 06-16	Tornillo 3/8-16 x 1
96	819 09 14-16	Arandela 9/32 x 7/8 x 16
97	817 67 04-12	Tornillo 1/4-20 x 3/4
102	817 00 05-12	Tornillo 5/16-18 x 3/4
111	532 41 41-19	Línea de purge

NOTA: Las dimensiones de todos los componentes están expresadas en pulgadas americanas. 1 pulgada = 25,4 mm

Para las piezas del servicio y de recambio del motor, llame el número gratis para su fabricante del motor enumerado abajo:
Briggs & Stratton 1-800-233-3723

Información de Clasificación de Potencia del Motor

La clasificación de potencia para un modelo de motor a gas en particular se designa de acuerdo al código J1940 de SAE (Sociedad de Ingenieros Automotrices) (Procedimiento de Clasificación de Potencia & Torque del Motor Pequeño), y la clasificación de desempeño ha sido obtenida y corregida de acuerdo con el código J1995 de SAE (Revisión 2002-05). Los valores de torque se obtienen a 3060 RPM; los valores de potencia se obtienen a 3600 RPM. La potencia bruta actual del motor será inferior y está afectada, entre otras cosas, por las condiciones ambientales operativas y la variabilidad de motor a motor. Dado ambos un amplio conjunto de productos en los cuales son puestos nuestros motores, y la variedad de emisiones ambientales aplicables al operar el equipo, el motor a gas no desarrollará la potencia nominal cuando sea usado en una parte del equipo acoplado (potencia real "en el-sitio" o potencia neta). Esta diferencia se debe a una variedad de factores que incluyen, pero que no están limitados a, accesorios (filtro de aire, sistema de escape, sistema de carga, sistema de enfriamiento, carburador, bomba de combustible, etc.) limitaciones de la aplicación, condiciones ambientales de operación (temperatura, humedad, altitud), y la variabilidad de motor a motor. Debido a las limitaciones, Briggs & Stratton puede sustituir este motor con clasificación de potencia más alta por esta serie de motor.

TRACTOR - MODELO NO. YTA22V46 (96043021200), PRODUCTO NO. 960 43 02 12
ENSAMBLE DE LA DIRECCIÓN

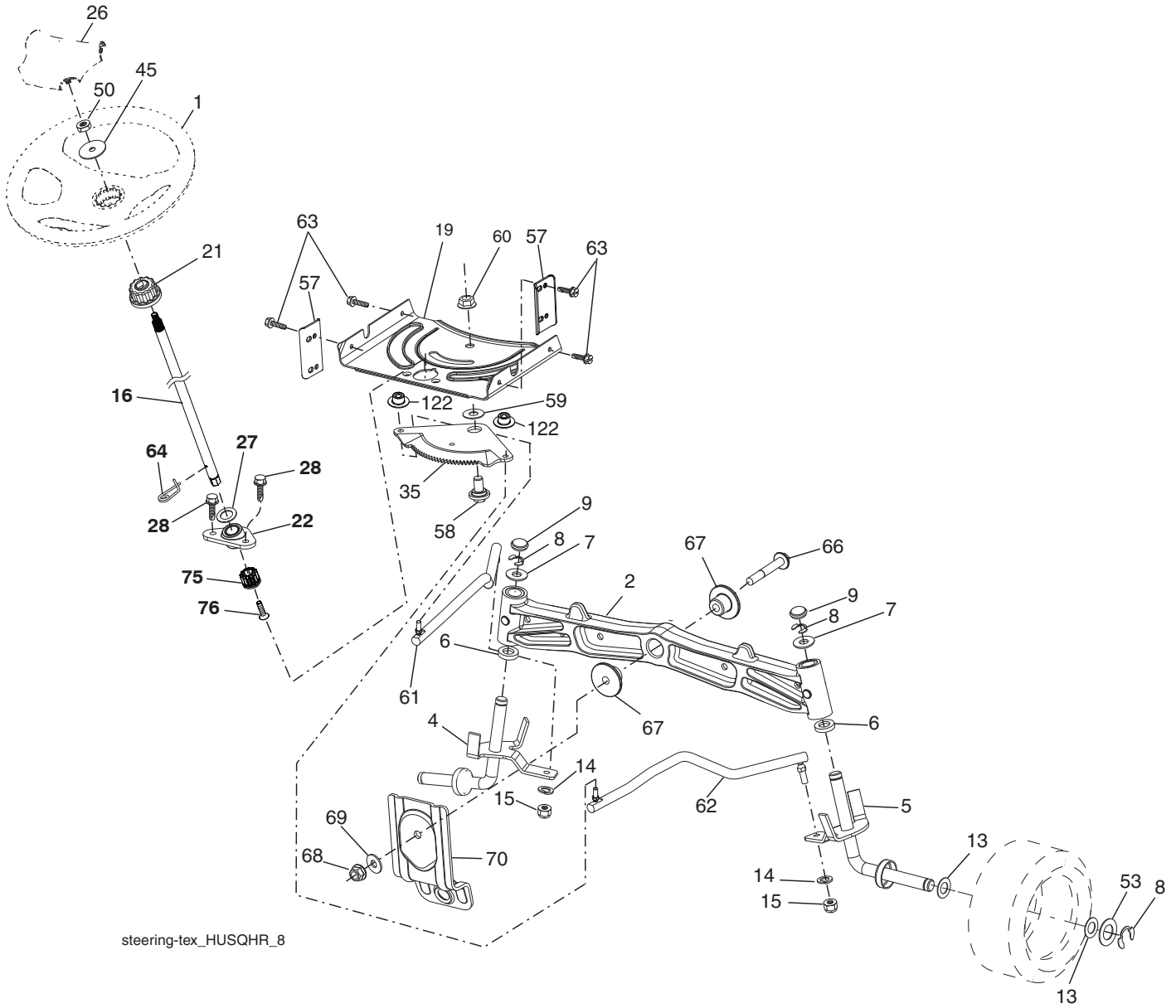

steering-tex_HUSQHR_8

**TRACTOR - MODELO NO. YTA22V46 (96043021200), PRODUCTO NO. 960 43 02 12
ENSAMBLE DE LA DIRECCIÓN**

CÓDIGO PIEZA		DESCRIPCIÓN
No.	No.	
1	532 43 97-40	Volante de dirección
2	532 19 59-68	Eje
4	532 40 30-87	Ensamble del husillo izquierdo
5	532 40 30-88	Ensamble del husillo derecho
6	532 12 49-31	Arandela
7	532 12 17-48	Arandela de 25/32 x 1-5/8 calibre 16
8	812 00 00-29	Abrazadera del aro No. T5304-75
9	532 12 12-32	Tapa del husillo
13	532 12 17-49	Arandela de 25/32 x 1-1/4 calibre 16
14	810 04 06-00	Arandela de presión de 3/8
15	873 54 06-00	Tuerca corona de presión de 3/8-24 unf
16	587 01 60-02	Eje de dirección
19	532 19 47-29	Placa de dirección
21	586 84 02-01	Adaptador del volante de dirección
22	585 02 98-02	Rodamiento
26	532 43 97-43	Inserto del volante de dirección
27	819 21 16-16	Arandela
28	817 00 06-12	Tornillo de 3/8-16 x 3/4
35	532 19 47-32	Engranaje del sector de la placa
45	587 01 64-01	Arandela 3/8 ID 2-3/8 OD calibre 12 PLTD
50	873 90 06-00	Tuerca 3/8-16 unc
53	532 18 89-67	Arandela reforzada de 793 x 1637 x 0,060
57	532 40 74-65	Tope superior del soporte
58	532 19 47-47	Perno de tope del sector del pivote CFM
59	532 19 47-48	Arandela de empuje del sector de dirección
60	873 97 10-00	Tuerca de presión con brida de 5/8-11
61	532 19 47-40	Barra de acoplamiento izquierda
62	532 19 47-41	Barra de acoplamiento derecha
63	817 00 05-12	Tornillo de 5/16-18 x 3/4
64	532 19 98-49	Abrazadera de retención del resorte de la dirección
66	871 02 07-48	Perno de cabeza 7/16-14 x 3
67	532 19 47-37	Buje PM del eje delantero
68	873 90 07-00	Tuerca de presión con brida de 7/16-14 grado 5
69	532 19 91-62	Arandela de 1,5 x 0,505 x 0,118
70	585 33 88-01	Soporte de la plataforma delantera
75	580 68 37-01	Piñón
76	580 68 36-01	Tornillo
122	532 44 49-62	Tapas

NOTA: Las dimensiones de todos los componentes están expresadas en pulgadas americanas. 1 pulgada = 25,4 mm

TRACTOR - MODELO NO. YTA22V46 (96043021200), PRODUCTO NO. 960 43 02 12
PLATAFORMA DE LA CORTADORA DE CÉSPED

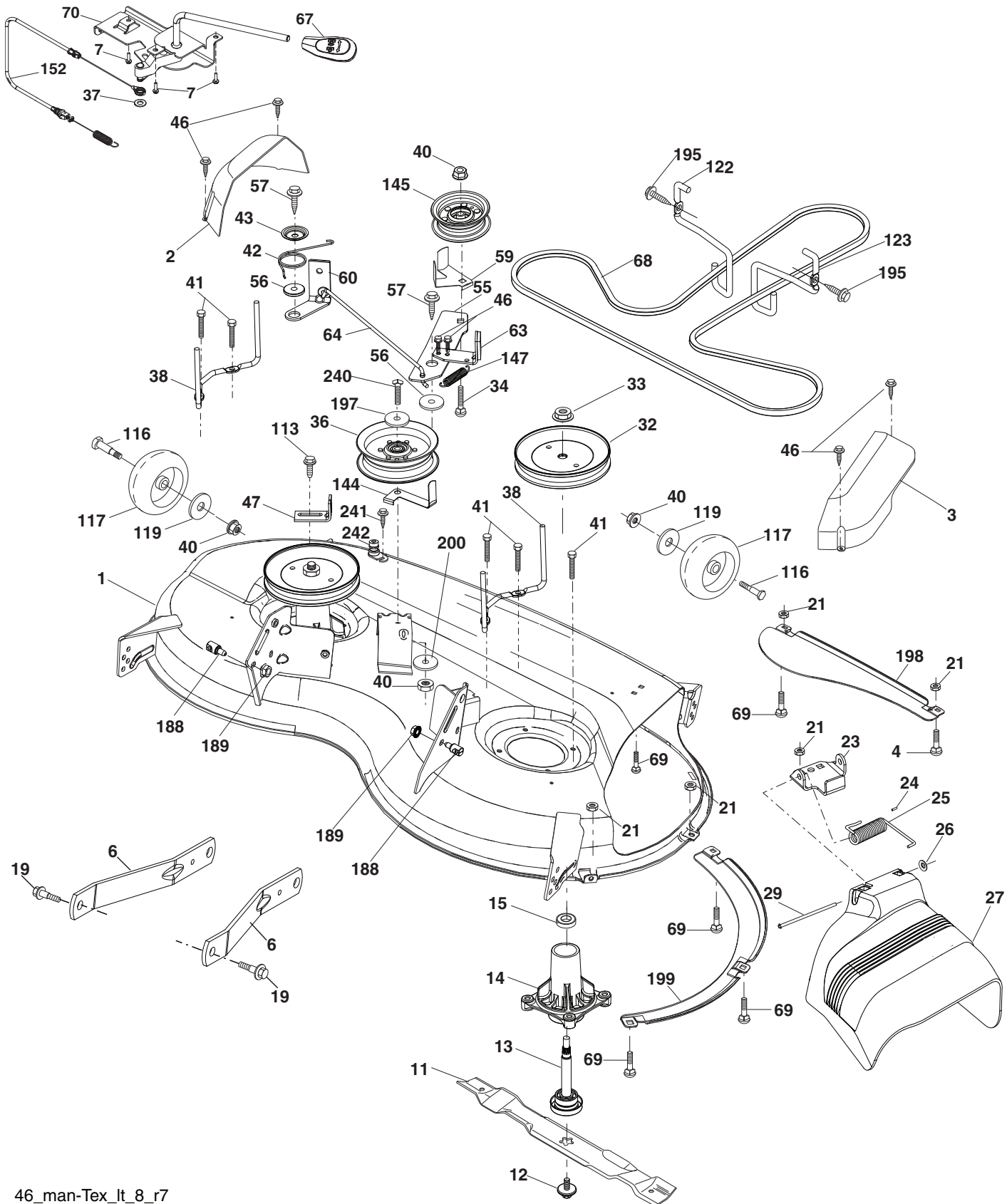

46_man-TeX_lt_8_r7

**TRACTOR - MODELO NO. YTA22V46 (96043021200), PRODUCTO NO. 960 43 02 12
PLATAFORMA DE LA CORTADORA DE CÉSPED**

CÓDIGO No.	PIEZA No.	DESCRIPCIÓN	CÓDIGO No.	PIEZA No.	DESCRIPCIÓN
1	586 29 31-01	Carcasa de la cortadora de césped	64	532 40 51-38	Varillaje del freno
2	532 40 55-06	Cubierta derecha del mandril	67	532 40 30-12	Manija del cable de embrague
3	532 40 55-07	Cubierta izquierda del mandril	68	532 40 51-43	Correa trapezoidal
4	874 76 05-12	Perno de cabeza hexagonal de 5/16-18	69	872 14 05-05	Perno
6	532 19 51-86	Brazo de la suspensión	70	532 19 99-72	Ensamble del embrague Manual
7	532 41 63-58	Tornillo No. 10 x 0,750	113	817 00 05-10	Tornillo de 5/16-18
11	532 40 53-80	Cuchilla de la cortadora	116	532 19 34-06	Perno de tope
12	584 30 93-01	Tornillo 7/16-20 x 1	117	532 17 48-73	Calibrador de la rueda
13	532 19 28-72	Ensamble del eje del mandril	119	819 13 20-12	Arandela de 13/32x1-1/4xcalibre 12
14	532 18 72-81	Carcasa del mandril	122	532 19 72-58	Sujetador izquierdo de la correa del motor
15	532 11 04-85	Rodamiento de bolas del mandril	123	532 19 72-59	Sujetador derecho de la correa del motor
19	532 19 65-39	Perno de tope	144	532 19 92-04	Sujetador de la correa
21	873 68 05-00	Tuerca	145	532 19 31-97	Polea loca
23	532 19 25-57	Soporte del deflector	147	532 40 18-72	Retorno del resorte
24	532 10 53-04	Tapa de la manga	152	584 24 35-01	Cable de embrague manual con resorte
25	532 19 70-26	Resorte de torsión del deflector	188	532 19 51-61	Sujetador del travesaño
26	532 11 04-52	Tuerca de presión	189	873 90 05-00	Tuerca de presión hexagonal con brida
27	532 40 53-57	Protector del deflector	195	817 00 06-12	Tornillo de 3/8-16 x 3/4
29	532 13 14-91	Varilla de la bisagra	197	819 13 13-12	Arandela de 13/32x13/16xcalibre 12
32	532 19 74-73	Polea del mandril	198	532 40 31-49	Deflector delantero central
33	532 40 02-34	Tuerca de seguridad con brida	199	532 40 31-50	Deflector delantero derecho
34	872 11 06-12	Perno de 3/8-16 x 1-1/2 grado 5	200	532 41 35-24	Arandela de 13/32 x 1 x 1/2 calibre 11
36	532 19 73-79	Polea loca	240	874 52 06-36	Perno 3/8-16 unc x 2-1/4
37	819 13 13-16	Arandela de 13/32x13/16xcalibre 16	241	532 15 29-27	Tornillo
38	532 43 25-20	Sujetador de la correa izquierda del mandril	242	532 41 55-98	Puerto de Lavado de la Cubierta
40	873 90 06-00	Tuerca de presión con brida de 3/8-16 unc	--	532 41 64-05	Accesorio del conexion
41	584 95 39-01	Arandela 313-18 x 1.19	--	587 25 33-01	Ensamble del Mandril (solo incluye la carcasa (#14), el ensamble del eje (#13) y el rodamiento (#15); no incluye la polea/tuerca/arandela ni los pernos/arandelas de la cuchilla)
42	532 19 84-10	Resorte de torsión del freno			Reemplazo de la cortadora de césped, completa
43	532 19 72-56	Resorte de torsión de retención			
46	532 13 77-29	Tornillo			
47	532 19 72-50	Soporte del cable de embrague			
55	532 19 72-49	Brazo de la polea			
56	532 19 90-92	Espaciador de retención	--	532 43 18-23	
57	817 00 06-16	Tornillo hexagonal con arandela de 3/8-16 x 1			
59	532 14 10-43	Dispositivo de protección de la polea (94)			
60	532 19 94-71	Brazo izquierdo del freno de la cortadora de césped			
63	532 19 94-77	Brazo del freno de la cortadora de césped			

NOTA: Las dimensiones de todos los componentes están expresadas en pulgadas americanas. 1 pulgada = 25,4 mm

TRACTOR - MODELO NO. YTA22V46 (96043021200), PRODUCTO NO. 960 43 02 12
ELEVACIÓN DE LA CORTADORA DE CÉSPED

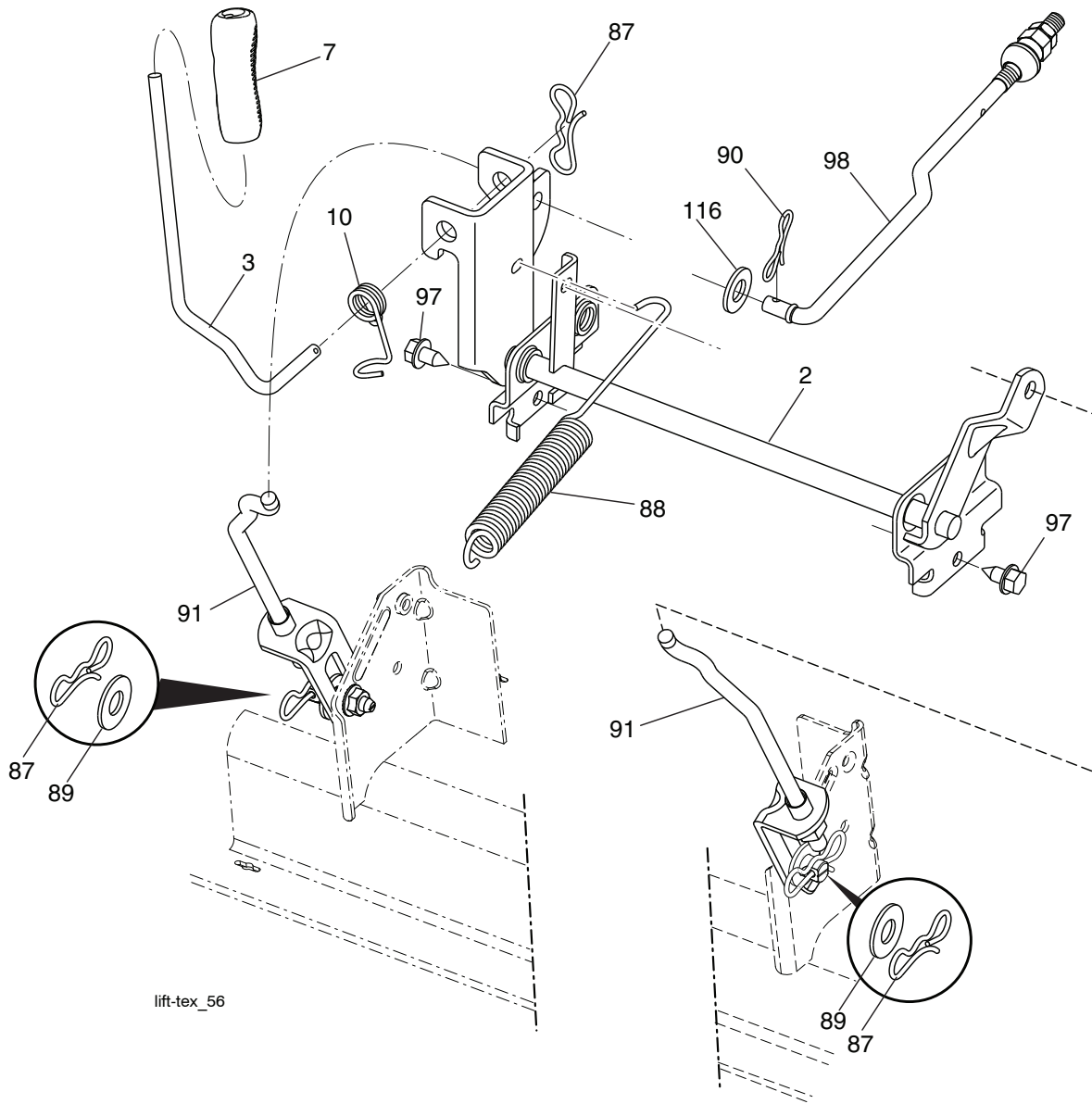

CÓDIGO PIEZA
No. No.

DESCRIPCIÓN

2	532 42 20-27	Ensamble del eje de la elevación
3	532 19 52-31	Ensamble de la palanca de elevación derecha
7	580 96 23-01	Mango de la palanca
10	532 19 63-14	Resorte de torsión
87	532 19 42-09	Pasador de chaveta de 7/16 con bloqueo en forma de mariposa
88	532 41 07-10	Resorte de ayuda de la elevación
89	819 19 19-12	Arandela de zinc transparente
90	532 19 42-08	Pasador de chaveta de 5/16 con bloqueo en forma de mariposa

CÓDIGO PIEZA
No. No.

DESCRIPCIÓN

91	532 19 79-84	Ensamble del acoplamiento
97	817 00 06-12	Tornillo de 3/8-16 x 0,75
98	532 42 05-25	Acoplamiento frontal de la elevación de la cortadora de césped
116	819 15 15-16	Arandela 15/32 x 15/16 x calibre 16

NOTA: Las dimensiones de todos los componentes están expresadas en pulgadas americanas. 1 pulgada = 25,4 mm

**TRACTOR - MODELO NO. YTA22V46 (96043021200), PRODUCTO NO. 960 43 02 12
ENSAMBLE DEL ASIENTO**

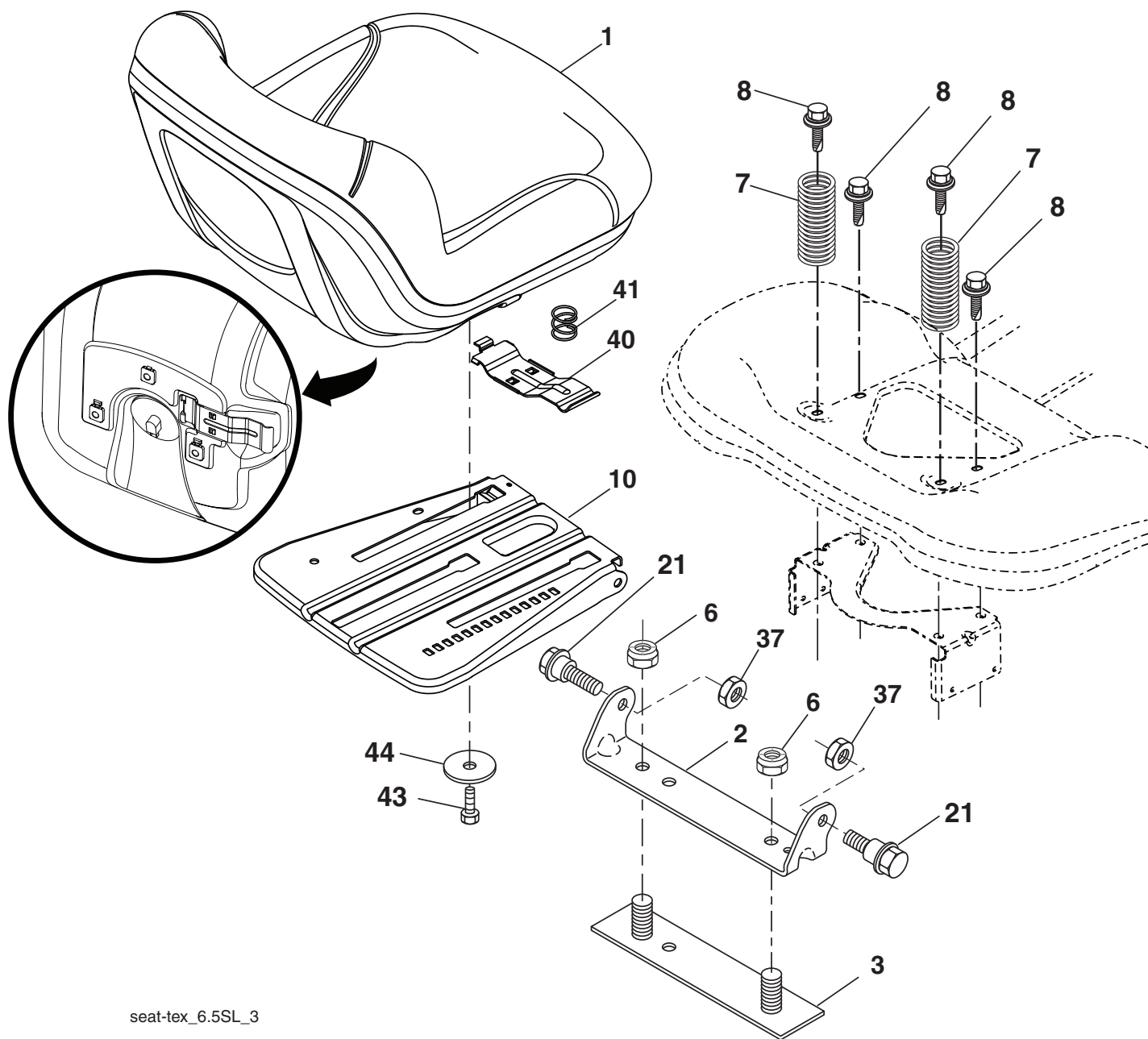

seat-tex_6.5SL_3

CÓDIGO No.	PIEZA No.	DESCRIPCIÓN
1	532 43 98-22	Asiento
2	532 18 01-66	Soporte pivotante del guardabarros
3	532 14 06-75	Conector del ensamble del guardabarros
6	873 80 06-00	Tuerca de presión c/aislamiento de 3/8-16 unc
7	587 61 33-01	Resorte del asiento
8	532 17 18-77	Perno de 5/16" unc x 3/4"
10	532 19 69-77	Bandeja del asiento
21	587 90 78-01	Perno de tope de 5/16-18 x 5/8

CÓDIGO No.	PIEZA No.	DESCRIPCIÓN
37	873 80 05-00	Tuerca de presión de 5/16-18 unc
40	532 43 98-71	Manija para deslizar el asiento
41	532 19 82-00	Resorte para trabar el asiento
43	874 76 06-12	Perno de cabeza hexagonal con aleta de 3/8-16 unc x 3/4
44	819 13 38-12	Arandela de 13/32 x 2-3/8 calibre 12

NOTA: Las dimensiones de todos los componentes están expresadas en pulgadas americanas. 1 pulgada = 25,4 mm

**TRACTOR - MODELO NO. YTA22V46 (96043021200), PRODUCTO NO. 960 43 02 12
CALCOMANÍAS**

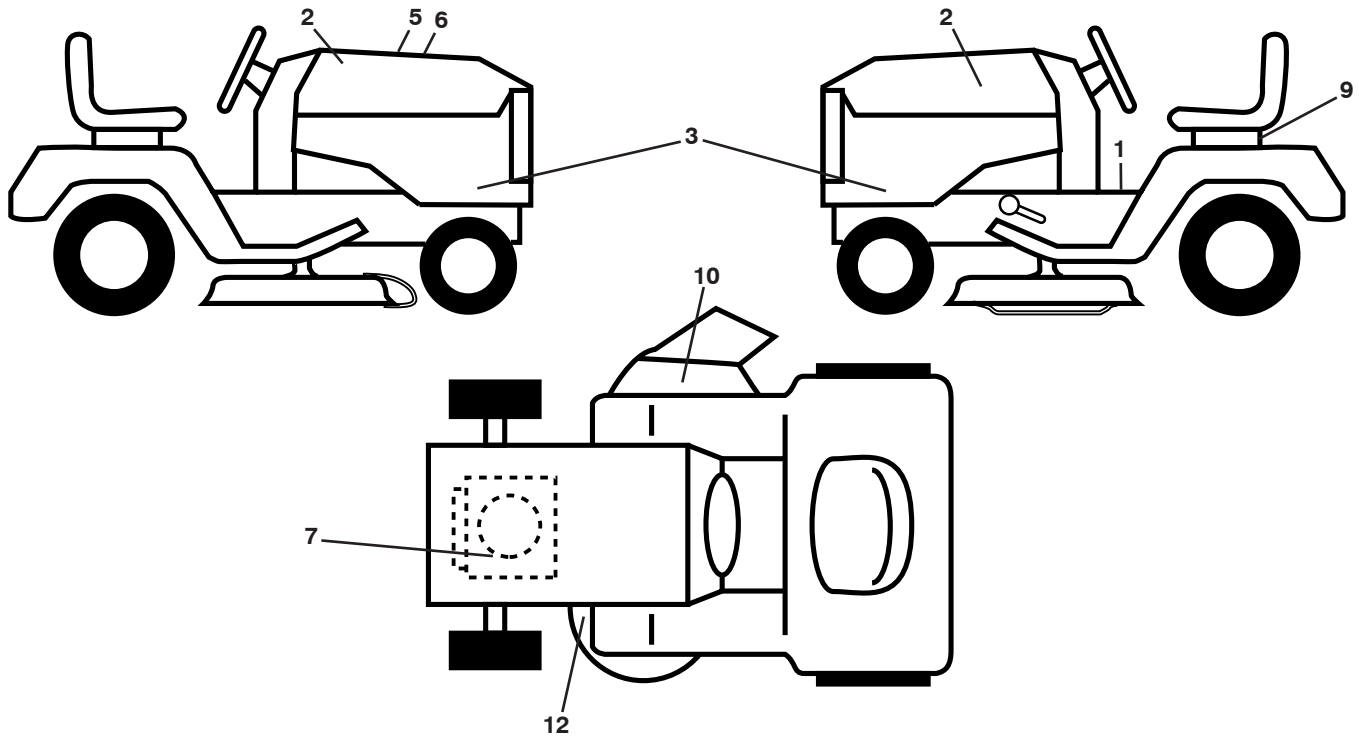

**CÓDIGO PIEZA
No. No.**

CÓDIGO PIEZA No.	No.	DESCRIPCIÓN
1	581 57 89-01	Calcomanía para el guardabarros
2	581 62 73-01	Calcomanía para la capota
3	501 20 38-01	Calcomanía para el panel capota
5	532 42 38-29	Calcomanía del operador
6	501 11 22-01	Calcomanía de reemplazo
7	585 55 69-01	Calcomanía de motor B&S
9	532 14 50-05	Calcomanía de Peligro/Punto de interconexión
10	584 90 46-01	Calcomanía advertencia
12	581 58 00-01	Calcomanía del diagrama de la cortadora de césped

**CÓDIGO PIEZA
No. No.**

CÓDIGO PIEZA No.	No.	DESCRIPCIÓN
--	581 72 48-01	Calcomanía para la desviación
--	532 43 96-81	Forro del apoyo para los pies (LI)
--	532 43 96-82	Forro del apoyo para los pies (LD)
--	115 77 70-26	Manual de Operario (Inglês/Español)
--	501 40 84-01	Manual de Repuestos (Inglês/Español)
--	587 71 00-26	Guía de inicio rápido (Inglês/Español)

RUEDAS Y NEUMÁTICOS

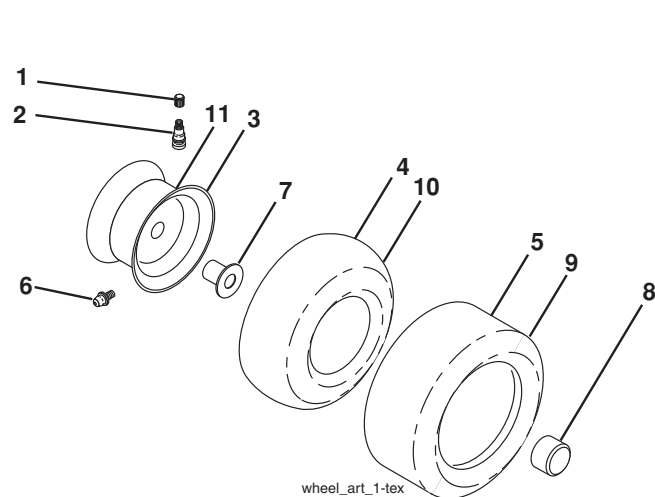

**CÓDIGO PIEZA
No. No.**

CÓDIGO PIEZA No.	No.	DESCRIPCIÓN
1	532 05 91-92	Tapa de la válvula del neumático
2	532 06 51-39	Vástago de la válvula
3	532 13 83-36	Ensamble de las llantas delanteras
4	532 05 99-04	Cámara delantera (Mantenimiento sólo)
5	532 10 62-22	Neumático delantero de 15 x 6-6
6	532 12 49-57	Accesorio para engrasar (solo para la rueda delantera)
7	532 12 49-59	Rodamiento de la brida (solo para la rueda delantera)
8	532 17 50-39	Tapa del eje 1 50 x 1 00
9	532 13 84-68	Neumático trasero de 20 x 8-8
10	532 12 49-26	Cámara trasera (Mantenimiento sólo)
11	532 13 83-37	Ensamble trasero de la llanta 8"
--	532 14 43-34	Sellador para neumáticos (tubo de 10 onzas [283 gr])

NOTA: Las dimensiones de todos los componentes están expresadas en pulgadas americanas. 1 pulgada = 25,4 mm

SERVICE NOTES/AVISO

08/10/2015 BD