

YTH24V54

ILLUSTRATED PARTS LIST

TRACTOR - MODEL NO. YTH24V54 (96043009301), PRODUCT NO. 960 43 00-93 SCHEMATIC

SCH12

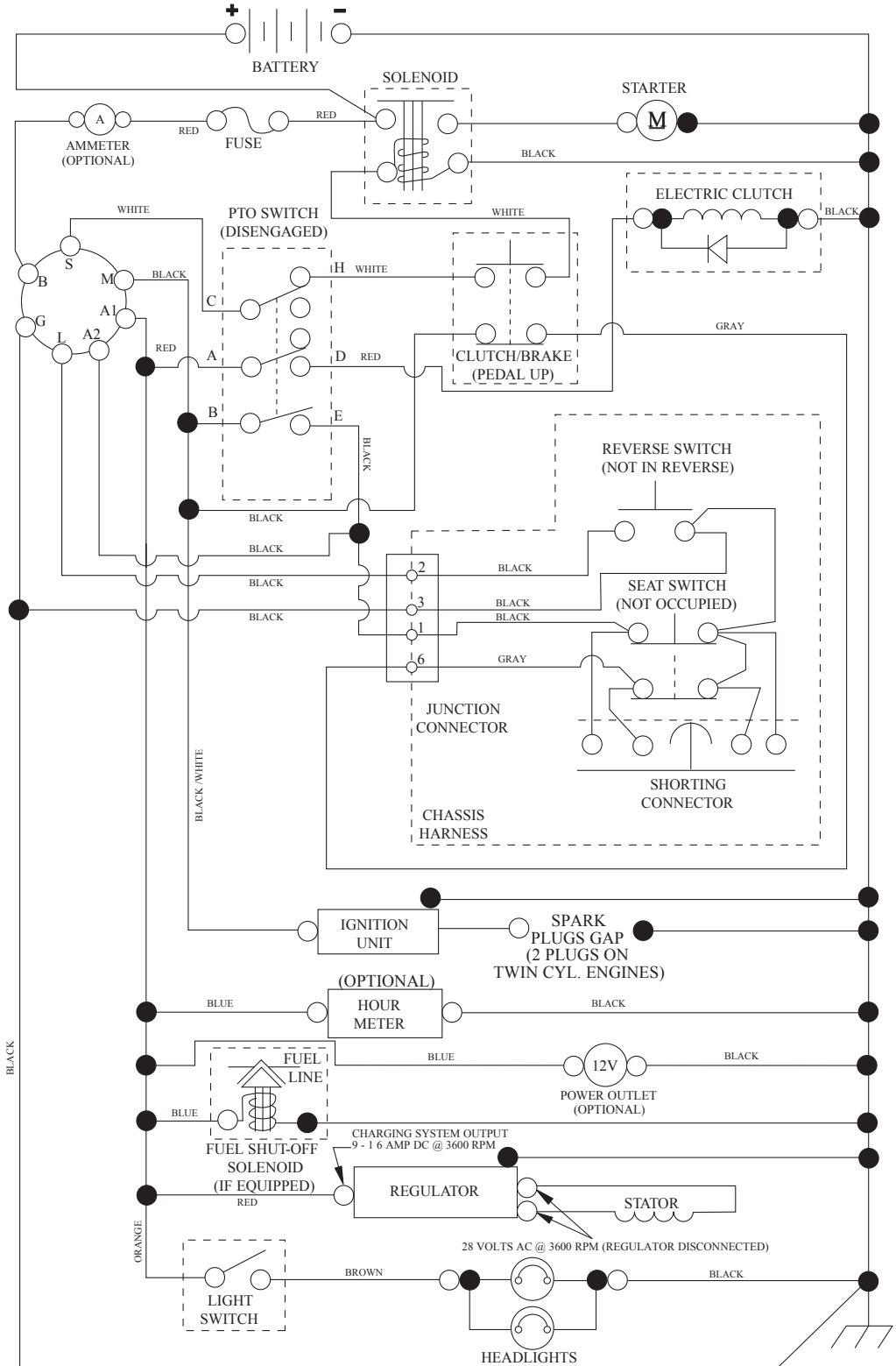

PTO SWITCH (MATING SIDE)

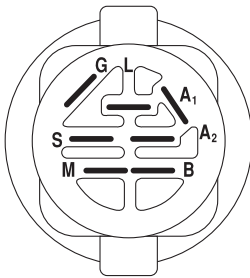

POSITION	CIRCUIT	"MAKE"
OFF	M+G+A1	
RUN/OVERRIDE	B+A1	
RUN	B+A1	L+A2
START	B + S + A1	

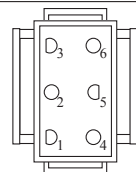

CHASSIS HARNESS CONNECTOR (MATING SIDE)

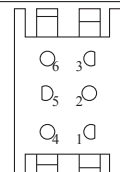

DASH HARNESS CONNECTOR

WIRING INSULATED CLIPS
NOTE: IF WIRING INSULATED CLIPS WERE REMOVED FOR SERVICING OF UNIT, THEY SHOULD BE RE-INSTALLED TO PROPERLY SECURE YOUR WIRING.

NON-REMOVABLE CONNECTIONS

REMOVABLE CONNECTIONS

**TRACTOR - MODEL NO. YTH24V54 (96043009301), PRODUCT NO. 960 43 00-93
ELECTRICAL**

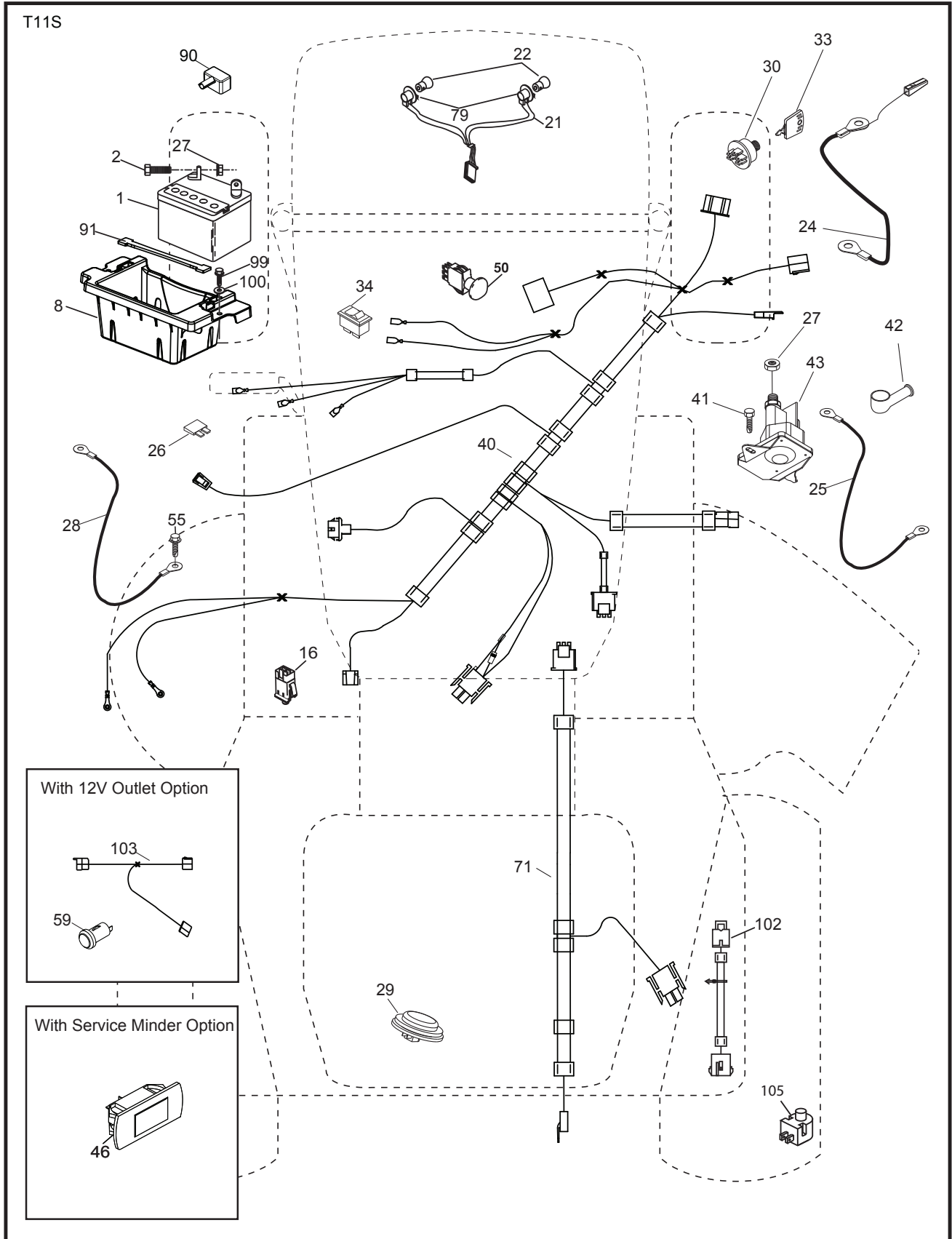

**TRACTOR - MODEL NO. YTH24V54 (96043009301), PRODUCT NO. 960 43 00-93
ELECTRICAL**

KEY NO.	PART NO.	DESCRIPTION
1	532 16 34-65	Battery
2	874 76 04-12	Bolt Hex Hd 1/4-20 unc x 3/4
8	532 18 64-91	Battery Box
16	532 17 61-38	Switch Interlock
21	532 18 37-59	Harness Socket Light
22	532 00 41-52	Bulb, Light # 1156
24	532 40 02-53	Cable Battery
25	532 41 28-95	Cable Starter
26	532 17 51-58	Fuse
27	873 51 04-00	Nut Keps Hex 1/4-20 unc
28	532 14 54-91	Cable Ground 21" Blk 6 Ga.
29	532 40 15-45	Switch Seat
30	532 19 33-50	Switch Ign
33	532 41 19-35	Key / Chain
34	532 11 07-12	Switch Light/Reset
40	532 40 11-04	Harness Ign. Dash
41	817 72 04-08	Screw Thd Cut 1/4-20 x 1/2
42	532 13 15-63	Cover Terminal Red
43	532 19 25-07	Solenoid
46	532 40 17-63	Gauge Hourmeter
50	532 17 46-51	Switch PTO
55	817 06 05-12	Screw Thdrol 5/16-18 x 3/4
71	532 19 42-76	Harness Ign
79	532 17 52-42	Socket Asm Bulb Twistlock
90	532 40 07-24	Cover Terminal Battery
91	532 19 02-70	Strap Battery
99	817 67 04-12	Screw Hexwsh Thdrol 1/4-20 x 3/4
100	819 09 14-16	Washer 9/32 x 7/8 x 16 Ga.
102	532 40 44-54	Harness Pigtail K46 Tex ROS
105	532 40 75-68	Switch Reverse TT Pedal

NOTE: All component dimensions given in U.S. inches
1 inch = 25.4 mm

**TRACTOR - MODEL NO. YTH24V54 (96043009301), PRODUCT NO. 960 43 00-93
CHASSIS**

KEY NO.	PART NO.	DESCRIPTION	KEY NO.	PART NO.	DESCRIPTION
3	532 40 50-12	Logo	196	532 41 45-80	Console Asm. Deck Lift
5	532 40 87-00	Dash Asm	199	532 41 34-85	Plate Deck Lift
14	532 41 10-46	Hood	202	532 40 30-48	Vent Side Hood RH
15	532 19 89-07	Lens LH	203	532 40 30-76	Vent Side Hood LH
18	532 40 86-07	Grille	204	532 41 66-13	Vent Asm Hood Top
25	532 19 89-06	Lens RH	205	532 40 17-09	Skirt Hood Side RH
34	532 19 61-25	Plate Engine	206	532 40 17-11	Skirt Hood Side LH
36	817 06 05-12	Screw 5/16-18 x 3/4	207	532 19 71-98	Bezel RH
37	532 41 86-73	Fender	208	532 19 71-99	Bezel LH
52	873 68 05-00	Nut Lock 5/16-18	209	532 19 91-30	Insert Hex Top RH
58	532 41 22-80	Drawbar, Upper	210	532 19 91-31	Insert Hex Top LH
68	817 49 05-08	Screw 5/16-18 x 1/2	211	532 19 91-32	Insert Hex Bottom RH
130	532 41 63-58	Screw #10 x 0.750	212	532 19 91-33	Insert Hex Bottom LH
137	532 40 75-90	Bumper Dash	213	874 76 05-12	Bolt Hex Hd 5/16-18 unc x 3/4
138	532 40 29-54	Cupholder	214	532 19 91-45	Clip Retainer
150	532 19 85-12	Duct Heat Hood	217	532 40 91-67	Rod Pivot
152	532 19 95-35	Shield Browning/Debris	218	532 19 63-95	Hood Stop
161	532 40 96-27	Console Fuel Window	228	532 19 51-61	Stud Fastner
162	532 14 24-32	Screw Hex Wsh Hi-Lo 1/4 x 1/2	233	532 19 65-39	Bolt Shoulder
165	532 19 68-26	Bracket Support Tank	234	532 40 47-42	Bumper Hood
175	532 19 63-04	Crossmember	235	532 40 61-29	Spacer Fender
176	532 40 07-76	Screw 10-24 x 5/8 Rnd Qdrx	236	873 93 05-00	Nut Lock 5/16-18 unc
177	532 19 52-27	Bushing Steering	238	532 40 86-06	Trim
180	532 41 50-63	Chassis	239	532 11 04-52	Nut Push
181	532 40 30-25	Bushing Mtg. Fender Crgo.	287	817 60 04-06	Screw Hex Washead 1/4-20 x 3/8
182	532 40 68-59	Dash Lower			
183	874 52 05-20	Bolt 5/16-18 x 1-1/4 Full Thd.			
189	817 00 05-12	Screw 5/16-18 x 3/4			
194	873 90 05-00	Nut Lock Hex Flange 5/16-18			
195	532 40 41-37	Plug Hold Dash Lower			

NOTE: All component dimensions given in U.S. inches
1 inch = 25.4 mm

**TRACTOR - MODEL NO. YTH24V54 (96043009301), PRODUCT NO. 960 43 00-93
DRIVE**

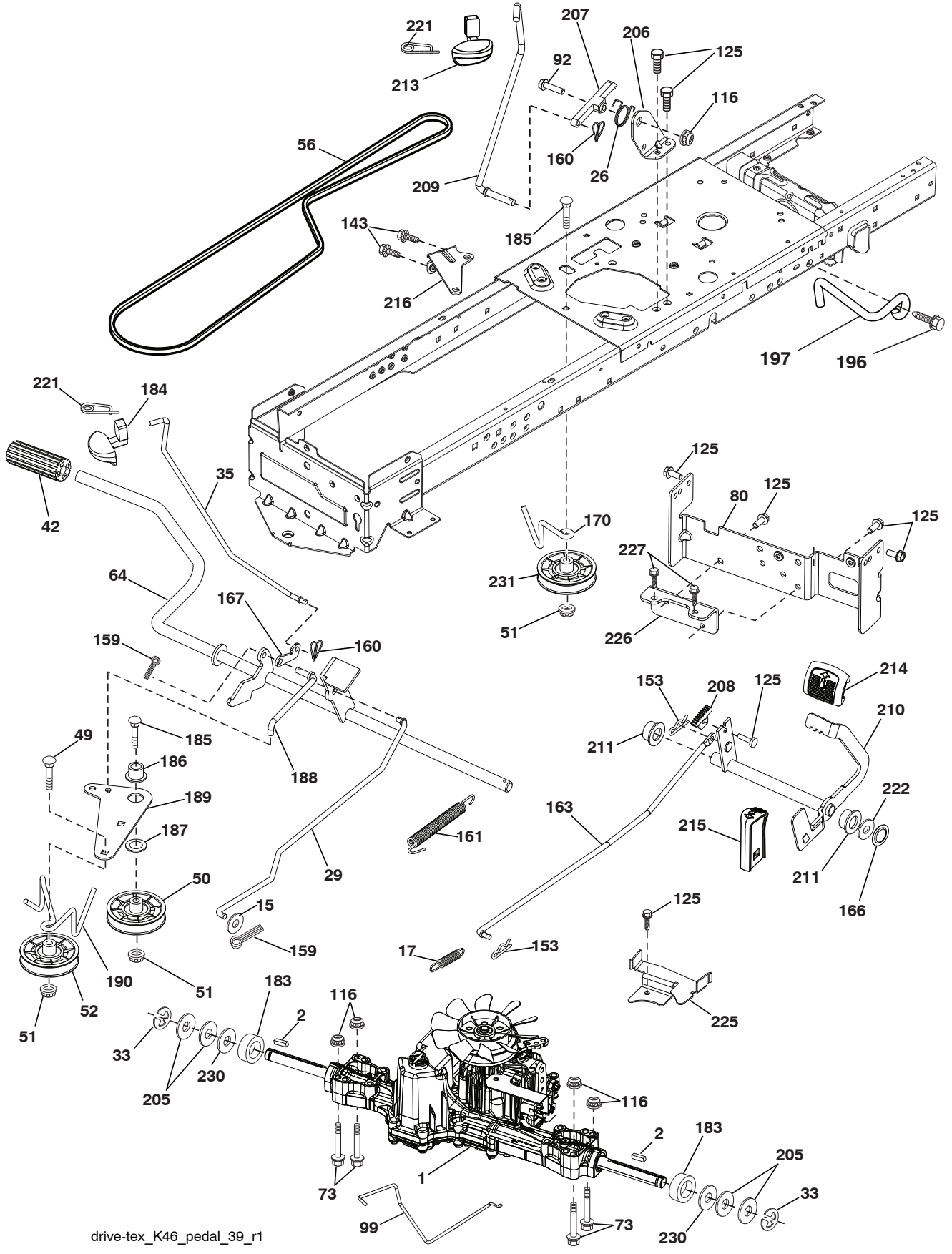

drive-tex_K46_pedal_39_r1

**TRACTOR - MODEL NO. YTH24V54 (96043009301), PRODUCT NO. 960 43 00-93
DRIVE**

KEY NO.	PART NO.	DESCRIPTION	KEY NO.	PART NO.	DESCRIPTION
1	--	Transaxle, TUFFTORQ K46BT	185	872 11 06-22	Bolt 3/8 - 16 x 2-3/4 Gr. 5
2	532 12 35-83	Key	186	532 19 43-21	Spacer Retainer
15	819 13 13-16	Washer 13/32 x 13/16 x 16 Ga.	187	819 13 32-10	Washer
17	532 41 36-78	Spring, Brake	188	532 19 43-23	Link Clutch Ground Drive
26	532 19 96-79	Spring Return Cruise	189	532 19 43-17	Bellcrank Ground Drive
29	532 40 38-06	Rod, Brake	190	532 19 43-18	Keeper Bellcrank Ground Drive
33	812 00 00-01	Ring E	196	817 00 06-16	Screw 3/8-16 x 1
35	532 19 95-91	Rod, Brake, Park	197	532 19 58-04	Bracket Clutch Anti-Rotation
42	532 12 48-72	Cover, Foot Pedal	205	532 12 17-48	Washer
49	872 11 06-14	Bolt	206	532 19 78-67	Bracket Mount Latch Cruise
50	532 19 43-27	Pulley Idler Flat	207	532 19 78-68	Latch Control Cruise
51	873 90 06-00	Lock Nut 3/8-16	208	532 19 78-69	Gear Sector Control Cruise
52	532 19 43-26	Idler V-Groove 910" Offset	209	532 19 95-92	Rod Control Cruise
56	532 13 09-69	V-Belt, Drive	210	532 40 09-80	Rocker Asm. Pedal Control
64	532 19 78-65	Shaft Asm. Pedal Brake Control	211	532 12 01-83	Bearing Nylon
73	874 49 05-44	Bolt 5/16-18 Gr. 5	213	532 40 31-19	Knob Control Cruise
80	532 41 00-24	Strap Torque	214	532 42 12-63	Pedal Forward
92	874 76 05-20	Bolt Fin Hex 5/16-18 unc x 1.25	215	532 40 17-23	Pedal Reverse
99	532 41 57-42	Spring Rod Bypass	216	532 19 61-31	Bracket Pulley Idler
116	873 90 05-00	Nut Lock Hex Flange 5/16-18	221	532 40 31-87	Retainer Spring Clip Handle
125	817 00 05-12	Screw 5/16-18 x 3/4	222	879 21 20-10	Washer 21/32 x 1-1/4 x 10 Ga.
143	817 49 05-08	Screw Thdrol 5/16-18 x 1/2	225	532 40 33-19	Keeper Belt Trans.
153	532 12 47-88	Retainer Spring	226	532 40 15-64	Bracket Mount Touque
159	876 02 04-12	Pin Cotter 1/8 x 3/4	227	817 49 05-12	Screw Thdrol 5/16-18 x 3/4
160	532 16 94-84	Retainer Clip	230	532 18 89-67	Washer
161	532 10 57-09	Spring, Return, Clutch	231	532 40 72-87	Idler V-Groove Pulley
163	532 40 10-34	Rod Pedal Control			
166	532 42 91-64	Nut Push .625			
167	532 40 52-57	Latch Brake Parking			
170	532 41 34-30	Keeper Belt Centerspan			
183	532 13 70-57	Spacer Split			
184	532 40 31-18	Handle Parking Brake			

NOTE: All component dimensions given in U.S. inches
1 inch = 25.4 mm

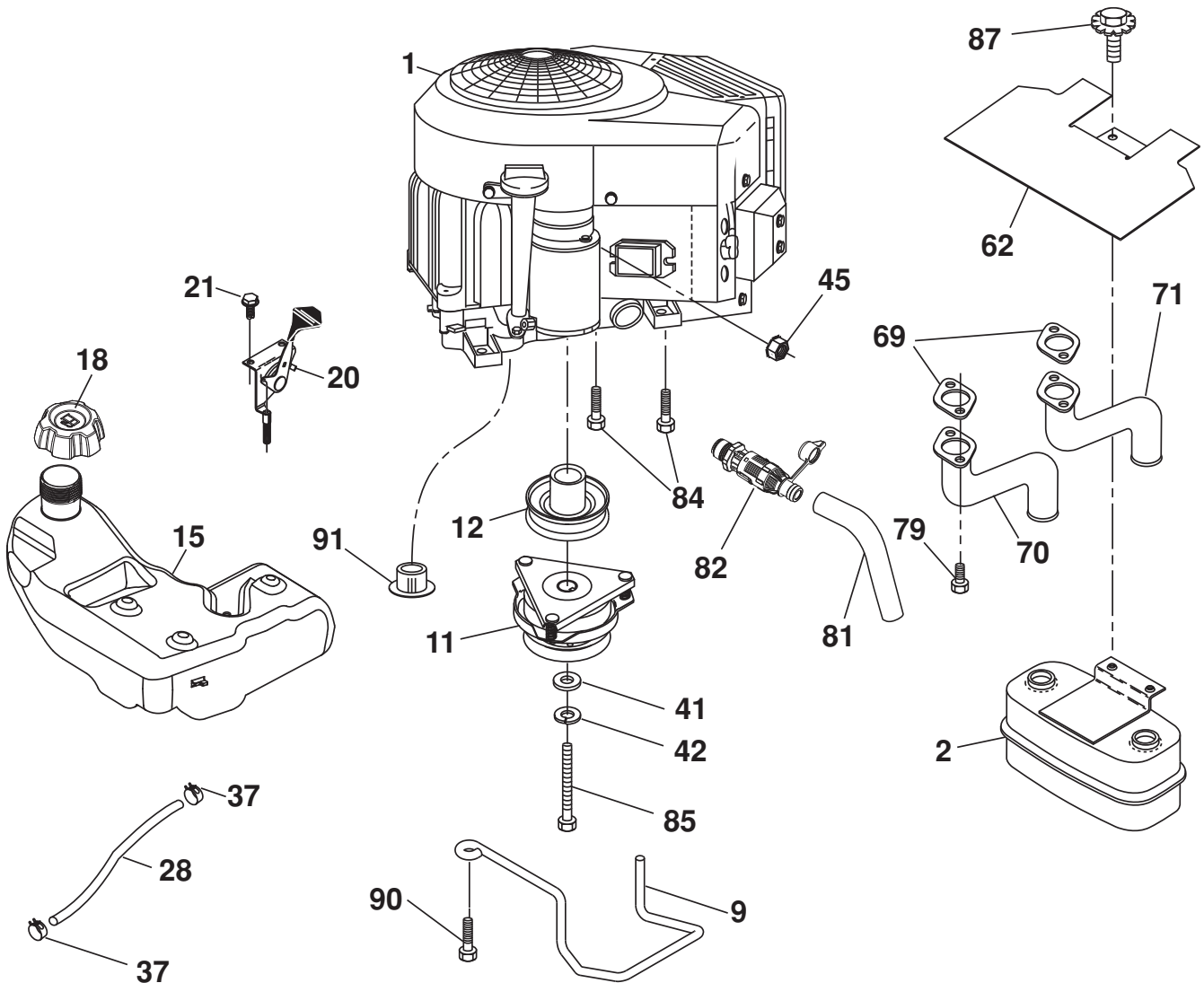

SPARK ARRESTER KIT

engine-tex_bs-2cyl_52

TRACTOR - MODEL NO. YTH24V54 (96043009301), PRODUCT NO. 960 43 00-93 ENGINE

KEY NO.	PART NO.	DESCRIPTION
1	-----	Engine Briggs Model No. 445677-1198-B1
2	532 14 97-23	Muffler
9	532 19 43-20	Keeper Belt Engine
11	532 40 00-08	Clutch Electric
12	532 40 50-97	Pulley Engine
15	532 40 00-21	Tank Fuel
18	532 43 02-17	Cap Asm
20	532 42 35-02	Control Throttle
21	532 41 63-58	Screw #10 x 0.750 BOS Thread
28	532 40 11-35	Fuel Line
29	532 13 71-80	Spark Arrester Kit
37	532 12 34-87	Clamp Hose
41	532 12 61-97	Washer 1-1/2 OD x 15/32 ID x .250
42	810 04 07-00	Washer Lock 7/16
45	873 51 04-00	Nut Keps Hex 1/4-20 unc
62	532 43 40-17	Shield Heat Muffler
69	532 16 53-91	Gasket
70	532 15 99-55	Tube Exhaust LH
71	532 16 05-89	Tube Exhaust RH
79	532 18 39-06	Screw Socket Head 5/16-18 x 1
81	532 14 84-56	Tube Drain Oil Easy
82	532 42 82-87	Drain Oil Valve
84	817 06 06-20	Screw 3/8-16 x 1-1/4
85	532 17 39-37	Bolt Hex 7/16-20 x 4 Cat. 5-1 THR.
87	532 17 18-77	Bolt 5/16-18 x 3/4
90	817 00 06-16	Screw 3/8-16 x 1
91	532 18 74-95	Bushing

NOTE: All component dimensions given in U.S. inches
1 inch = 25.4 mm

For engine service and replacement parts, call the toll free number for your engine manufacturer listed below:

Briggs & Stratton 1-800-233-3723

Engine Power Rating Information

The gross power rating for individual gas engine models is labeled in accordance with SAE (Society of Automotive Engineers) code J1940 (Small Engine Power & Torque Rating Procedure), and rating performance has been obtained and corrected in accordance with SAE J1995 (Revision 2002-05). Torque values are derived at 3060 RPM; horsepower values are derived at 3600 RPM. Actual gross engine power will be lower and is affected by, among other things, ambient operating conditions and engine-to-engine variability. Given both the wide array of products on which engines are placed and the variety of environmental issues applicable to operating the equipment, the gas engine will not develop the rated gross power when used in a given piece of power equipment (actual "on-site" or net power). This difference is due to a variety of factors including, but not limited to, accessories (air cleaner, exhaust, charging, cooling, carburetor, fuel pump, etc.), application limitations, ambient operating conditions (temperature, humidity, altitude), and engine-to-engine variability. Due to manufacturing and capacity limitations, Briggs & Stratton may substitute an engine of higher rated power for this Series engine.

TRACTOR - MODEL NO. YTH24V54 (96043009301), PRODUCT NO. 960 43 00-93
STEERING ASSEMBLY

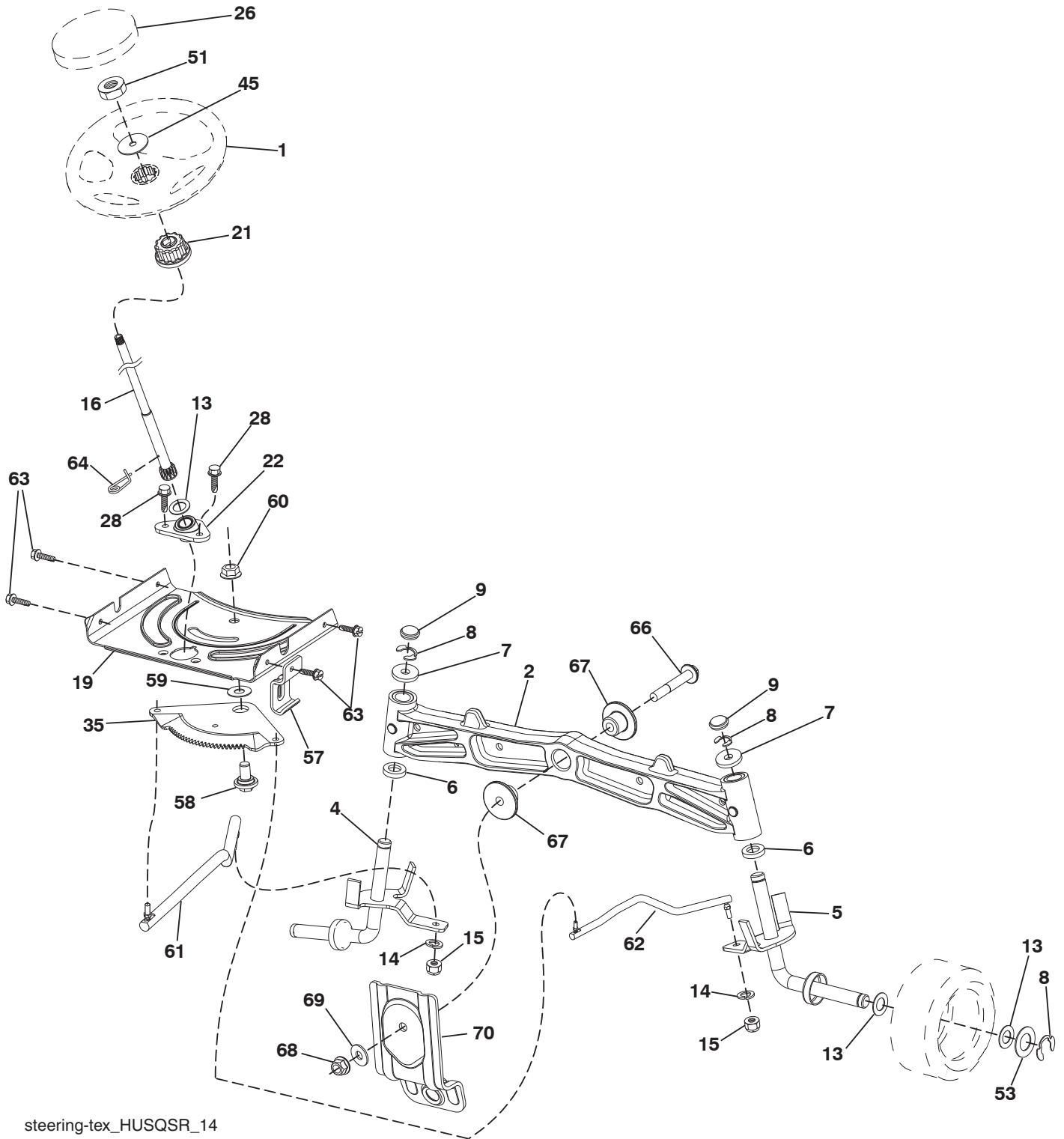

steering-tex_HUSQSR_14

**TRACTOR - MODEL NO. YTH24V54 (96043009301), PRODUCT NO. 960 43 00-93
STEERING ASSEMBLY**

KEY NO.	PART NO.	DESCRIPTION
1	532 41 64-80	Wheel, Steering
2	532 19 59-68	Axle Asm., Front
4	532 40 30-89	Spindle Asm., LH
5	532 40 30-90	Spindle Asm., RH
6	532 12 49-31	Bearing, Race Thrust Harden
7	532 12 17-48	Washer 25/32 x 1-5/8 x 16 Ga.
8	812 00 00-29	Ring, Klip #T5304-75
9	532 12 12-32	Cap, Spindle
13	532 12 17-49	Washer 25/32 x 1-1/4 x 16 Ga.
14	810 04 06-00	Washer, Lock Hvy Hlcl Spr 3/8
15	873 54 06-00	Nut, Crown Lock 3/8-24 unf
16	532 40 82-19	Shaft Steering
19	532 19 47-29	Plate Steering
21	532 18 67-37	Adapter, Wheel Steering
22	532 42 05-37	Strg. Supt. lower
26	532 41 59-87	Insert, Wheel Steering
28	817 00 06-12	Screw 3/8-16 x 3/4
35	532 19 47-32	Gear, Sector Plate
45	819 18 38-12	Washer 9/16 x 2-3/8 x 12 Ga.
51	873 94 08-00	Nut Hex Jam Toplock 1/2-20 unf
53	532 18 89-67	Washer Hardened .793x1.637x.060
57	532 19 72-46	Bracket Upstop
58	532 19 47-47	Bolt Shoulder Sector Pivot CFM
59	532 19 47-48	Washer Thrust Sector Steering
60	873 97 10-00	Nut Flange Lock 5/8-11
61	532 19 47-40	Draglink LH
62	532 19 47-41	Draglink, RH
63	817 00 05-12	Screw 5/16-18 x 3/4
64	532 19 98-49	Retainer Clip Spring Steering
66	871 02 07-48	Bolt Hex Fghd 7/16-14 x 3 Serr
67	532 19 47-37	Bushing PM Front Axle
68	873 90 07-00	Nut Lock Flange 7/16-14 Gr. 5
69	532 19 91-62	Washer 1.5 x .505 x .118
70	532 19 61-97	Bracket Deck Susp. Front

NOTE: All component dimensions given in U.S. inches
1 inch = 25.4 mm

TRACTOR - MODEL NO. YTH24V54 (96043009301), PRODUCT NO. 960 43 00-93
MOWER DECK

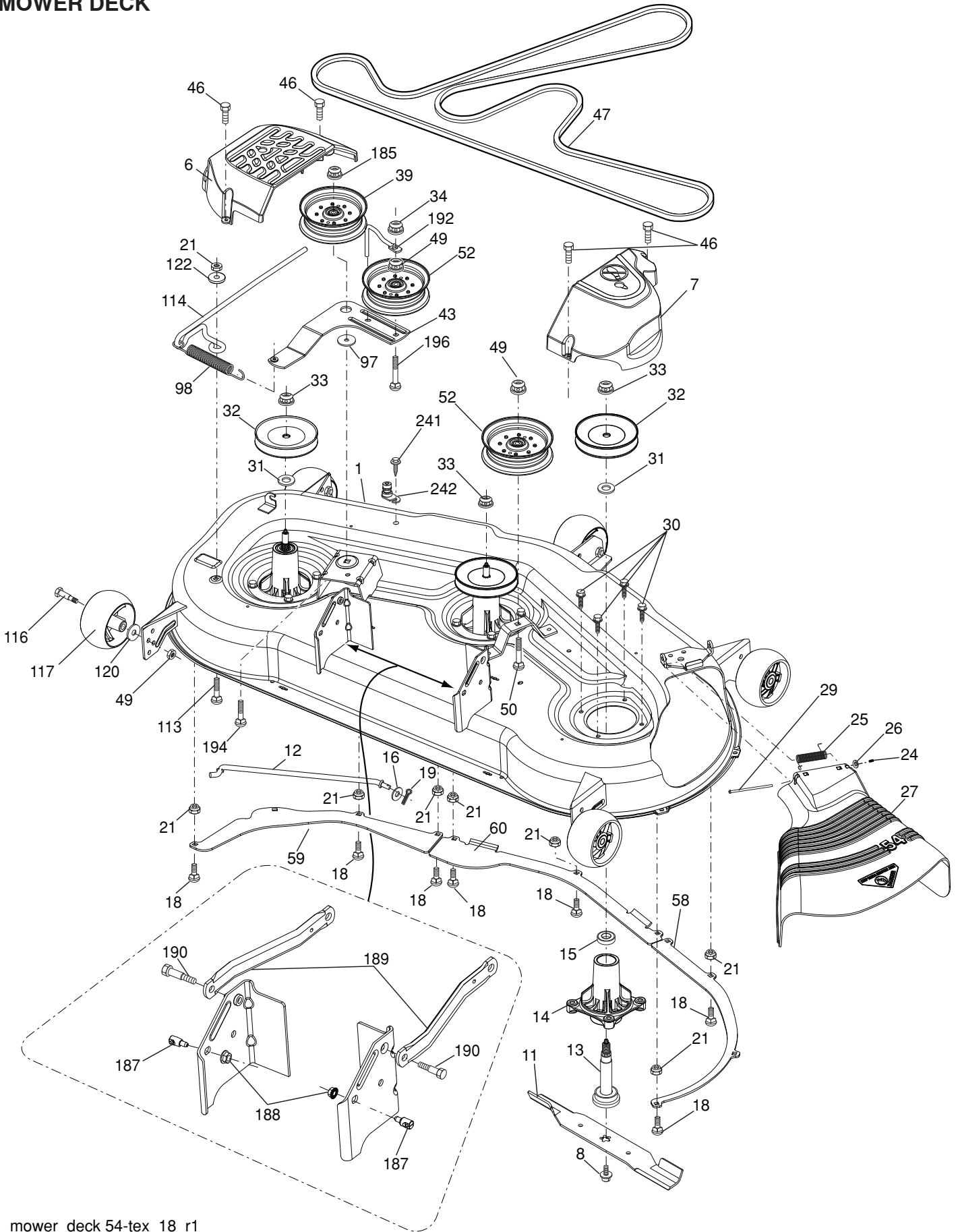

mower_deck 54-tex_18_r1

**TRACTOR - MODEL NO. YTH24V54 (96043009301), PRODUCT NO. 960 43 00-93
MOWER DECK**

KEY NO.	PART NO.	DESCRIPTION	KEY NO.	PART NO.	DESCRIPTION
1	532 40 31-25	Deck Weldment Mower	58	532 18 73-42	Baffle Right
6	532 19 60-66	Cover Mandrel LH	59	532 18 73-44	Baffle Left
7	532 19 71-81	Cover Mandrel RH	60	532 18 76-07	Baffle Center
8	532 19 30-03	Bolt 7/16 Asm. Blade	97	532 17 85-15	Washer Hardened
11	532 18 72-56	Blade Bagging	98	532 19 61-05	Spring Drive
- -	532 18 72-55	Blade Mulching	113	872 11 05-08	Bolt Rdhd Sqnk 5/16-18 x 3/4
12	532 40 48-51	Rod Anti Sway	114	532 18 75-56	Rod Tension Relief
13	532 18 72-91	Shaft Asm. w/Lower Bearing	116	532 19 34-06	Bolt, Shoulder
14	532 18 72-81	Housing, Mandrel	117	532 17 48-73	Gauge Wheel
16	819 13 13-12	Washer 3/8	120	819 13 20-12	Washer 13/32 x 1-1/4 x 12 Ga.
15	532 11 04-85	Bearing, Ball, Mandrel	122	532 18 75-57	Bushing Tension Relief
18	872 14 05-05	Bolt Carriage 5/16-18 x 5/8	185	873 90 07-00	Nut Lock Flange 7/16-14 Gr. 5
19	532 19 42-08	Pin Cotter 5/16 Bowtie	187	532 19 51-61	Stud Fastener w/"D" Anti-Rotation
21	873 68 05-00	Nut, Crownlock 5/16-18 unc	188	873 90 05-00	Nut Lock Hex Flange 5/16-18
24	532 10 53-04	Cap Sleeve	189	532 19 51-85	Arm Susp. Mower Rear
25	532 17 81-02	Spring, Torsion	190	532 19 65-39	Bolt Shoulder
26	532 11 04-52	Nut, Push	192	532 19 84-68	Keeper Belt Idler
27	532 18 89-38	Deflector Shield	194	872 14 07-16	Bolt Carr Sqnk 7/16-24 x 2
29	532 13 14-91	Rod, Hinge	196	872 14 06-20	Bolt Rdhd 3/8-16 x 2-1/2 Gr. 5
30	532 17 39-84	Screw, Thdroll Washer Head	241	532 15 29-27	Screw TT #10-32.5. 3/8 Flange
31	532 18 76-90	Washer, Spacer Mower Vented	242	532 41 55-98	Port Washout
32	532 15 35-35	Pulley, Mandrel	- -	532 18 72-92	Mandrel Asm. Service Mandrel Assembly (Includes housing, shaft assembly, and bearing only - pulley/nut/washer and blade bolt/washers not included)
33	532 40 02-34	Nut, Flg. Top Lock			
34	873 68 06-00	Nut Crownlock 3/8-16 unc			
39	532 19 73-80	Pulley, Idler, 4.50			
43	532 19 60-65	Arm, Idler			
46	532 13 77-29	Screw, Thdroll. 1/4-20 x 5/8			
47	532 19 61-03	Belt Deck Drive	- -	532 19 93-00	Replacement Mower, Complete
49	873 90 06-00	Nut, Lock Flg. 3/8-16 unc			
50	872 11 06-16	Bolt Rdhd Sqnk 3/8-16 unc x 2			
52	532 19 73-79	Pulley Idler			

NOTE: All component dimensions given in U.S. inches
1 inch = 25.4 mm

**TRACTOR - MODEL NO. YTH24V54 (96043009301), PRODUCT NO. 960 43 00-93
MOWER LIFT**

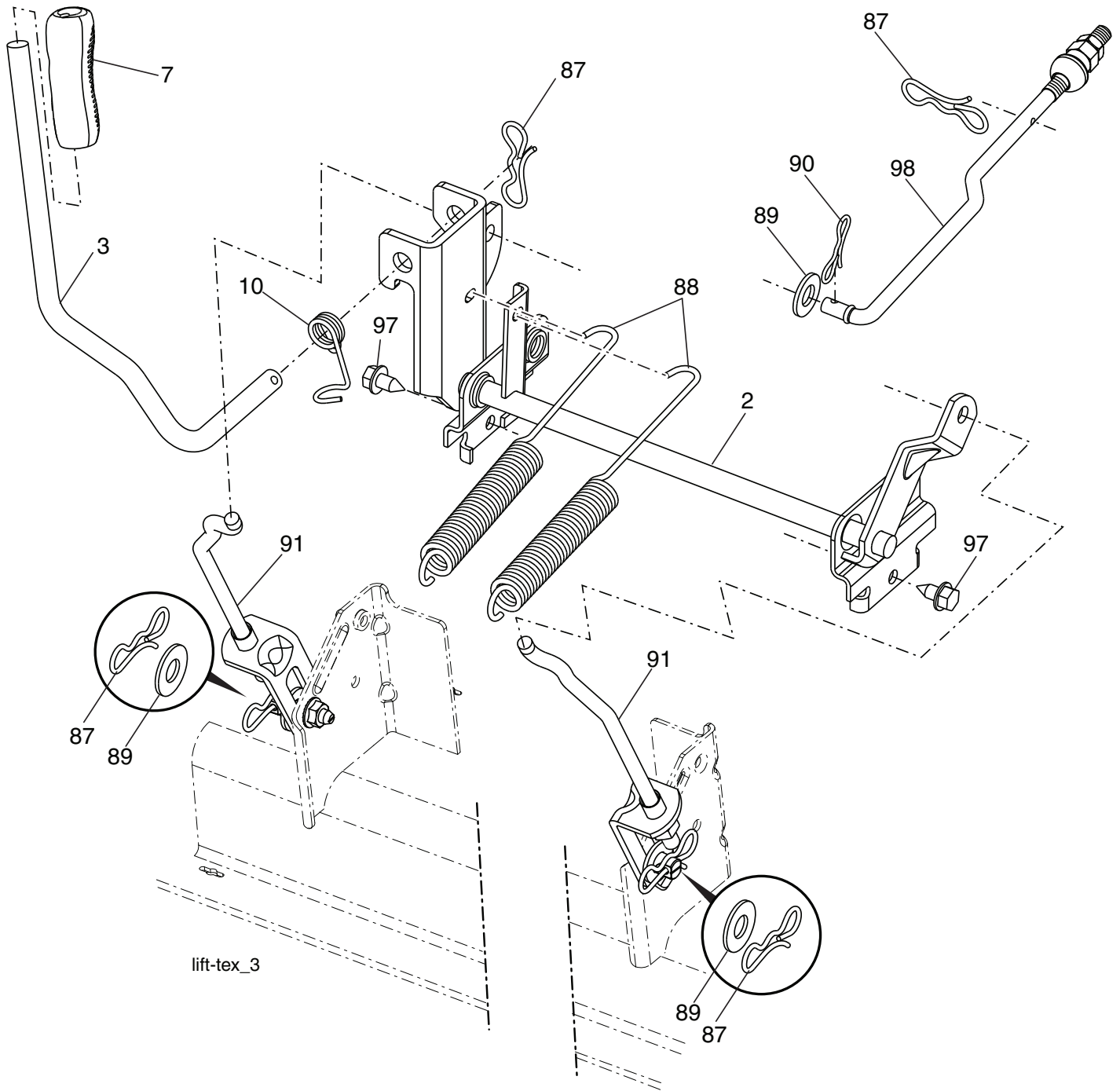

KEY NO.	PART NO.	DESCRIPTION
2	532 42 20-27	Shaft Asm., Lift
3	532 19 52-31	Lever Asm., Lift RH
7	532 41 15-55	Grip, Lever
10	532 19 63-14	Spring Torsion
87	532 19 42-09	Pin Cotter 7/16 Bow Tie Lock
88	532 41 07-10	Spring Lift Assist
89	819 19 19-12	Washer Clear Zinc

KEY NO.	PART NO.	DESCRIPTION
90	532 19 42-08	Pin Cotter 5/16 Bow Tie Lock
91	532 40 34-07	Link Lift Susp Mower Rear
97	817 00 06-12	Screw 3/8-16 x 3/4
98	532 19 52-64	Link Lift Susp. Front Mower

NOTE: All component dimensions given in U.S. inches
1 inch = 25.4 mm

**TRACTOR - MODEL NO. YTH24V54 (96043009301), PRODUCT NO. 960 43 00-93
SEAT ASSEMBLY**

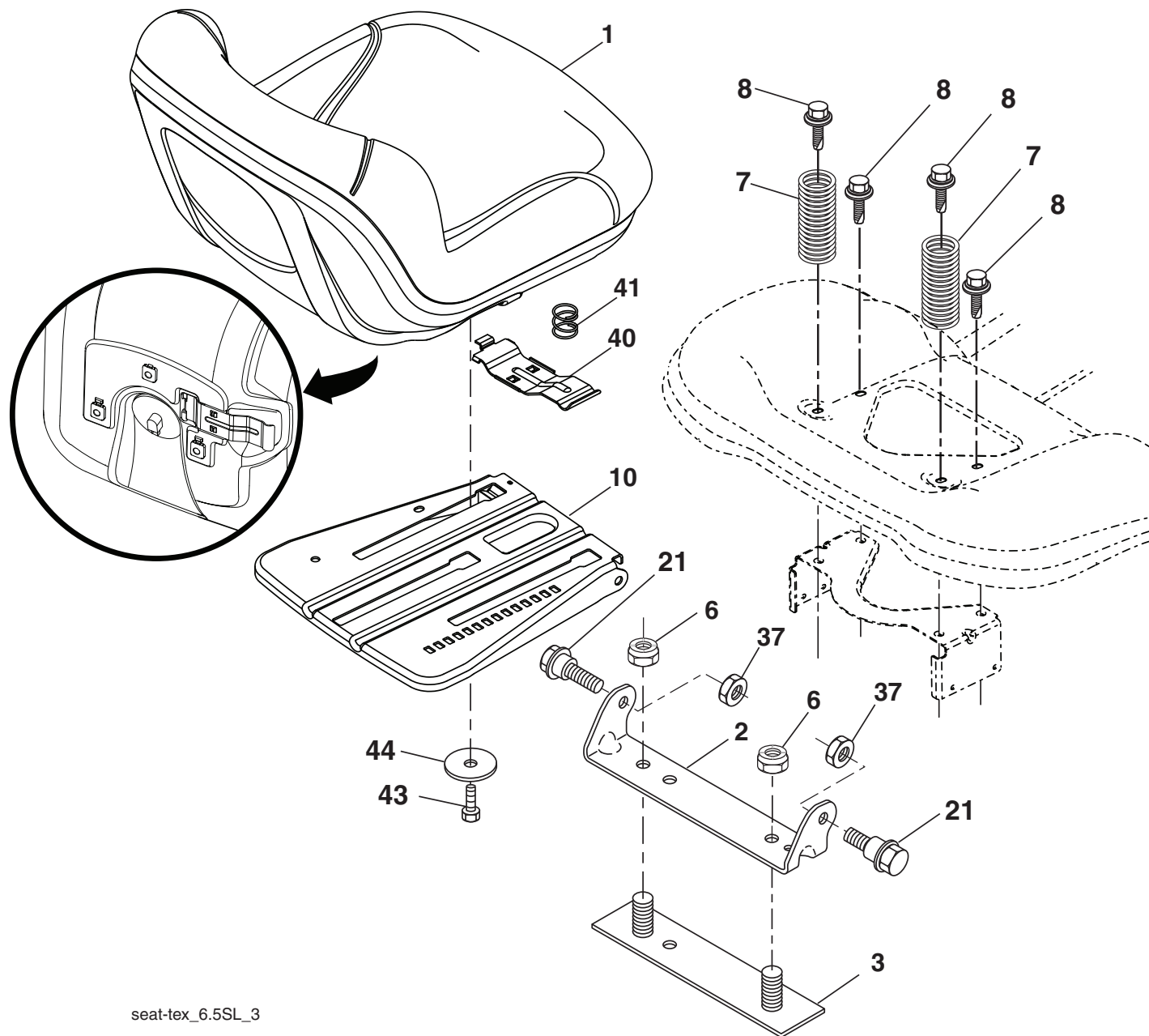

seat-tex_6.5SL_3

KEY NO.	PART NO.	DESCRIPTION
1	532 42 40-68	Seat
2	532 18 01-66	Bracket Pivot Fender
3	532 14 06-75	Strap, Asm Fender
6	873 80 06-00	Nut, Lock w/Ins. 3/8-16 unc
7	532 12 41-81	Spring, Seat Cprsn
8	532 17 18-77	Bolt 5/16-18 unc x 3/4 w/Sems
10	532 19 69-77	Pan, Seat
21	532 17 18-52	Bolt, Shoulder 5/16-18

KEY NO.	PART NO.	DESCRIPTION
37	873 80 05-00	Nut, Lock 5/16-18 unc
40	532 19 76-61	Handle Slide Seat
41	532 19 82-00	Spring Latch Seat
43	874 76 06-12	Bolt 3/8-16 x 3/4
44	819 13 38-12	Washer 13/32 x 2-3/8 x 12 Ga.

NOTE: All component dimensions given in U.S. inches
1 inch = 25.4 mm

**TRACTOR - MODEL NO. YTH24V54 (96043009301), PRODUCT NO. 960 43 00-93
DECALS**

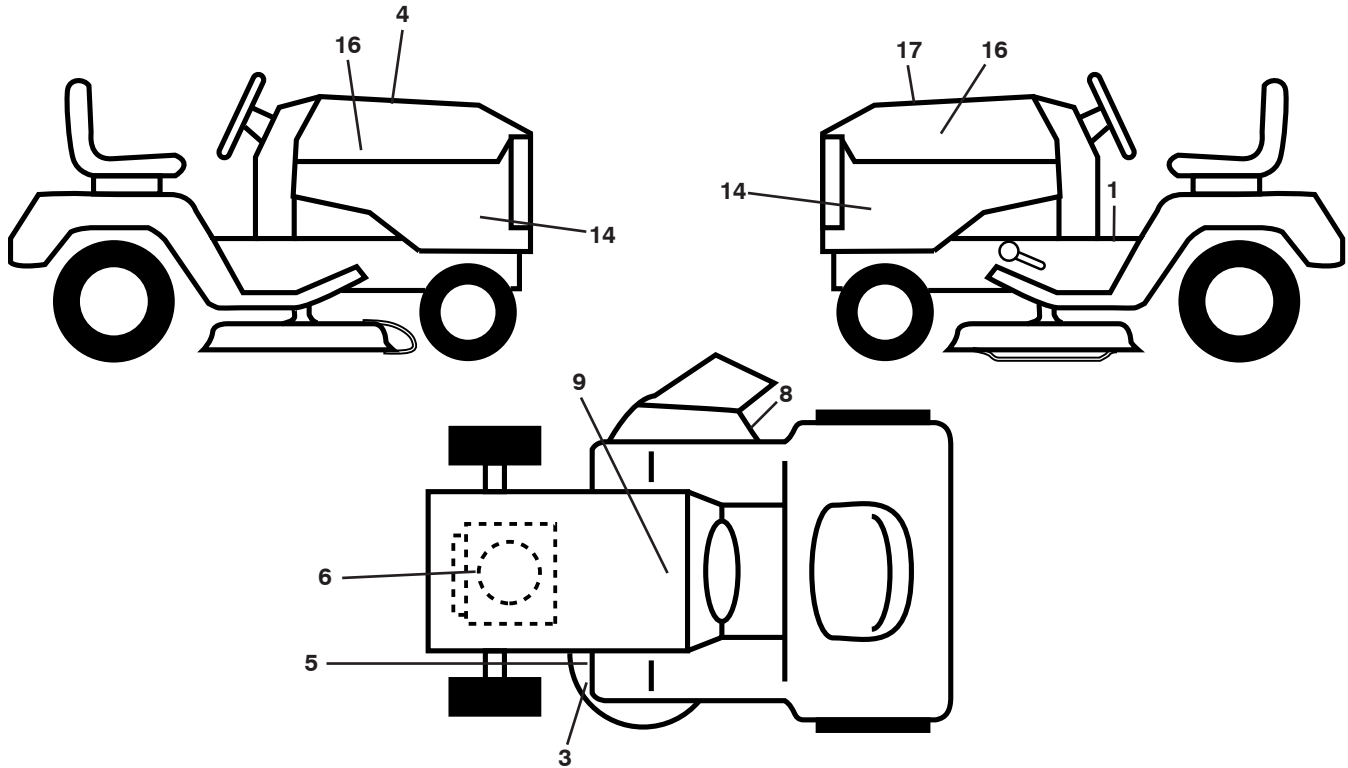

KEY NO.	PART NO.	DESCRIPTION
1	532 41 16-58	Decal, Fender Warning
3	532 17 05-63	Decal, Warning
4	532 42 38-29	Decal, Hood Cust Resp
5	532 17 84-55	Decal, Caution
6	532 42 95-62	Decal, Eng. HP
8	532 19 87-85	Decal, Mower Sch.
9	532 14 50-05	Decal, Battery Dnge/Poi
14	532 43 31-43	Decal, Panel Side

KEY NO.	PART NO.	DESCRIPTION
16	532 42 91-96	Decal, Hood Logo
17	532 43 19-60	Decal, Replacement
--	532 16 69-60	Decal, Bypass
--	532 41 08-05	Pad, Footrest, LH
--	532 41 08-06	Pad, Footrest, RH
--	532 43 62-84	Manual, Owner's (English)
--	532 43 62-85	Manual, Owner's (French)

WHEELS AND TIRES

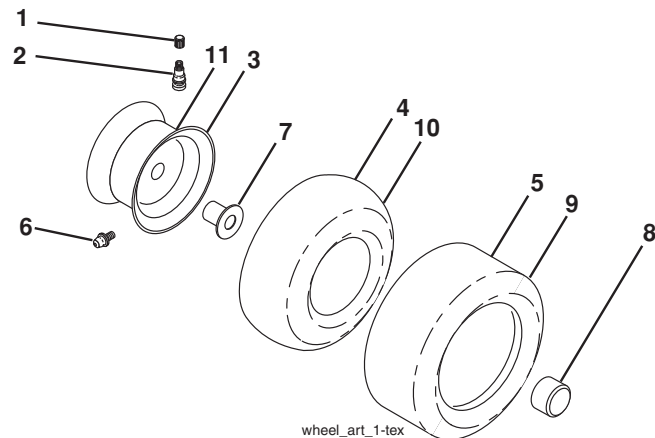

KEY NO.	PART NO.	DESCRIPTION
1	532 05 91-92	Cap, Valve, Tire
2	532 06 51-39	Stem, Valve
3	532 18 18-39	Rim Assembly, Front
4	532 00 81-34	Tube, Front (Service Item Only)
5	532 10 62-30	Tire, Front
6	532 12 49-57	Fitting, Grease (Front Wheel Only)
7	532 12 49-59	Bearing, Flange (Front Wheel Only)
8	532 17 50-39	Cap, Axle (Front Wheel Only)
9	532 13 84-68	Tire, Rear
10	532 12 49-26	Tube, Rear (Service Item Only)
11	532 13 83-37	Rim Assembly, Rear
--	532 14 43-34	Sealant, Tire (10 oz. Tube)

NOTE: All component dimensions given in U.S. inches
1 inch = 25.4 mm

SUGGESTED GUIDE FOR SIGHTING SLOPES FOR SAFE OPERATION

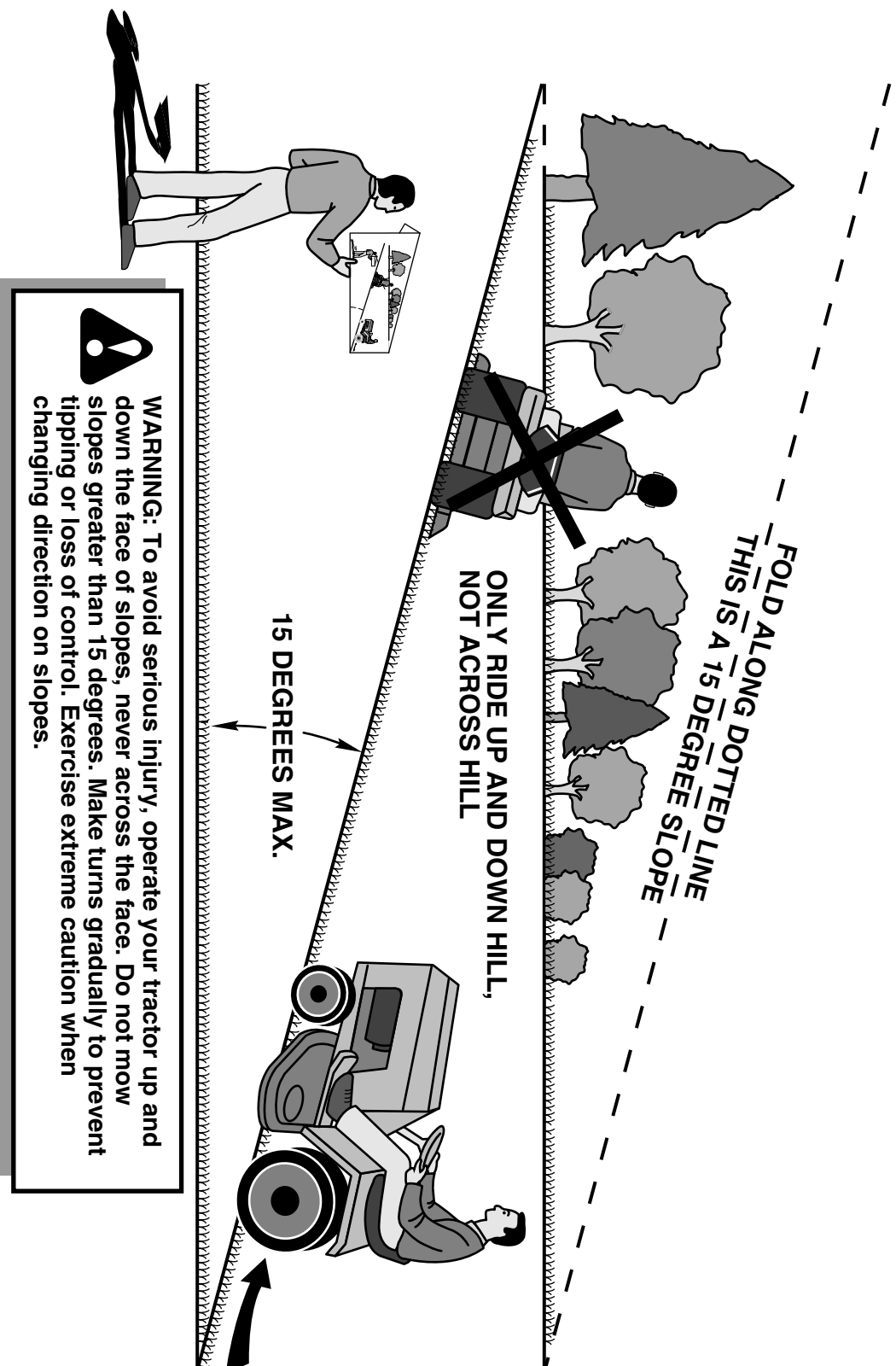

SERVICE NOTES

SERVICE NOTES

WARRANTY STATEMENT

SECTION 1: LIMITED WARRANTY

Husqvarna Forest & Garden Company ("Husqvarna") warrants Husqvarna product to be free from defects in material and workmanship from the date of purchase for the "Warranty Period" of the product as set forth below:

Lifetime Warranty (Parts and Labor): All tiller lines and trimmer shafts against breakage. Proof of purchase required.

Lifetime Warranty ("PARTS ONLY" after initial warranty expiration): Ignition coils and modules on handheld product. Proof of purchase required.

WARRANTY SCHEDULE FOR TURF CARE EQUIPMENT - Zero Turn Riders

(New warranty applies to units sold after August 1, 2005. Also applies to units factory-equipped with R.O.P.S.)

EZ Zero Turn Riders: 3 year consumer warranty or 600 hours of use (when used solely at the owner's residence.)

EZ & MZ Zero Turn Riders: 1 year commercial warranty or 600 hours of use.

IZ, LZ & BZ Zero Turn Riders: 5 year consumer warranty or 1,500 hours of use.

IZ, LZ & BZ Zero Turn Riders: 5 year commercial warranty or 1,500 hours of use.

3 Year or 1,500 Hour Commercial Use Warranty: spindles on zero turn riders, hydraulic pumps and wheel motors.

Warranty Schedule for Turf Care Walk Behind Units - W, WG & WH Zero Turn Riders - 3 year consumer and commercial warranty. New warranty applies to units sold after August 1, 2005. Also applies to units factory-equipped with R.O.P.S.

2 Year COMMERCIAL and CONSUMER Warranty: all Husqvarna ground-engaging commercial equipment.

WARRANTY SCHEDULE FOR CONSUMER TURF CARE EQUIPMENT:

2 Year Consumer Warranty: Automatic mower, all Residential Zero Turn Riders, all lawn, yard and garden tractors, all noncommercial walk behind mowers, tillers, snow blowers, electrical products and power-assist collection systems for noncommercial, nonprofessional, noninstitutional or nonincome producing use, except as herein stated. All consumer product use must have been limited to the owner's residence.

WARRANTY SCHEDULE FOR CONSUMER FOREST & GARDEN EQUIPMENT:

2 Year Consumer Warranty: all consumer chain saws, trimmers, brushcutters, clearing saws, handheld blowers, backpack blowers, hedge trimmers, and electrical products for noncommercial, nonprofessional, noninstitutional or nonincome producing use, except as herein stated. All consumer product use must have been limited to the owner's residence.

2 Year or 2,000 Hour Powertrain & 1 Year or 1,000 Hour Body Warranty: Husqvarna Utility Vehicles.

1 Year Warranty: Power cutters, stump grinder, pole pruners and pole saws for non-commercial, non-professional, noninstitutional, non-municipality or non-income producing use. All 300 series trimmers, brushcutters, clearing saws, hovering trimmers, stick edgers, backpack blowers, hand held blowers, hedge trimmers, power-assist collection systems for commercial, institutional, professional or income producing purposes or use.

1 Year Conditional Component Warranty: Chain saw crankshafts for commercial/professional use (parts and labor). Saw must be operated with Husqvarna XP 2 cycle oil.

90 Day Commercial Warranty: Automatic mower, chain saws, 100 series trimmers, power cutters, stump grinders, pole saws, pole pruners, snow throwers, model series 580 & 600 walk-behind mowers, or any Husqvarna product used for commercial, institutional, professional, municipality or income producing purposes or use except as otherwise provided herein.

Batteries: 1 year prorated limited warranty with 100% replacement during the first 6 months.

Rental Warranty: 90 days on all applicable professional equipment reference warranty time period charts located in the back of the Retailer Warranty Policy & Procedure Manual.

Husqvarna Safety Apparel carries a 90-day warranty from the date of the customer's original purchase for defects in material and workmanship. Normal wear, tear or abuse is not covered under warranty. Product must be returned to Charlotte with a warranty claim form. All care and maintenance instructions must be followed as stated by the manufacturer on the care label. The fit of the protective apparel/boot is not covered under warranty.

30 Day Warranty: Replacement parts, accessories including bars and chains, tools and display items. Emission control system components necessary to comply with CARB-TIER II and EPA regulations, except for those components which are part of engine systems manufactured by third part engine manufacturers for which the purchaser has received a separate warranty with product at time of purchase.

SECTION 2: HUSQVARNA'S OBLIGATIONS UNDER THE WARRANTY

Husqvarna will repair or replace defective components without charge for parts or labor if a component fails because of a defect in material or workmanship during the warranty period.

SECTION 3: ITEMS NOT COVERED BY THIS WARRANTY

The following items are not covered by this warranty:

- (1) Normal customer maintenance items which become worn through normal regular use, including, but not limited to, belts, blades, blade adapters, bulbs, clutches, clutch drums, filters, guide bars, lubricants, rewind springs, saw chain, spark plugs,

starter ropes and tiller lines;

- (2) Natural discoloration of material due to ultraviolet light;
- (3) Engine and drive systems not manufactured by Husqvarna; these items are covered by the respective manufacturer's warranty as provided in writing with the product information supplied at the time of purchase; all claims must be sent to the appropriate manufacturer;

(4) Lawn and garden attachments are covered by a third party which gives a warranty, all claims for warranty should be sent to the manufacturer.

(5) Commercial or consumer mowing decks with sand abrasion damage.

(6) Emission Control System components necessary to comply with CARB-TIER II and EPA regulations which are manufactured by third party engine manufacturer.

SECTION 4: EXCEPTIONS AND LIMITATIONS

This warranty shall be inapplicable to defects resulting from the following:

- (1) Accident, abuse, misuse, negligence and neglect, including state fuel, dirt, abrasives, moisture, rust, corrosion, or any adverse reaction due to incorrect storage or use habits;

(2) Failure to operate or maintain the unit in accordance with the Owner's/Operator's manual or instruction sheet furnished by Husqvarna;

(3) Alterations or modifications that change the intended use of the product or affects the product's performance, operation, safety, or durability, or causes the product to fail to comply with any applicable laws; or

(4) Additional damage to parts or components due to continued use occurring after any of the above.

REPAIR OR REPLACEMENT AS PROVIDED UNDER THIS WARRANTY IS THE EXCLUSIVE REMEDY OF THE PURCHASER. HUSQVARNA SHALL NOT BE LIABLE FOR ANY INCIDENTAL OR CONSEQUENTIAL DAMAGES FOR BREACH OF ANY EXPRESS OR IMPLIED WARRANTY ON THESE PRODUCTS EXCEPT TO THE EXTENT PROHIBITED BY APPLICABLE LAW. ANY IMPLIED WARRANTY OF MERCHANTABILITY OR FITNESS FOR A PARTICULAR PURPOSE ON THESE PRODUCTS IS LIMITED IN DURATION TO THE WARRANTY PERIOD AS DEFINED IN THE LIMITED WARRANTY STATEMENT. HUSQVARNA RESERVES THE RIGHT TO CHANGE OR IMPROVE THE DESIGN OF THE PRODUCT WITHOUT NOTICE, AND DOES NOT ASSUME OBLIGATION TO UPDATE PREVIOUSLY MANUFACTURED PRODUCTS.

Some states do not allow the exclusion of incidental or consequential damages, or limitations on how long an implied warranty lasts, so the above limitations or exclusions may not apply to you. This warranty gives you specific legal rights, and you may also have other rights which vary from state to state.

SECTION 5: CUSTOMER RESPONSIBILITIES

The product must exhibit reasonable care, maintenance, operation, storage and general upkeep as written in the maintenance section of the Owner's/Operator's manual. Should an operational problem or failure occur, the product should not be used, but delivered as is to an authorized Husqvarna retailer for evaluation. Proof of purchase, as explained in section 6, rests solely with the customer.

SECTION 6: PROCEDURE TO OBTAIN WARRANTY CONSIDERATION

It is the Owner's and Retailer's responsibility to make certain that the Warranty Registration Card is properly filled out and mailed to Husqvarna Forest & Garden Company. This card should be mailed within ten (10) days from the date of purchase in order to confirm the warranty and to facilitate post-sale service.

Proof of purchase must be presented to the authorized Husqvarna retailer in order to obtain warranty service. This proof must include date purchased, model number, serial number, and complete name and address of the selling retailer.

To obtain the benefit of this warranty, the product believed to be defective must be delivered to an authorized Husqvarna retailer in a timely manner, no later than thirty (30) days from date of the operational problem or failure. The product must be delivered at the owner's expense. Downtime, pick-up and delivery charges are not covered by this warranty. An authorized Husqvarna retailer can be normally located through the "Yellow Pages" of the local telephone directory or by calling 1-800-HUSKY62 for a retailer in your area.

HUSQVARNA

9335 Harris Corners Parkway

Charlotte, NC 28269

2008